



Tested & Complies with



Tested & Complies with



Meets Specifications



Tested & Complies with

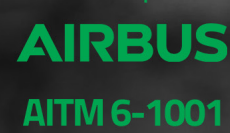

LED UV-A LAMPS

2023

relinc.com



Glo-Black LED UV-A Lamps

C4 MAGNUM	5	REL STAR TESTING PANEL	75
C4 MAGNUM-GO	15	FPI MOBILE TESTING KIT	77
LIQUID MAGNUM	21	SNAPSHOT-UV	79
C4 NOMAD	29	BOLT ON POWER	81
C4 NOMAD-GO	39	REL PRODUCT INTEGRATION	83
NOMAD-ASCENT	45	ACCESSORIES	85
PROFUSION	51		
PROFUSION XW	63		

LED UV-A LAMPS

Complex Challenges. Convenient Solutions.



**MADE IN
THE USA**



TOUGH.



REL has created the most robust UV-A lamps available to the world NDT market.

We originally developed our LED UV-A inspection lamps as an enhancement to our non-destructive testing equipment. We couldn't find another lamp that was up to the demanding use case of 'REL normal operating conditions.' These conditions are modeled after reality, where products get dropped, kicked, and run over. The lamp product MUST work during and after these sudden and realistic events. In fact, we guarantee it will. When you buy our product, we warranty ANY damage you think should be covered, PERIOD. The result is a bulletproof, versatile, easy-to-use lamp that is sensitive enough for the clean room, and strong enough to withstand continuous use in the harshest industrial environments.

REL inspection lamps are designed for all power and intensity prerequisites of Fluorescent Penetrant Inspection (FPI), Magnetic Particle Inspection (MPI), and a plethora of leak detection applications as set forth in the aerospace, automotive, defense, energy, and medical industries. Each lamp utilizes safe, high yield, LED UV-A technology, and contains a high flux LED UV-A emitter with a built-in electrostatic discharge circuit, robustly coupled to a passively cooled IP67 machined military-grade aluminum housing to enable the light to perform to specification and your expectations!

C4 MAGNUM LED UV-A LAMP

Tested & Complies with



Meets Specifications



Tested & Complies with

Rolls-Royce
RRES 90061
REQUIREMENTS

Tested & Complies with

AIRBUS
AITM 6-1001

NSN: 5980-01-671-7903

Directions For Use:

1. Remove from tool control solution.
2. Drop
3. Kick
4. Use

*Note: Steps 2-4 can be performed in any order!





UV light
hazard.
Avoid looking
directly at light.

WALSH INDUST



C4 MAGNUM & MAGNUM-GO LED UV-A CHARACTERISTICS

<i>Performance Attributes</i>	<i>Parameters</i>
Maximum Irradiance (at 15 in/38cm)	5000 $\mu\text{W}/\text{cm}^2$
Peak Wavelength	365 \pm 5 nm
Irradiance at Peak Wavelength (at 15 in)	> 200 $\mu\text{W}/\text{cm}^2$
Typical Irradiated Area (profile at 15 in)	Circular Spot 10" Diameter
	> 1000 $\mu\text{W cm}^2$ (347-382 nm)
Emission Spectrum	
Full Width at Half Maximum (FWHM)	\leq 15 nm
Longest Wavelength at Half Max (LWHM)	\leq 377 nm
Full width at 10% Maximum	\leq 30 nm (\pm 15)
Excitation Irradiance (347-382 nm)	> 2500 $\mu\text{W}/\text{cm}^2$
Wavelength Drift (at 70° F ambient)	\leq 3 nm
Working Distances	
	ASTM E3022 Minimum WD \leq 5 in
	RRES 90061 Minimum WD = 12 in
	Maximum WD = 23"
Typical Visible Emission	
	ASTM E3022 range (400-760 nm) \leq 2 ft candles

<i>Physical Attributes</i>	<i>Parameters</i>
Operating Environment	32 - 120° F
Maximum Housing Temperature (at 70° F ambient)	116° F
Lamp Cord Length	10 ft (Standard)
Power Supply Cord Length	6 ft
Weight	1.7 lb
Power in	100-240V AC / 50 - 60Hz < 1.2A
Specification Compliance	ASTM E3022, RRES 90061, ISO 3059, Airbus AITM 6-1001

Emission Spectrum measured at Stabilization Temperature

10 inch diameter spot size
1000 $\mu\text{W}/\text{cm}^2$ at 15 inches away

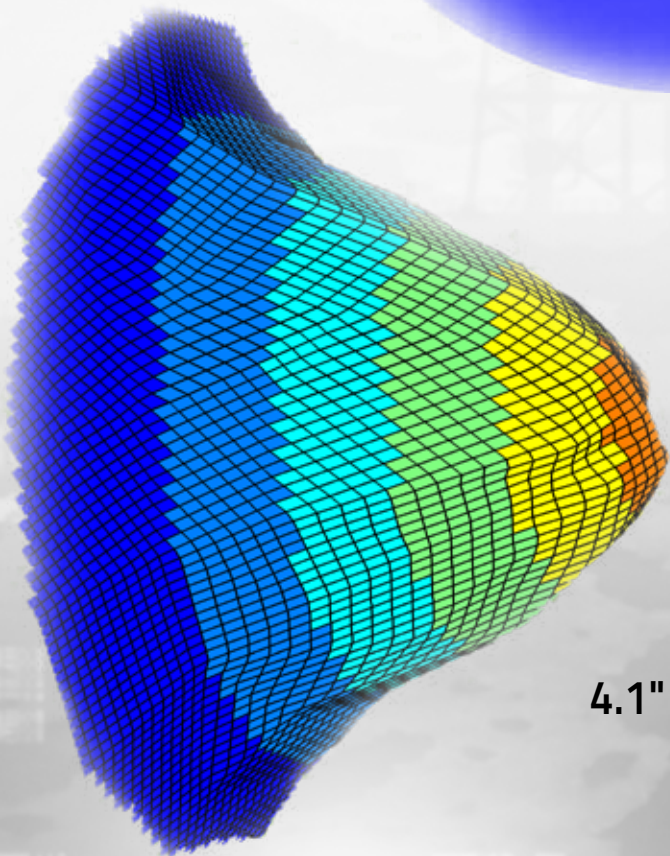
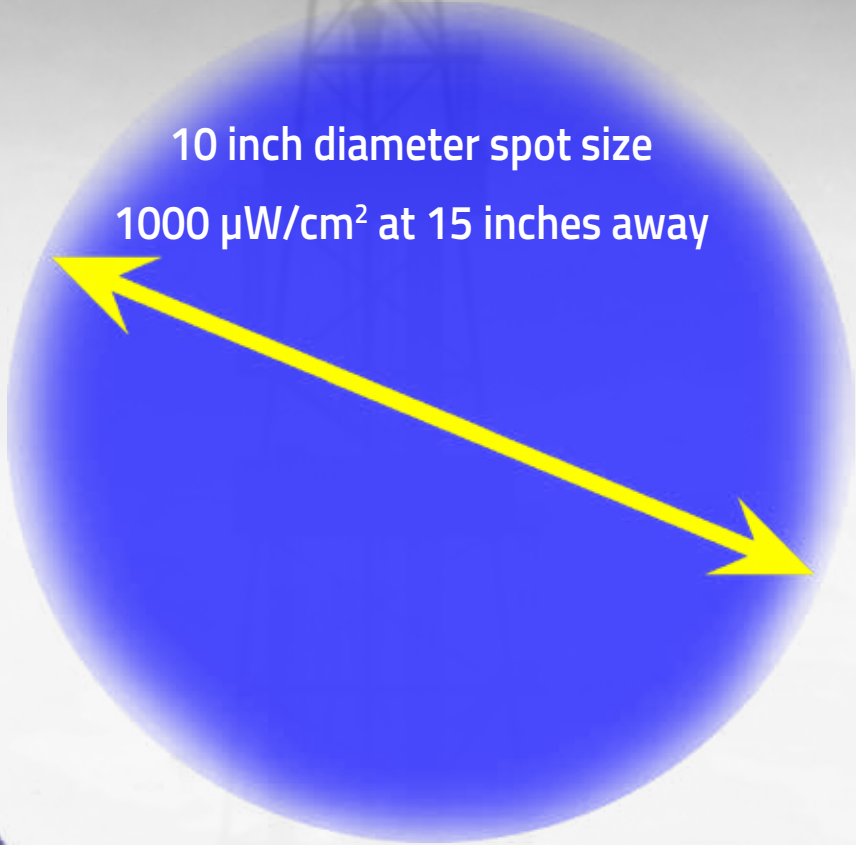
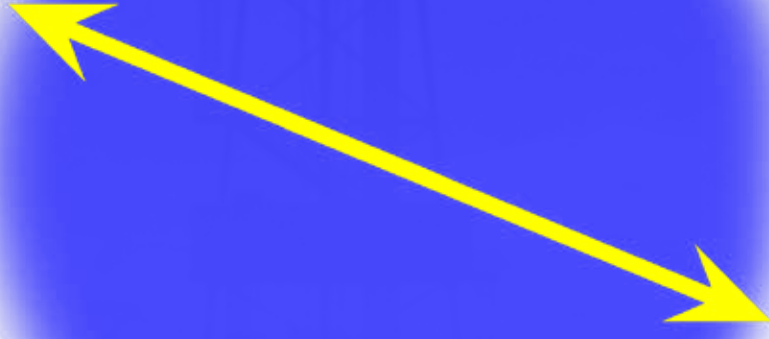

4.1"

7.6"

REL's C4 Magnum corded inspection lamps utilizes the latest UV-A LED technology for non-destructive testing.



C4 MAGNUM

The C4 Magnum contains a single high flux LED UV emitter that has a built in static-electric discharge circuit to allow the light to perform in all environments regardless of ambient conditions. Designed for Fluorescent Penetrant Inspection (FPI) and Magnetic Particle Inspection (MPI), the C4 Magnum provides a 10-inch diameter of UV-A intensity above $1000 \mu\text{W}/\text{cm}^2$ at 15 inches. The integral filter in the C4 Magnum limits the visible light to 20 lux at 15 inches and 5 lux at 36 inches. Each lamp is sealed and cooled with an engineered finned housing manufactured from a military grade aluminum. The IP67 rated housing allows the lamp to perform in all environments regardless of ambient conditions. The C4 Magnum will survive the toughest, wettest, and most severe work environments on the planet!

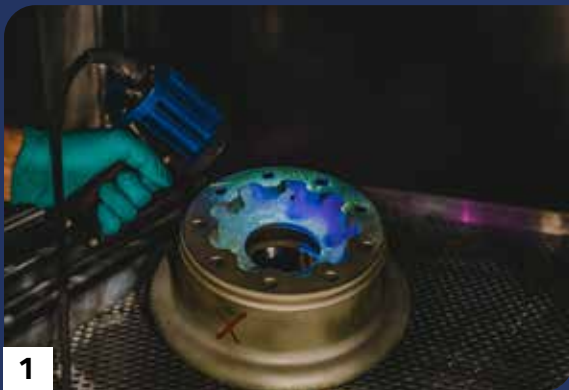

1. C4 Magnum shown in use on REL's human-driven Model I2C FPI line.
2. Bolt on Power Cord for Magnum
3. C4 Magnum IP67 rated allows performance in all environments regardless of ambient conditions.
4. C4 Magnum run over by a 16,500 lb forklift!



C4 Magnum & C4 Magnum-GO Certifications & Compliances

- TESTED & COMPLIES with ASTM E3022 STANDARD
- TESTED & COMPLIES with ROLLS-ROYCE RRES 90061
- AIRBUS AITM 6-1001
- ISO 3059
- IP67 RATED - DUST SEALED & WATERPROOFED
- 2 YEAR WARRANTY GUARANTEE
- SERIALIZED CERTIFICATE of CONFORMANCE

C4 Magnum & C4 Magnum-GO Features and Benefits

- High output UV-A LED emitters with white light (Magnum-GO) emitter for darker inspection environments
- NSN: 5980-01-671-7903 (UV-2000)
- Tested to work as hard as you do
- Engineered fin housing allows for maximum heat transfer in the harshest environments.
- Easy to use controls with clear indicators for lamp on/off operation
- Built-in static-electric discharge unit safety feature
- AC Power: 120/240V
- Individual lamp dimensions: 7.6" H x 3.0" W x 4.1" D
- Individual lamp weight: 1.7 lbs.
- Refurbishable
- Bolt on Power Cord

C4 MAGNUM: 3 WAYS TO BUY

UV-2000	Kit Includes
 The UV-2000 kit includes a blue and black handheld UV-A lamp, a black carrying case, a power supply unit, a power cord, and a pair of safety glasses.	<ul style="list-style-type: none">▪ Glo-Black C4 Magnum LED UV-A Lamp▪ Bolt on Power Cord for Magnum▪ 120/240V, 60W Power Supply▪ Tool control system▪ Safety glasses▪ NSN: 5980-01-671-7903
UV-2000NC	Kit Includes
 The UV-2000NC kit includes a blue and black handheld UV-A lamp, a power supply unit, a power cord, and a pair of safety glasses.	<ul style="list-style-type: none">▪ Glo-Black C4 Magnum LED UV-A Lamp▪ Bolt on Power Cord for Magnum▪ 120/240V, 60W Power Supply▪ Safety glasses
UV-2000LM	Kit Includes
 The UV-2000LM kit includes a blue and black handheld UV-A lamp, a power supply unit, a power cord, and a pair of safety glasses.	<ul style="list-style-type: none">▪ Glo-Black C4 Magnum LED UV-A Lamp, Legacy Model▪ 10' DC Extension Power Cord▪ 25W Wall Mounted Power Supply▪ Safety glasses

C4 MAGNUM ACCESSORIES

Part #	Description
UV-1000	Bench Adapter/Lamp Holder
UV-1020	Tool control system for Magnum Lamps
UV-1100	Mounting Arm
UV-2007	10' DC Extension Power Cord
UV-2014	Bolt on Power Cord for Magnum
UV-2016	Domer & Ding Ring
UV-2023	120/240V, 60W Power Supply
UV-7000	Spray Can Fixture
UV-7100	25W Wall Mount Power Supply
UV-7400	Snapshot-UV (GoPro™ HERO9 camera lamp mounted)

ACCESSORY HIGHLIGHT

BOLT ON POWER

A power cord that matches the toughness of our LED UV-A Lamps.



Abrasion
Resistant



Durable



Prevent
Breakage



Superior
Strength

C4 Magnum shown with
Bolt on Power Cord for Magnum (UV-2014)

C4 MAGNUM-GO

LED UV-A LAMP + White Light

Tested & Complies with



ASTM E3022
STANDARD

Meets Specifications



ISO 3059

Tested & Complies with

Rolls-Royce
RRES 90061
REQUIREMENTS

Tested & Complies with

AIRBUS
AITM 6-1001

Directions For Use:

1. Remove from tool control solution.
2. Drop
3. Kick
4. Use

*Note: Steps 2-4 can be performed in any order!





UV light
hazard.
Avoid looking
directly at light.

WATTS INDUST



The REL C4 Magnum-GO (Gas and Oil) corded LED UV-A Lamp integrates both UV-A and white light emitters for critical versatility in darker inspection environments.



C4 MAGNUM-GO

The C4 Magnum-GO is designed for all intensity requirements of Fluorescent Penetrant Inspection (FPI) and Magnetic Particle Inspection (MPI). REL's C4 Magnum-GO inspection lamps contain high flux UV-A and white light LED emitters with built-in static-electric discharge circuits. The C4 Magnum-GO provides a 10-inch diameter of UV-A intensity $>1000 \mu\text{W}/\text{cm}^2$ at 15 inches. The integral filter in the UV-A emitter limits the visible light to 20 lux (1.86 foot-candles) at 15 inches and 5 lux (0.47 foot-candles) at 36 inches. The LED white light provides an intensity > 700 -foot candles at 15 inches. The lamp's electrical components are IP67 sealed and passively cooled within an engineered finned housing manufactured from military-grade aluminum. The lamp performs in all environments regardless of ambient conditions. The C4 Magnum-GO LED UV-A with white light will survive the toughest, wettest, and most severe work environments on the planet!



1. C4 Magnum-GO in use.
2. C4 Magnum-GO front shown with both LED UV-A and white light.
3. C4 Magnum-GO run over by a 16,500 lb forklift! And it still works!
4. The IP67 rating allows performance in all environments.

C4 MAGNUM-GO: 3 WAYS TO BUY

UV-3000	Kit Includes
 The UV-3000 kit includes a blue and black handheld UV-A lamp, a black carrying case, a power supply unit, a power cord, and safety glasses.	<ul style="list-style-type: none">▪ Glo-Black C4 Magnum-GO LED UV-A Lamp▪ Bolt on Power Cord for Magnum-GO▪ 120/240V, 60W Power Supply▪ Tool control system▪ Safety glasses
UV-3000NC	Kit Includes
 The UV-3000NC kit includes a blue and black handheld UV-A lamp, a power supply unit, a power cord, and safety glasses. The tool control system is not included.	<ul style="list-style-type: none">▪ Glo-Black C4 Magnum-GO LED UV-A Lamp (Tool control system not included)▪ Bolt on Power Cord for Magnum-GO▪ 120/240V, 60W Power Supply▪ Safety glasses
UV-3000LM	Kit Includes
 The UV-3000LM kit includes a blue and black handheld UV-A lamp, a wall-mounted power supply, a 10-foot DC extension power cord, and safety glasses.	<ul style="list-style-type: none">▪ Glo-Black C4 Magnum-GO LED UV-A Lamp, Legacy Model▪ 10' DC Extension Power Cord▪ 25W Wall Mounted Power Supply▪ Safety glasses

C4 MAGNUM-GO ACCESSORIES

Part #	Description
UV-1000	Bench Adapter/Lamp Holder
UV-1020	Tool control system for Magnum Lamps
UV-1100	Mounting Arm
UV-2007	10' DC Extension Power Cord
UV-2015	Bolt on Power Cord for Magnum-GO
UV-2016	Domer & Ding Ring
UV-2023	120/240V, 60W Power Supply
UV-7000	Spray Can Fixture
UV-7100	25W Wall Mount Power Supply
UV-7400	Snapshot-UV (GoPro™ HERO9 camera lamp mounted)

ACCESSORY HIGHLIGHT

BOLT ON POWER

A power cord that matches the toughness of our LED UV-A Lamps.



Abrasion Resistant



Durable



Prevent Breakage



Superior Strength



C4 Magnum-GO shown with Bolt on Power Cord for Magnum-GO (UV-2015)

LIQUID MAGNUM LED UV-A LAMP

Tested & Complies with
Rolls-Royce
RRES 90061
REQUIREMENTS

Meets Specifications



ISO 3059





Certified
★ ★ ★
IP67 Rated
★ ★ ★
APPROVED

LIQUID MAGNUM LED UV-A CHARACTERISTICS

<i>Performance Attributes</i>	<i>Parameters</i>
Peak Wavelength	365 ± 5 nm
Emission Spectrum	
Full Width at Half Maximum (FWHM)	≤ 15 nm
Longest Wavelength at Half Max (LWHM)	≤ 377 nm
Full width at 10% Maximum	≤ 30 nm
Wavelength Drift (at 70° F ambient)	≤ 3 nm
Typical Visible Emission	
(390 nm 800 nm)	≤ 20 lux

<i>Physical Attributes</i>	<i>Parameters</i>
Operating Environment	32 - 100° F
Maximum Housing Temperature (at 70° F ambient)	122 ° F
Lamp Cord Length	10 ft Standard
Power Supply Cord Length	≈ 6 ft
Weight	1.8 lb
Power in	100-240V AC / 50 - 60Hz < 1.2A
Specification Compliance	ISO 3059, RRES 90061, Airbus AITM6-1001

Emission Spectrum measured at Stabilization Temperature

1200 $\mu\text{W}/\text{cm}^2$ at 8 inches
 4 inch diameter above 1000 $\mu\text{W}/\text{cm}^2$
 7 inch diameter over 500 $\mu\text{W}/\text{cm}^2$

@ 4 inch distance white light is less than 2 foot candles
 @ 4 inch distance there is a 5 inch diameter above 1000 $\mu\text{W}/\text{cm}^2$
 @ 4 inch distance the maximum intensity is 4600 $\mu\text{W}/\text{cm}^2$

@ 7 inch distance white light is less than 1 foot candle
 @ 7 inch distance there is a 4 inch diameter above 1000 $\mu\text{W}/\text{cm}^2$
 @ 7 inch distance the maximum intensity is 1700 $\mu\text{W}/\text{cm}^2$

@ 9 inch distance white light is less than 1 foot candle
 @ 9 inch distance there is a 1 inch diameter above 1000 $\mu\text{W}/\text{cm}^2$

Use ergonomic elegance to solve the challenges of inspecting complex part geometries with our Liquid Magnum.



Max Intensity
= $4600 \mu\text{W}/\text{cm}^2$

> $1000 \mu\text{W}/\text{cm}^2$ at
4 inches away

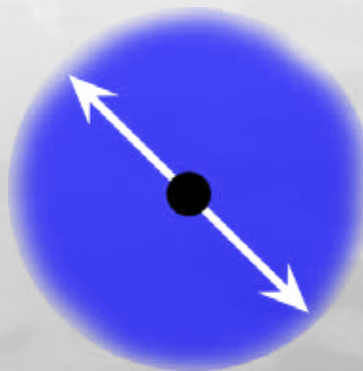

5 inches

> $1000 \mu\text{W}/\text{cm}^2$ at
7 inches away

Max Intensity
= $1700 \mu\text{W}/\text{cm}^2$

> $1000 \mu\text{W}/\text{cm}^2$ at
9 inches away

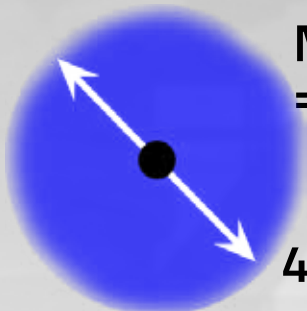

4 inches



1 inch

LIQUID MAGNUM: HOW TO BUY

UV-2100	Kit Includes
	<ul style="list-style-type: none"> ▪ Glo-Black Liquid Magnum LED UV-A Lamp ▪ 2-Meter Light Guide ▪ Bolt on Power Cord for Magnum ▪ 120/240V, 60W Power Supply ▪ Swivel Mount Lamp Holder ▪ Tool control system ▪ Safety glasses

LIQUID MAGNUM ACCESSORIES

Part #	Description
UV-1020	Tool control system for Magnum Lamps
UV-1100	Mounting Arm
UV-2007	10' DC Extension Power Cord
UV-2014	Bolt on Power Cord for Magnum Lamps
UV-2023	120/240V, 60W Power Supply
UV-2120	2-Meter Light Guide
UV-2200	Liquid Nomad LED UV-A Lamp (battery powered)
UV-7100	25W Wall Mount Power Supply

LIQUID MAGNUM

The 2-meter length of the liquid light guide allows for the inspection of depressions in surface geometries with high depth-to-diameter ratios, while maintaining fingertip control of the 365nm LED UV-A lamp.

These lamps were developed to address operator safety and the rigorous precision demands during the inspection of complex part geometries encountered in FPI and MPI inspections. Operator fatigue with the risk of carpal tunnel injuries can happen in a repetitive motion environment with non-natural wrist flexure. Utilizing a Liquid lamp limits wrist forces to less than 2oz. This allows the inspector to manipulate the powerful photon stream of UV-A radiation with the dexterity and pinpoint accuracy of a surgeon's scalpel.



-
1. Liquid Magnum shown in use on aerospace parts.
 2. Liquid Magnum Kit packaged in tool control system
 3. 2-Meter Light Guide
 4. Liquid Magnum use with REL Star Testing Panel showing defect image

Liquid Magnum Certifications & Compliances

- TESTED & COMPLIES with ROLLS-ROYCE RRES 90061
- AIRBUS AITM 6-1001
- ISO 3059
- 2 YEAR WARRANTY GUARANTEE
- SERIALIZED CERTIFICATE of CONFORMANCE

Liquid Magnum Features and Benefits

- Easy to use controls with clear indicators for lamp on/off operation
- 10mm diameter Liquid light source!



C4 NOMAD LED UV-A LAMP

Tested & Complies with



ASTM E3022
STANDARD

Tested & Complies with

Rolls-Royce
RRES 90061
REQUIREMENTS

Meets Specifications



ISO 3059

Tested & Complies with

AIRBUS
AITM 6-1001

POWERED BY
M18 REDLITHIUM

Directions For Use:

1. Remove from tool control solution.
2. Drop
3. Kick
4. Use

*Note: Steps 2-4 can be performed in any order!



C4 NOMAD & NOMAD-GO LED UV-A CHARACTERISTICS

<i>Performance Attributes</i>	<i>Parameters</i>
Maximum Irradiance (at 15 in/38cm)	5000 $\mu\text{W}/\text{cm}^2$
Peak Wavelength	365 \pm 5 nm
Irradiance at Peak Wavelength (at 15 in)	> 200 $\mu\text{W}/\text{cm}^2$
Typical Irradiated Area (profile at 15 in)	Circular Spot 10" Diameter
	> 1000 $\mu\text{W cm}^2$ (347-382 nm)
Emission Spectrum	
Full Width at Half Maximum (FWHM)	\leq 15 nm
Longest Wavelength at Half Max (LWHM)	\leq 380 nm
Full width at 10% Maximum	\leq 30 nm (\pm 15)
Excitation Irradiance (347-382 nm)	> 2500 $\mu\text{W}/\text{cm}^2$
Wavelength Drift (at 70° F ambient)	\leq 3 nm
Working Distances	
	ASTM E3022 Minimum WD \leq 5 in
	RRES 90061 Minimum WD = 12 in
	Maximum WD = 23"
Typical Visible Emission	
	ASTM E3022 range (400-760 nm) \leq 2 ft candles
	RRES 90061 range (390-800 nm) \leq 20 lux at 15 in

<i>Physical Attributes</i>	<i>Parameters</i>
Operating Environment	32 - 120° F
Maximum Housing Temperature (at 70° F ambient)	116° F
Power Supply Cord Length	18 V Lithium Ion Battery
Weight	3.2 lb
Approximate run time/per battery	2.5 hrs
Specification Compliance	ASTM E3022, RRES 90061, ISO 3059,
	Airbus AITM 6-1001

Emission Spectrum measured at Stabilization Temperature

10 inch diameter spot size
1000 $\mu\text{W}/\text{cm}^2$ at 15 inches away

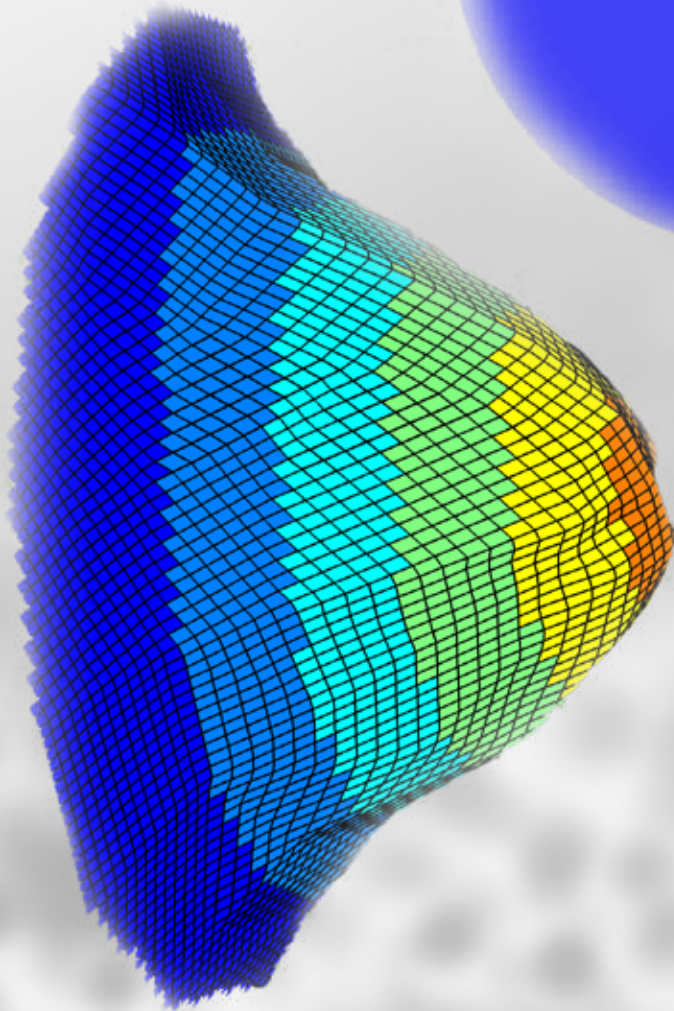
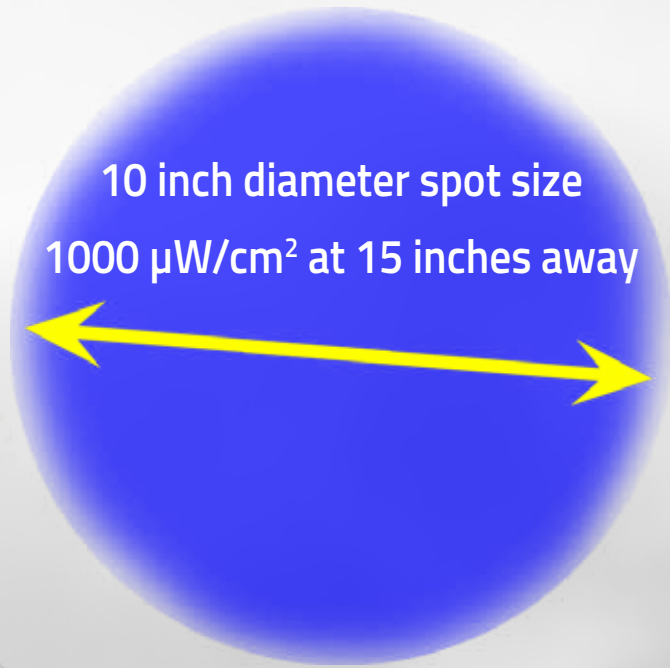
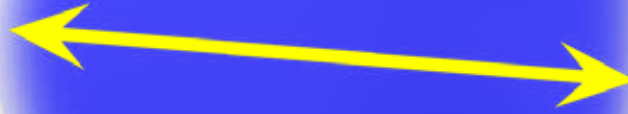

REL'S Nomad cordless UV-A inspection lamps are powered by M18



C4 NOMAD

The C4 Nomad is powered by the versatile Milwaukee M18 battery pack, allowing the operator to choose the optimal amp/hour battery best suited for their continuous use application. The C4 Nomad is designed for all intensity requirements of Fluorescent Penetrant Inspection (FPI) and Magnetic Particle Inspection (MPI). REL's C4 Nomad inspection lamps contain high flux UV-A and white light LED emitters with built-in static-electric discharge circuits.

The C4 Nomad provides a 10-inch diameter of UV-A intensity $>1000 \mu\text{W}/\text{cm}^2$ at 15 inches. The integral filter in the UV-A emitter limits the visible light to 20 lux (1.86 foot-candles) at 15 inches, and 5 lux (0.47 foot-candles) at 36 inches. The lamp performs in all environments regardless of ambient conditions. The C4 Nomad LED UV-A will survive the toughest, wettest, and most severe work environments on the planet!



-
1. C4 Nomad shown in use on a REL FPI line.
 2. REL M18 product integration feature.
 3. C4 Nomad lamp body run over by a 16,500 lb forklift!
 4. C4 Nomad shown with REL's Spray Can Fixture fits any REL hand-held lamp.

C4 Nomad & C4 Nomad-GO Certifications & Compliances

- TESTED & COMPLIES with ASTM E3022 STANDARD
- TESTED & COMPLIES with ROLLS-ROYCE RRES 90061
- AIRBUS AITM 6-1001
- ISO 3059
- 2 YEAR WARRANTY GUARANTEE
- SERIALIZED CERTIFICATE of CONFORMANCE

C4 Nomad & C4 Nomad-GO Features and Benefits

- Powered by Milwaukee RedLithium M18 battery pack system
- High output UV-A LED emitters with white light (Nomad-GO) emitter for darker inspection environments
- Easy to use controls with clear indicators for lamp on/off operation
- Built in static-electric discharge unit safety feature
- Individual lamp dimensions: 10.6" H x 3.0" W x 4.6" D
- Individual lamp weight: 3.2 lbs.
- Refurbishable
- Will not fall out of spec with Limiting Driver

C4 NOMAD: 3 WAYS TO BUY

UV-2400	Kit Includes
	<ul style="list-style-type: none">▪ Glo-Black C4 Nomad LED UV-A Lamp▪ 120V M18 Battery Charger▪ Two M18 2-Amp hour batteries▪ Tool control system▪ Safety glasses
UV-2400BT	Kit Includes
	<ul style="list-style-type: none">▪ Glo-Black C4 Nomad LED UV-A Lamp (Lamp only)▪ Safety glasses
470-00000	Kit Includes
  <i>"The only complete mobile testing kit available to the fleet."</i>	<p>FPI Mobile Testing Nomad Kit: Type 1, Method C</p> <ul style="list-style-type: none">▪ C4 Nomad LED UV-A Lamp▪ 120V M18 Battery Charger▪ Two M18 2-Amp hour batteries▪ 1 can penetrant▪ 1 can developer▪ 2 cans cleaner▪ Tool Control System with foam that is cross-linked polyethylene, resistant to jet fuel and hydraulic fluid.▪ Safety glasses▪ NSN: 6850-01-676-2205

C4 NOMAD ACCESSORIES

Part #	Description
UV-1025	Tool control system for Nomad Lamps
UV-1100	Lamp Mounting Arm
UV-2016	Domer & Ding Ring
470-00007	120V M18 Battery Charger
470-00008	M18 2-Amp hour Battery
UV-7000	Spray Can Fixture (Hands-Free Applicator)
UV-7400	SNAPSHOT-UV includes GoPro™ HERO9

ACCESSORY HIGHLIGHT

"REL, Inc. is an authorized Original Design Manufacturer (ODM) distributor of MILWAUKEE ELECTRIC TOOL CORPORATION."



C4 Nomad-GO & C4 Nomad shown integrated with M18 batteries.

POWERED BY
M18 REDLITHIUM



C4 NOMAD-GO

LED UV-A LAMP + WHITE LIGHT

Tested & Complies with



Tested & Complies with

Rolls-Royce
RRES 90061
REQUIREMENTS

Meets Specifications



Tested & Complies with

AIRBUS
AITM 6-1001

POWERED BY
M18 REDLITHIUM



Directions For Use:

1. Remove from tool control solution.
2. Drop
3. Kick
4. Use

*Note: Steps 2-4 can be performed in any order!



What do you get when you cross REL's C4 Magnum-GO with Milwaukee powered portability?



C4 NOMAD-GO

The C4 Nomad-GO is designed for all intensity requirements of Fluorescent Penetrant Inspection (FPI) and Magnetic Particle Inspection (MPI). REL's C4 Nomad-GO inspection lamps contain high flux UV-A and white light LED emitters with built-in static-electric discharge circuits. The C4 Nomad-GO provides a 10-inch diameter of UV-A intensity $>1000 \mu\text{W}/\text{cm}^2$ at 15 inches. The integral filter in the UV-A emitter limits the visible light to 20 lux (1.86 foot-candles) at 15 inches, and 5 lux (0.47 foot-candles) at 36 inches.

The LED white light provides an intensity > 700 -foot candles at 15 inches. The lamp's electrical components are sealed and passively cooled within an engineered finned housing manufactured from military-grade aluminum. The lamp performs in all environments regardless of ambient conditions. The C4 Nomad-GO LED UV-A with white light will survive the toughest, wettest, and most severe work environments on the planet!



1. C4 Nomad-GO in use on REL's FPI line Model I2C.
2. C4 Nomad-GO in use with REL's Spray Can Fixture.
3. C4 Nomad-GO lamp body run over by a 16,500 lb forklift!
4. REL Lamps survive the toughest, wettest, and most severe work environments.

C4 NOMAD-GO: 2 WAYS TO BUY

UV-3400



Kit Includes

- Glo-Black C4 Nomad-GO LED UV-A Lamp
- 120V M18 Battery Charger
- Two M18 2-Amp hour batteries
- Tool control system
- Safety glasses

UV-3400BT



Kit Includes

- Glo-Black C4 Nomad LED UV-A Lamp (Lamp only)
- Safety glasses

C4 NOMAD-GO ACCESSORIES

Part #	Description
UV-1025	Tool control system for Nomad Lamps
UV-1100	Lamp Mounting Arm
UV-2016	Domer & Ding Ring
470-00007	120V M18 Battery Charger
470-00008	M18 2-Amp hour Battery
UV-7000	Spray Can Fixture (Hands-Free Applicator)
UV-7400	SNAPSHOT-UV includes GoPro™ HERO9

ACCESSORY HIGHLIGHT

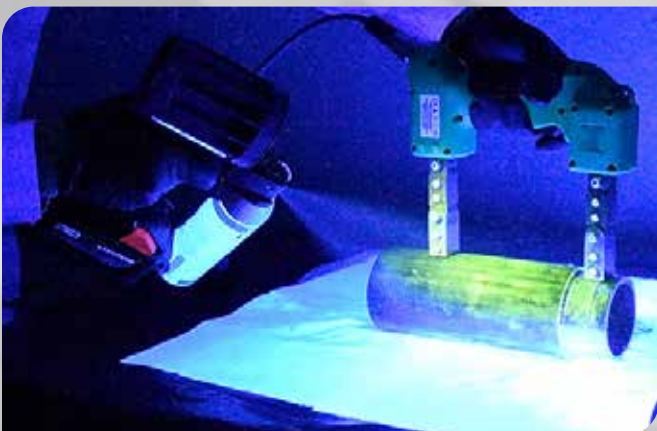

C4 Nomad-GO shown with Spray Can Fixture.

UV-7000

Spray Can Fixture

NOMAD-ASCENT

LED UV-A LAMP

Tested & Complies with



ASTM E3022
STANDARD

Tested & Complies with

Rolls-Royce
RRES 90061
REQUIREMENTS

Meets Specifications



ISO 3059

Tested & Complies with

AIRBUS
AITM 6-1001

Directions For Use:

1. Remove from tool control solution.
2. Drop
3. Kick
4. Use

*Note: Steps 2-4 can be performed in any order!

Hands-Free / Cord-Free UV Power



NOMAD-ASCENT: HOW TO BUY

UV-5400



Kit Includes

- Nomad-Ascent LED UV-A Lamp
- 4 - Batteries
- 2 - USB chargers
- Headband
- Pocket clip
- Tool control system
- Safety glasses

Nomad-Ascent

REL Glo-Black Nomad-Ascent: Brings mobility to indications discovered in the FPI process.

The Nomad-Ascent is the highest power density lamp in the UV-A inspection market. This lamp delivers a powerful uniform beam pattern from a compact rugged machined housing of military grade aluminum. The Nomad-Ascent features a solid state switch along with fluoroelastomer sealed interfaces to deliver a punch way above its weight class.



1. 3D printed, infinite variable angle-of-focus mount.
2. Hand-held comfort with snap on pocket clip, or utilize its magnetic base by sticking it to any ferrous metal surface.
3. 3D printed, closeup image of hands-free mount for the Nomad-Ascent.
4. Kit includes: Lamp with magnetic base, 4 Batteries with 2 USB Chargers, Headband, Pocket clip, Tool control system

Nomad-Ascent Certifications & Compliances

- TESTED & COMPLIES with ASTM E3022 STANDARD
- TESTED & COMPLIES with ROLLS-ROYCE RRES 90061
- AIRBUS AITM 6-1001
- ISO 3059
- IP67 RATED
- 5 YEAR WARRANTY GUARANTEE
- SERIALIZED CERTIFICATE of CONFORMANCE

Nomad-Ascent Features and Benefits

- 12-inch diameter spot above 1000 $\mu\text{W}/\text{cm}^2$ at startup
- 1.5 + hour run time with each 5000 mAh li-ion battery
- Quad-lead thread for quick single turn battery removal
- IP67 Rated (Tested in Carrier Fluid!)
- Lightweight - 7 ounces
- Magnetic base with 1/4-20 socket for fixed mounts
- Hard hat mountable
- Pocket clip

PROFUSION LED UV-A LAMP

Tested & Complies with



Tested & Complies with

Rolls-Royce
RRES 90061
REQUIREMENTS

Meets Specifications



Tested & Complies with

AIRBUS
AITM 6-1001





UV-4000DB shown

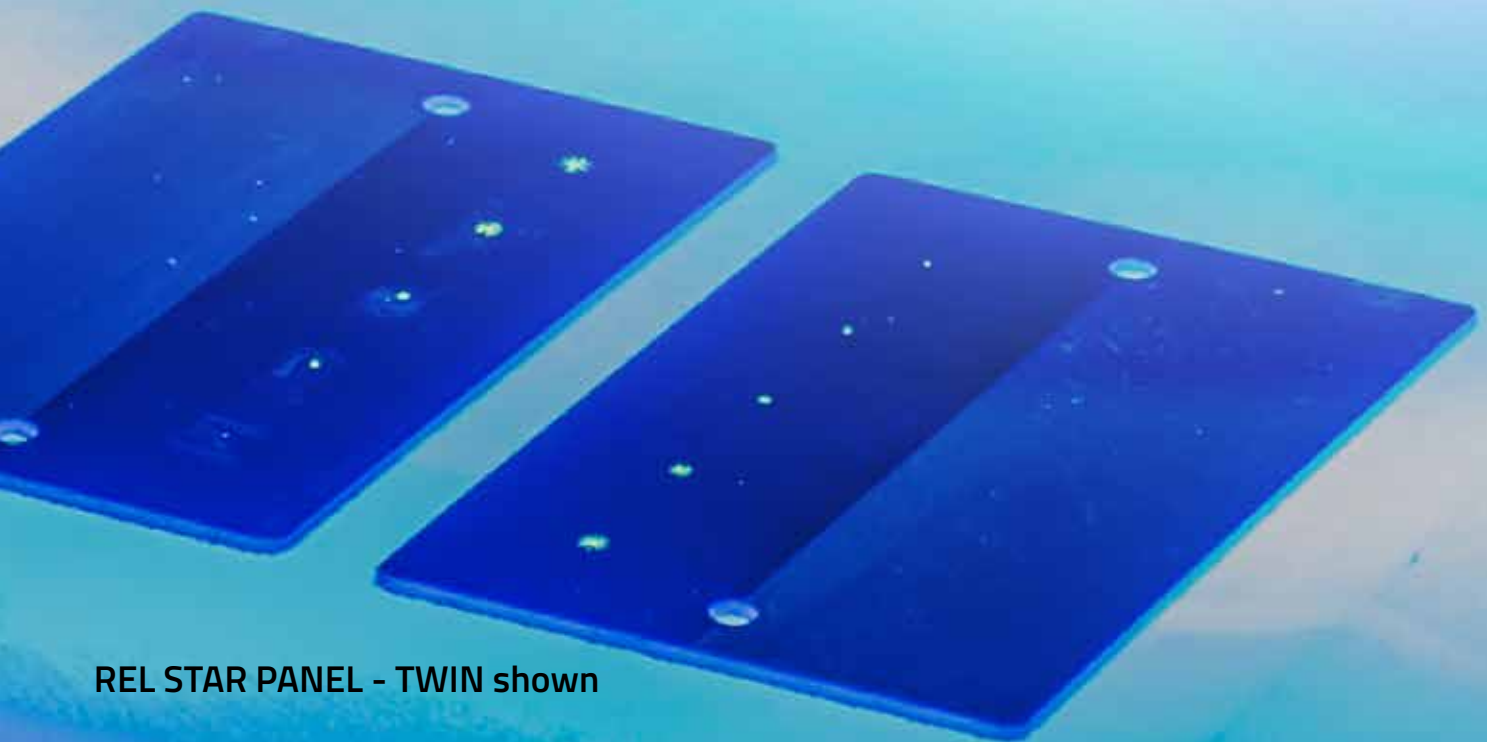

REL STAR PANEL - TWIN shown

PROFUSION CHARACTERISTICS

<i>Performance Attributes</i>	<i>Parameters</i>
Maximum Irradiance (at 15 in/38cm)	5000 $\mu\text{W}/\text{cm}^2$
Peak Wavelength	365 \pm 5 nm
Irradiance at Peak Wavelength (at 15 in)	> 200 $\mu\text{W}/\text{cm}^2$
Typical Irradiated Area (profile at 15 in)	Circular Spot 10" Diameter
	> 1000 $\mu\text{W cm}^2$ (347-382 nm)
Emission Spectrum	
Full Width at Half Maximum (FWHM)	\leq 15 nm
Longest Wavelength at Half Max (LWHM)	\leq 377 nm
Full width at 10% Maximum	\leq 30 nm (\pm 15)
Excitation Irradiance (347-382 nm)	> 2500 $\mu\text{W}/\text{cm}^2$
Wavelength Drift (at 70° F ambient)	\leq 3 nm
Working Distances	
ASTM E3022	Minimum WD \leq 5 in
RRES 90061	Minimum WD = 12 in
	Maximum WD = 23"
Typical Visible Emission	
ASTM E3022 range (400-760 nm)	\leq 2 ft candles
RRES 90061 range (390-800 nm)	\leq 20 lux at 15 in
	\leq 5 lux at 36"

<i>Physical Attributes</i>	<i>Parameters</i>
Operating Environment	32 - 115° F
Maximum Housing Temperature (at 70° F ambient)	104° F
Lamp Cord Length	10 ft standard
Power Supply Cord Length	Sized per array
Weight	3.08 lb (1 module)
Specification Compliance	ASTM E3022, RRES 90061, ISO 3059,
	Airbus AITM 6-1001

Emission Spectrum measured at Stabilization Temperature

Single lamp module

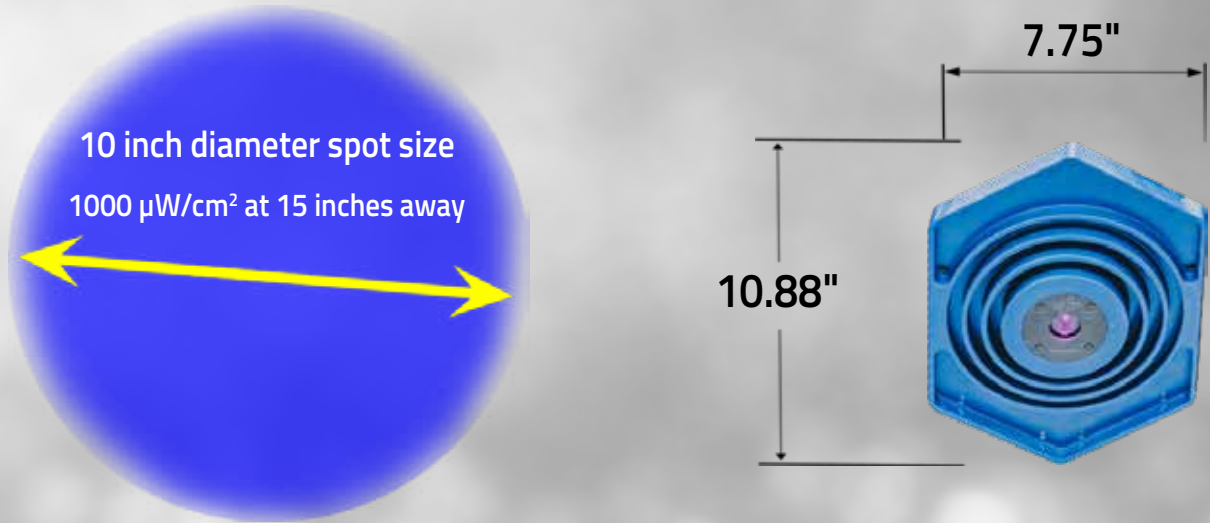

UV-4000TB (3 lamp module)

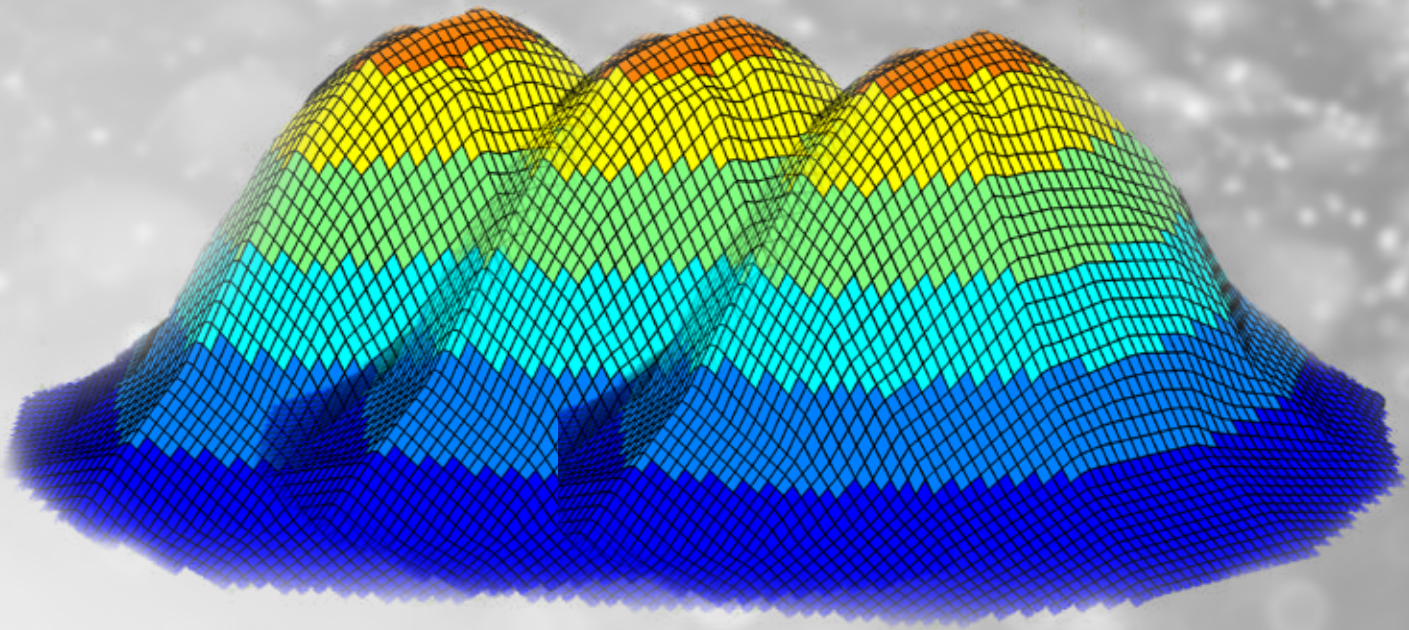
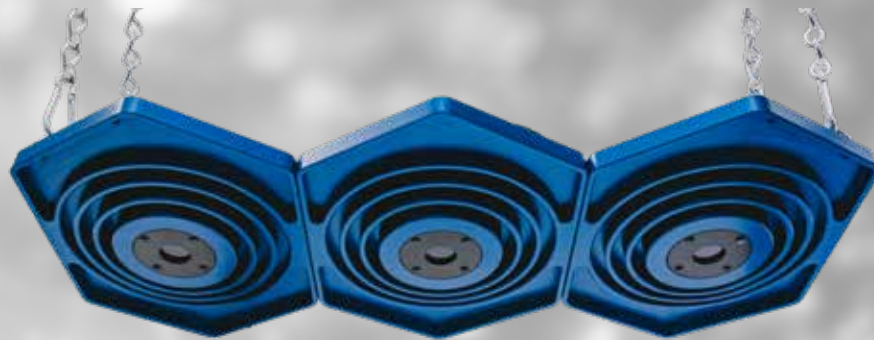

PROFUSION VERSUS 4 FT FLUORESCENT BULBS

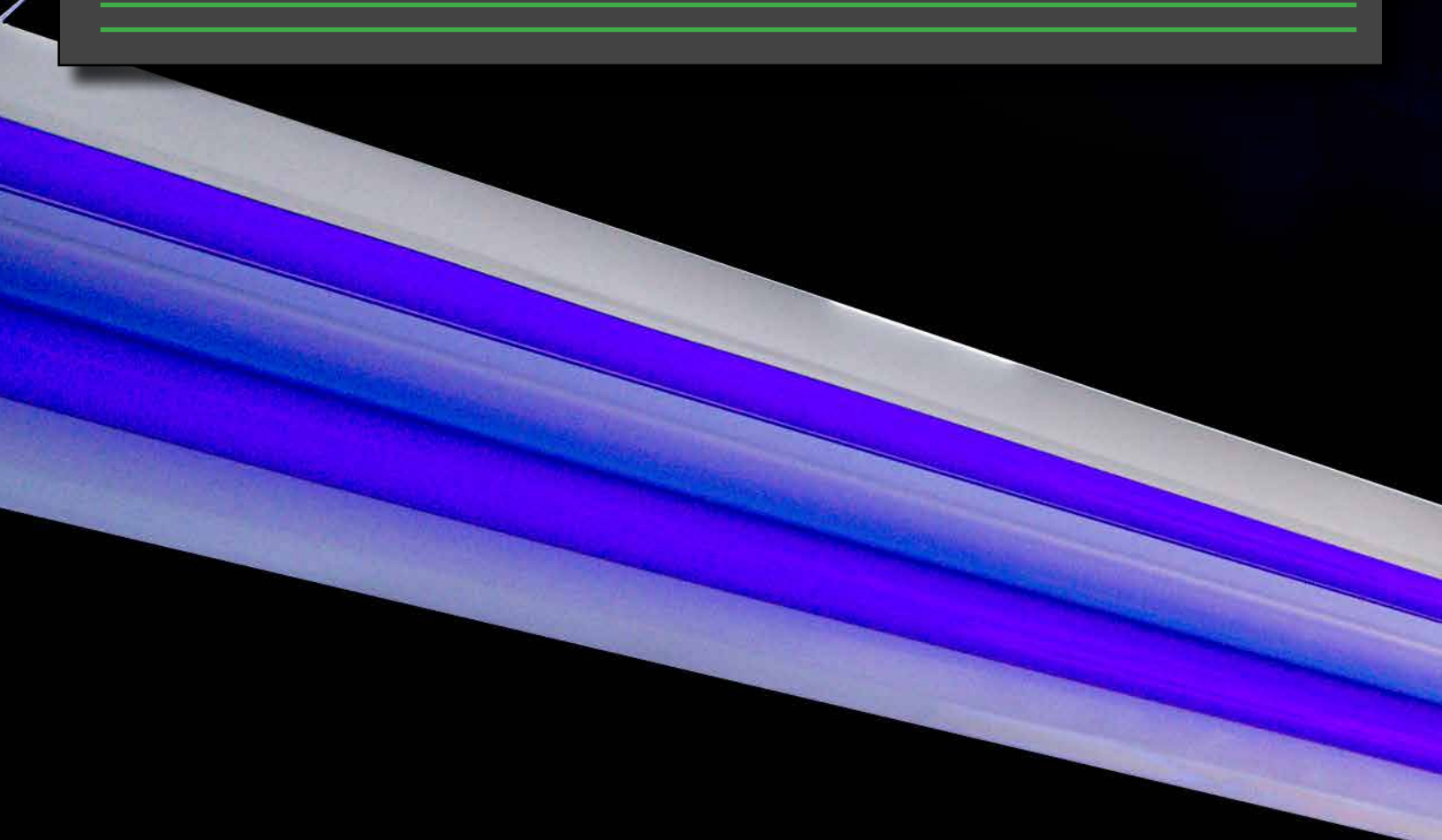

Single Profusion

Two 4 ft mercury vapor bulbs

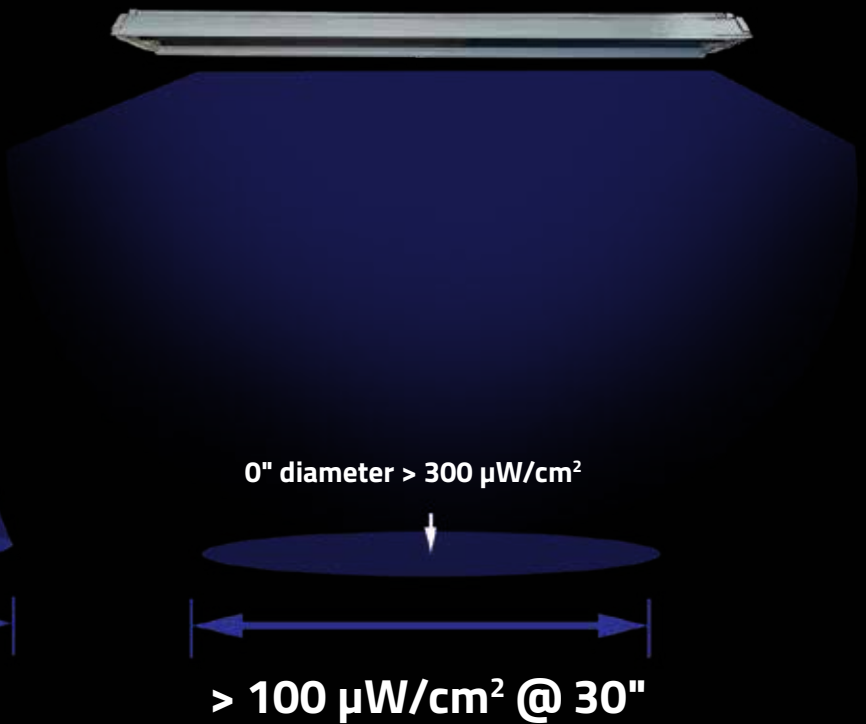
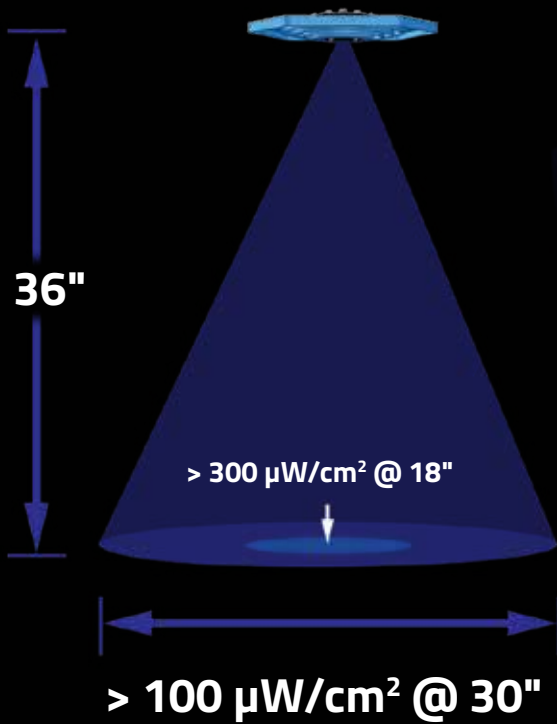



1 Profusion = 1 fluorescent fixture

PROFUSION COMMON CONFIGURATIONS

Coverage Area
>1000 $\mu\text{W}/\text{cm}^2$

Triple Bank

Double Bank

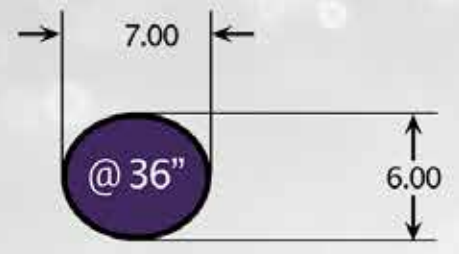
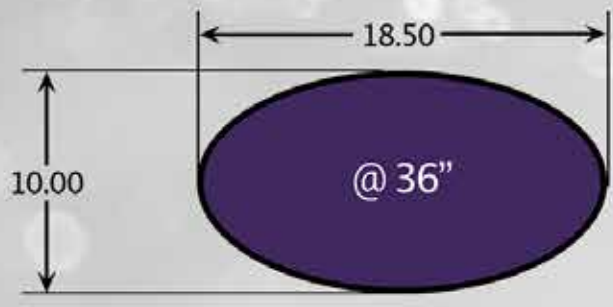
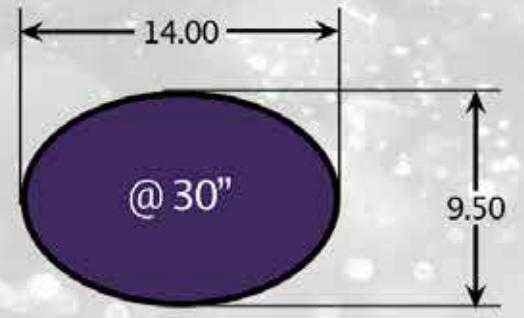
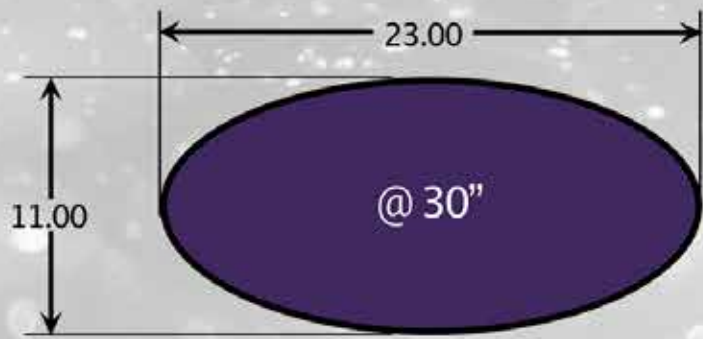
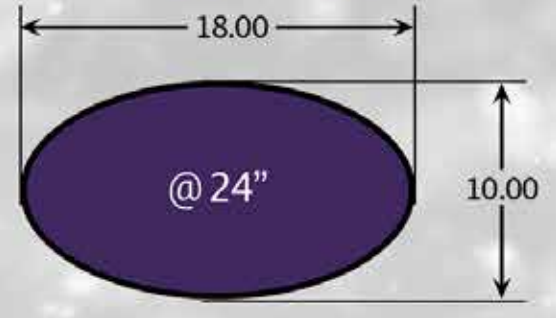
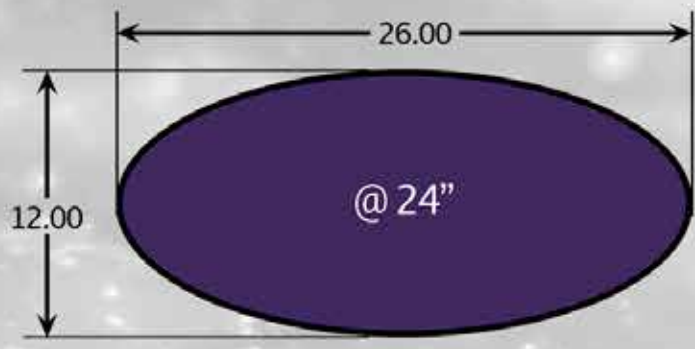

PROFUSION

REL's classic Profusion overhead UV-A inspection lamps are an expandable and configurable modular system for stationary non-destructive testing applications.

The Profusion is designed for all intensity requirements of Fluorescent Penetrant Inspection (FPI) and Magnetic Particle Inspection (MPI). Each Profusion module provides a 10-inch diameter of UV-A intensity above 1000 $\mu\text{W}/\text{cm}^2$ at 15 inches. The integral filter in the Profusion limits the visible light to 20 lux at 15 inches and 5 lux at 36 inches. Each Profusion module contains LED emitters with a built-in static-electric discharge circuit.

The lamp's electrical components are sealed and passively cooled with an engineered finned housing manufactured from military-grade aluminum. The IP68 rated housing allows the lamp to perform in all environments regardless of ambient conditions.

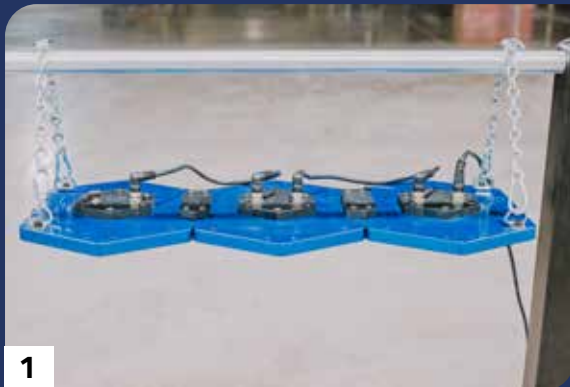

1. UV-4000TB with Profusion Hanging Hardware Kit, and Profusion Joining Plate & Connecting Wire Kit.
2. Glo-Black Profusions survive the toughest, wettest, and most severe work environments.
3. UV-4000 (1 lamp module) with Profusion Hanging Hardware Kit.
4. Profusion modules in a Inspection booth on REL's human-driven I2C FPI line.

Profusion Certifications & Compliances

- TESTED & COMPLIES with ASTM E3022 STANDARD
- TESTED & COMPLIES WITH ROLLS-ROYCE RRES 90061
- AIRBUS AITM 6-1001
- ISO 3059
- IP68 RATED - DUST SEALED & WATERPROOFED
- 2 YEAR WARRANTY GUARANTEE
- SERIALIZED CERTIFICATE of CONFORMANCE

Profusion Features and Benefits

- Modular & conformable system available in single, double bank, triple bank, or custom configurations
- 10-inch diameter of UV-A intensity above 1000 $\mu\text{W}/\text{cm}^2$ at 15 inches
- Integral filter limits visible light to 20 lux at 15 inches and 5 lux at 36 inches
- Low Voltage (Lamp input voltage 24V)
- Built-in static-electric discharge unit safety feature
- Clear indicators for lamp on/off operation
- Passive cooling via engineered finned housing with military-grade aluminum
- Power Supply input Voltage 100V - 240V AC
- Individual lamp module dimensions: 10.88" H x 7.75" W
- Individual lamp module weight (not including mounting hardware): 3.08 lbs.
- Refurbishable

PROFUSION: COMMON WAYS TO BUY

UV-4000 (1 lamp module)	Kit Includes
	<ul style="list-style-type: none"> ▪ Glo-Black Profusion LED UV-A Lamp Module ▪ 120/240V, 60W Power Supply ▪ 10' DC Extension Power Cord ▪ Profusion Hanging Hardware Kit
UV-4000DB (2 lamp module)	Kit Includes
	<ul style="list-style-type: none"> ▪ 2 - Glo-Black Profusion LED UV-A Modules ▪ 120/240V, 60W Power Supply ▪ 10' DC Extension Power Cord ▪ Profusion Connecting Kit ▪ Profusion Hanging Hardware Kit
UV-4000TB (3 lamp module)	Kit Includes
	<ul style="list-style-type: none"> ▪ 3 - Glo-Black Profusion LED UV-A Modules ▪ 120/240V, 60W Power Supply ▪ 10' DC Extension Power Cord ▪ 2 - Profusion Connecting Kits ▪ Profusion Hanging Hardware Kit
4 lamp array	Kit Includes
	<ul style="list-style-type: none"> ▪ 4 - Glo-Black Profusion LED UV-A Modules ▪ 120/240V, 120W Power Supply ▪ 10' DC Extension Power Cord ▪ 3 - Profusion Connecting Kits ▪ Profusion Hanging Hardware Kit
5 lamp array	Kit Includes
 <p data-bbox="240 1814 456 1839">* Sample set-up shown</p>	<ul style="list-style-type: none"> ▪ 5 - Glo-Black Profusion LED UV-A Modules* ▪ 120/240V, 120W Power Supply ▪ 10' DC Extension Power Cord ▪ 4 - Profusion Connecting Kits ▪ Profusion Hanging Hardware Kit

PROFUSION ACCESSORIES

Part #	Description
UV-1100	Lamp Mounting Arm
UV-2007	10' DC Extension Power Cord
UV-2023	120/240V, 60W Power Supply
UV-2030	Profusion Joining Plate & Connecting Wire Kit
UV-2031	120/240V, 120W Power Supply (4-7 Profusion Modules)
UV-4010	Swivel Mount Lamp Holder
UV-4015	Profusion Hanging Hardware Kit
UV-4200	Profusion Switch Block (includes power supply)
UV-7100	25W Wall Mount Power Supply

PROFUSION HIGHLIGHT

Versatility



Seven Glo-Black Profusion LED UV-A modules shown linked together with Profusion Joining Plates & Connecting Wires, and Hanging Hardware.

PROFUSION XW

LED UV-A LAMP

Tested & Complies with



ASTM E3022
STANDARD

Meets Specifications



ISO 3059

Tested & Complies with

AIRBUS

AITM 6-1001



PROFUSION XW CHARACTERISTICS

<i>Performance Attributes</i>	<i>Parameters</i>
Maximum Irradiance (at 24 in/38cm)	10000 $\mu\text{W}/\text{cm}^2$
Peak Wavelength	365 \pm 5 nm
Emission Spectrum	
Full Width at Half Maximum (FWHM)	\leq 15 nm
Longest Wavelength at Half Max (LWHM)	\leq 377 nm
Full width at 10% Maximum	\leq 30 nm (\pm 15)
Excitation Irradiance (347-382 nm)	$>$ 7000 $\mu\text{W}/\text{cm}^2$
Wavelength Drift (at 70° F ambient)	\leq 1 nm
Typical Visible Emission	
range (400-760 nm)	\leq 2 ft candles at 24 in
	\leq 20 lux at 24 in

<i>Physical Attributes</i>	<i>Parameters</i>
Operating Environment	32 - 115° F
Maximum Housing Temperature (at 70° F ambient)	88 ° F
Lamp Cord Length	10 ft Standard
Power Supply Cord Length	10 ft
Weight	5.8 lb
Power in	100-240V AC / 50 - 60Hz
Specification Compliance	ISO 3059, ASTM E3022, Airbus AITM 6-1001

Emission Spectrum measured at Stabilization Temperature



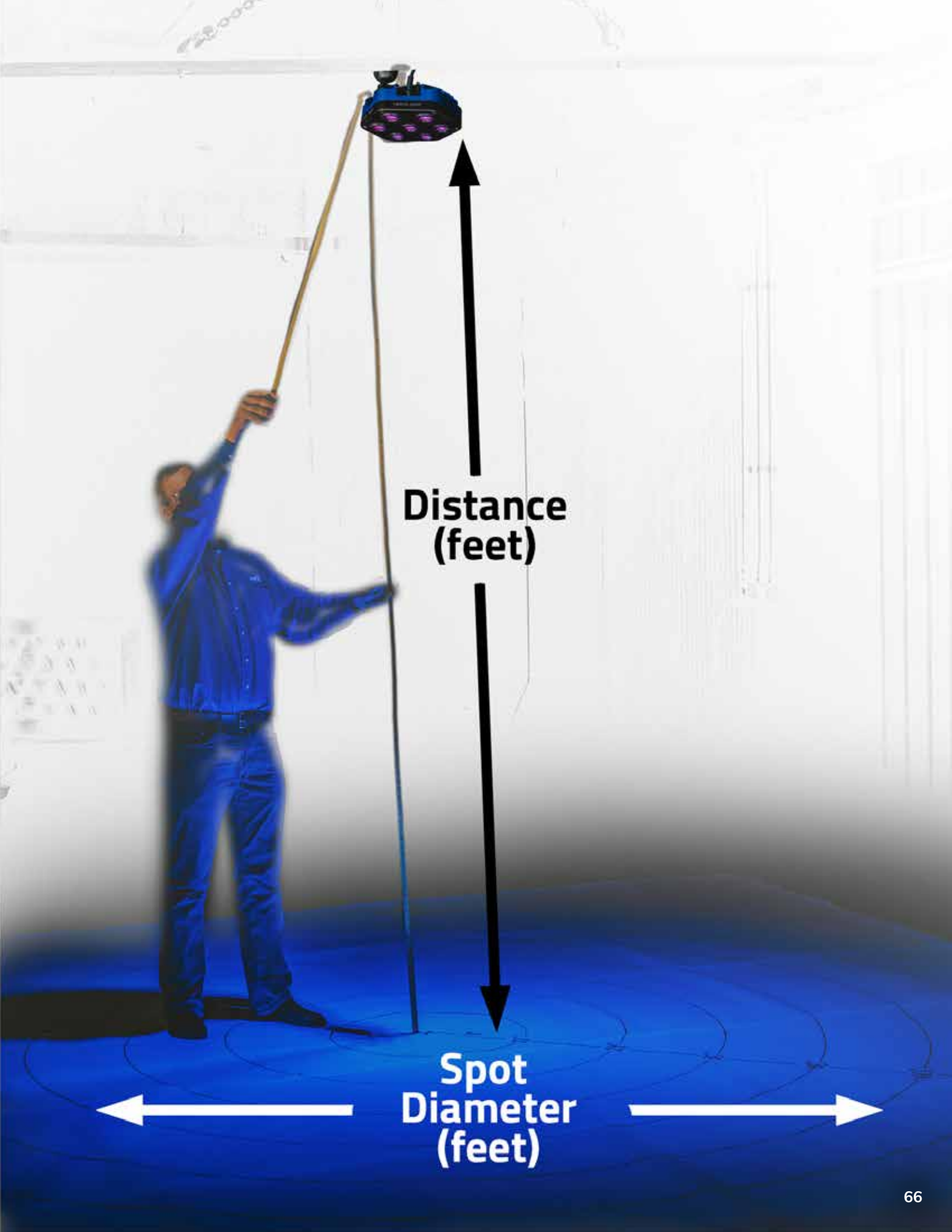

**Distance
(feet)**

**Spot
Diameter
(feet)**

PROFUSION XW



> 1000 $\mu\text{W}/\text{cm}^2$ at
4 feet away

28 inches



> 100 $\mu\text{W}/\text{cm}^2$ at
4 feet away

60 inches

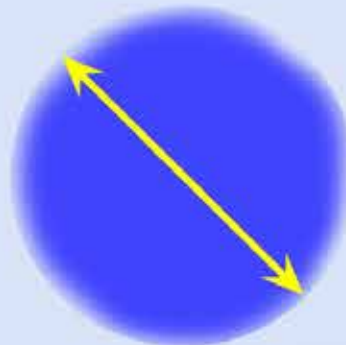



> 300 $\mu\text{W}/\text{cm}^2$ at
4 feet away

46 inches



> 300 $\mu\text{W}/\text{cm}^2$ at
9 feet away

48 inches

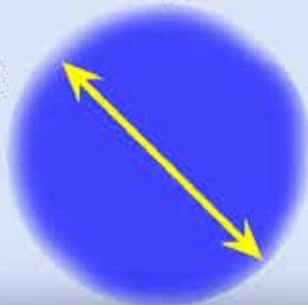

> 100 $\mu\text{W}/\text{cm}^2$ at
9 feet away

82 inches



PROFUSION XW PERFORMANCE DATA

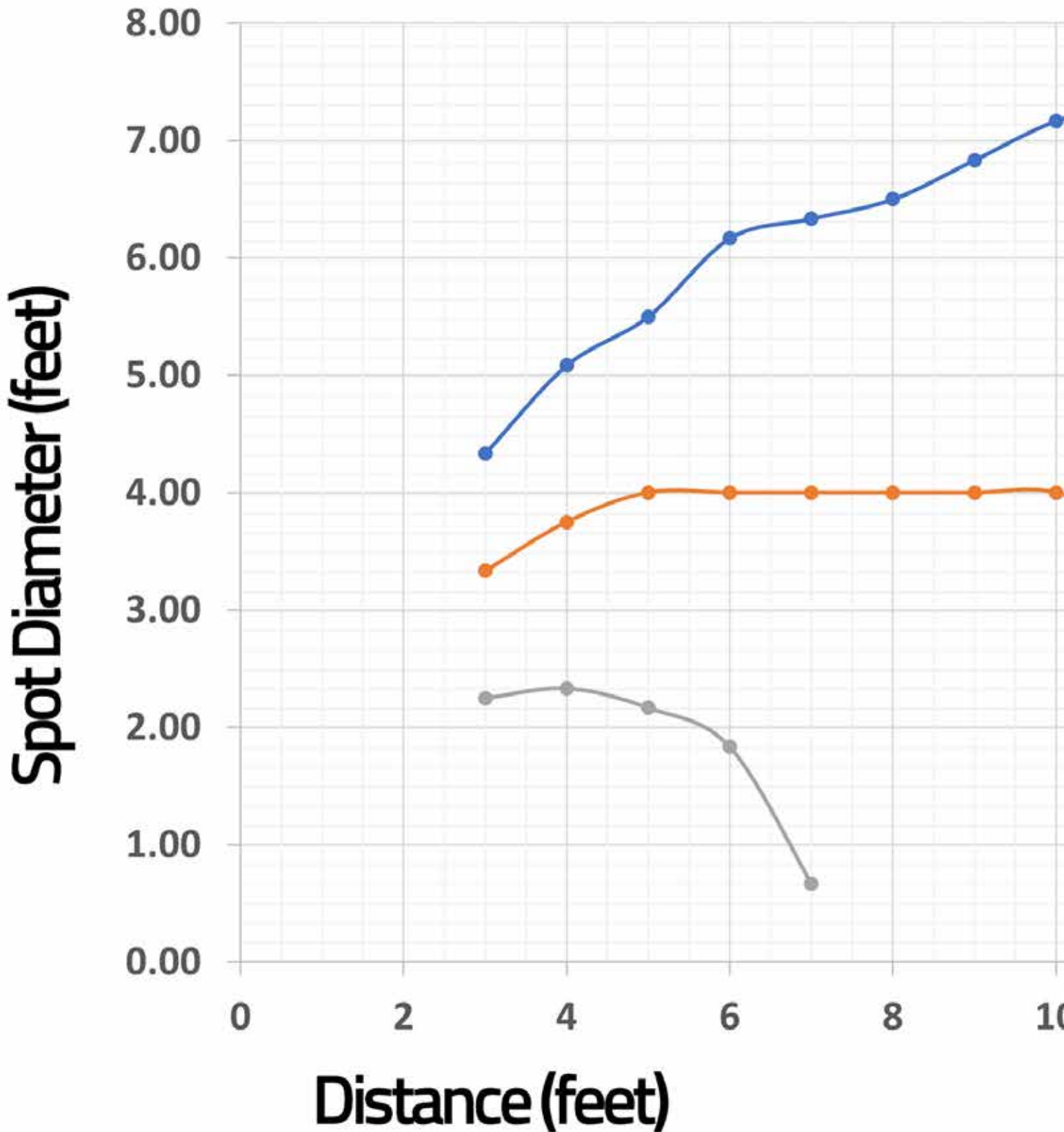

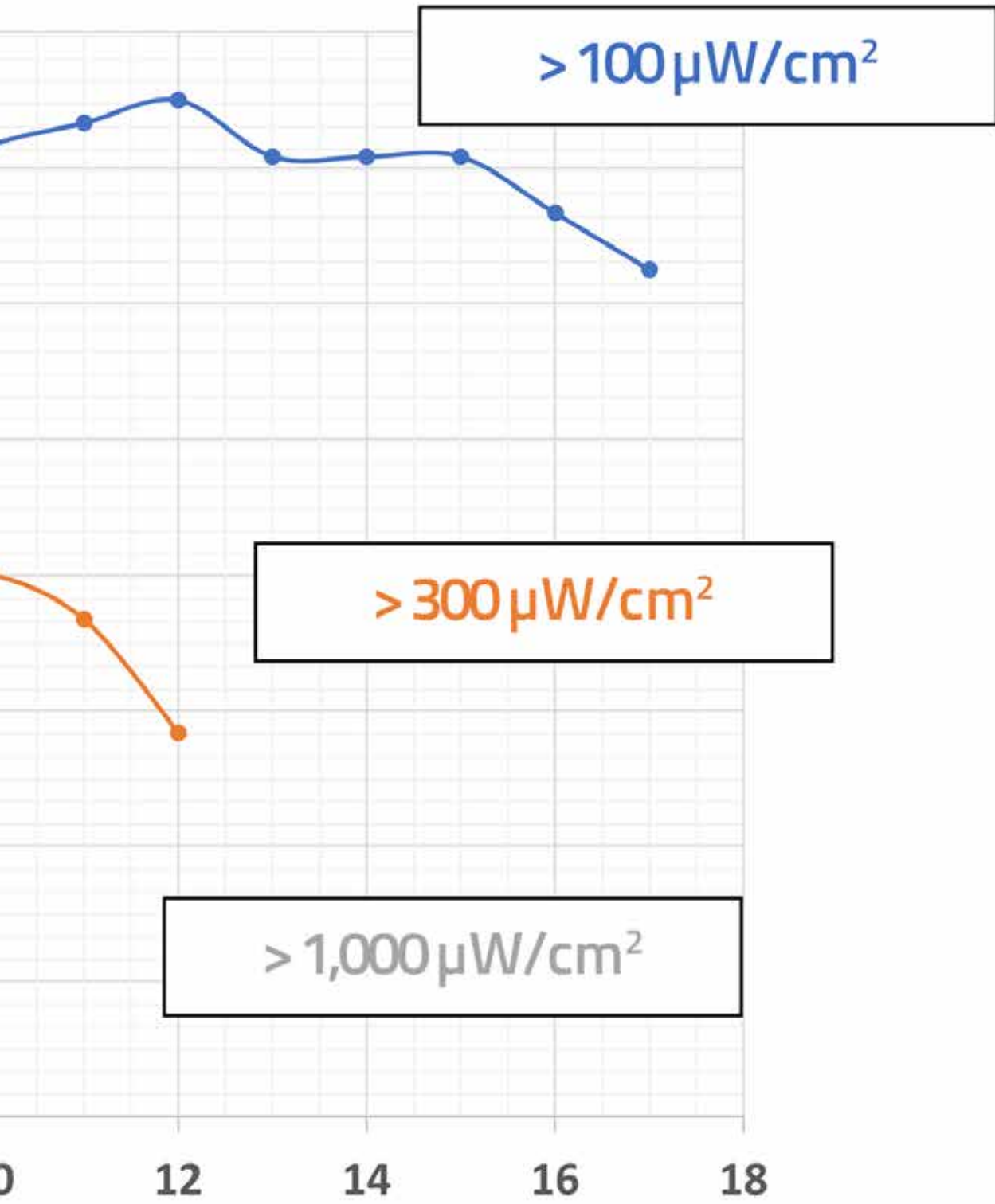

PROFUSION XW: HOW TO BUY

UV-4700	Kit Includes
	<ul style="list-style-type: none"> ▪ Glo-Black Profusion XW Lamp ▪ 120/240V, 120W Power Supply ▪ 10' DC Extension Power Cord ▪ Swivel Mount Lamp Holder ▪ Tool control system ▪ Safety glasses

PROFUSION XW ACCESSORIES

Part #	Description
UV-1100	Lamp Mounting Arm
UV-2031	120/240V, 120W Power Supply
UV-4010	Swivel Mount Lamp Holder
UV-4015	Profusion Hanging Hardware Kit
TRM-100	Tripod Kit, Adjustable Tripod with ball head, 12" - 62" height, 27lb capacity, ARCA adapter

PROFUSION XW

Massive amounts of UV-A wavelength emission in a small package!
The Profusion XW is the perfect light for larger FPI and MPI non-destructive testing environments. The design of this package was demanded by aerospace and space companies that produce parts that are over 100 feet in length. Integration of heat sinks and cooling are a foundational part of this lamp's design.

REL's Profusion XW IP68 rated overhead lamp builds on the classic Profusion to offer 7x higher output and wider coverage area in a lamp head of equal frontal area.



Profusion XW Certifications & Compliances

- TESTED & COMPLIES with ASTM E3022 STANDARD
- AIRBUS AITM 6-1001
- ISO 3059
- IP68 RATED - DUST SEALED & WATERPROOFED
- 2 YEAR WARRANTY GUARANTEE
- SERIALIZED CERTIFICATE of CONFORMANCE

Profusion XW Features and Benefits

- 7x the intensity of the classic Profusion Lamp
- High Intensity UV-A light emitters for wide coverage areas
- 100% continuous duty at full output
- Engineered fin housing allows for maximum heat transfer in the harshest environments
- Built-in static-electric discharge unit safety feature
- AC: 120/240V
- Individual lamp dimensions: 8" H x 7.25" W

REL STAR TESTING PANEL

Certification for GE Aviation Process Specification P3TF47



3x magnification

Twin Panels shown

HEXAVALENT CHROMIUM FREE





REL Designed Green 

Panel plating is designed to comply with RoHS, REACH, WEE, ELV, and Proposition 65.

REL Certified 

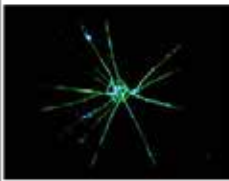
REL Star Testing Panels meet the requirements as stated in ASTM E1417, MIL-STD-6866, TO 33B-1-1, NAVAIR 01-1A-16-1, and TM 1-1500-335-23. The REL Star Testing Panels have been manufactured and tested in accordance with the REL, Inc. procedure RWI-1105.

PENETRANT SYSTEM MONITORING PANEL DOCUMENTATION

SN# 80077188					
Crack Position	A	B	C	D	E
Photo of Defect					
Magnification Factor:	1 : 5.5				
Measured Size [Inch]	0.183	0.142	0.081	0.050	0.030
Specification [Inch]	0.180 - 0.250	0.125 - 0.171	0.075 - 0.093	0.046 - 0.062	0.015 - 0.031
Measured Size [mm]	4.65	3.61	2.06	1.27	0.76
Specification [mm]	4.57 - 6.35	3.18 - 4.34	1.91 - 2.36	1.17 - 1.57	0.38 - 0.79

Crack Depth	.0025" ± .0001"	63 μm ± 2.5μm
-------------	-----------------	---------------



REL Star Testing Panel - Single
(Part Number: 250-00104)

REL Star Testing Panel - Twin
(Part Number: 250-00103)

Each REL Star Testing Panel includes documentation, protective case, and foam sleeve for panel.

REL Star Testing Panel and Documentation included:

1. Case w/ panel certification,
2. Serialized crack size certification documents, and
3. Five (5) pictures of the manufactured defects.

FPI MOBILE TESTING KIT

**FPI MOBILE TESTING
NOMAD
TYPE 1, METHOD C
PART # 470-00000
CAGE CODE: 5DLA1
NSN: 6850-01-676-2205**

1. 120V CHARGER 470-00007
2. C4 NOMAD 470-UV-2400
3. 18V BATTERY 470-00008
4. 18V BATTERY 470-00008
5. 1 CAN PENETRANT 470-00006
6. 1 CAN DEVELOPER 470-00005
7. 1 CAN CLEANER 470-00004
8. 1 CAN CLEANER 470-00004

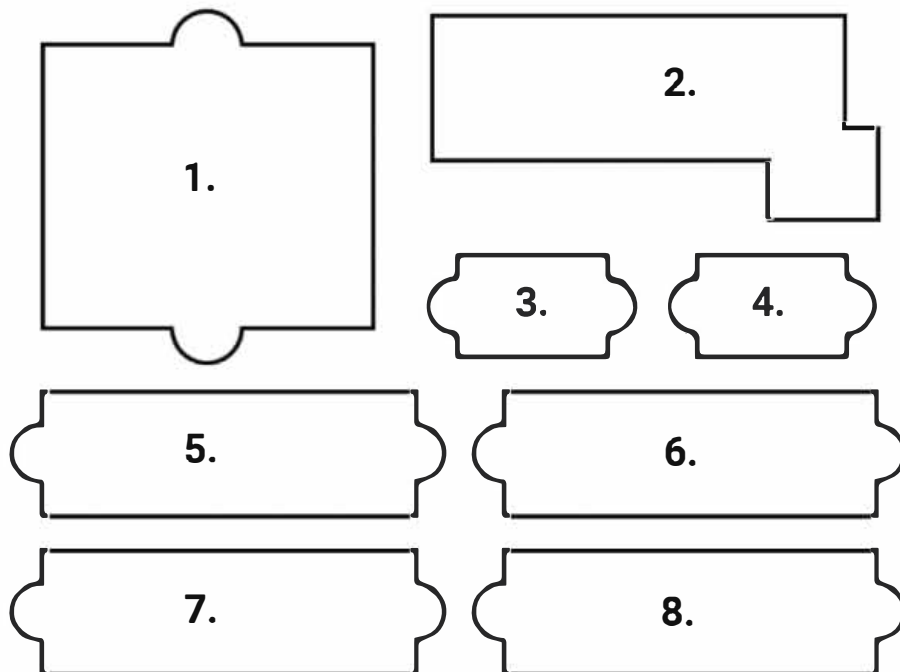

Part #	Description
470-00000	<p>FPI Mobile Testing Nomad Kit: Type 1, Method C</p> <ul style="list-style-type: none">▪ C4 Nomad LED UV-A Lamp▪ 120V M18 Battery Charger▪ Two M18 2-Amp hour batteries▪ 1 can penetrant▪ 1 can developer▪ 2 cans cleaner▪ Tool Control System with foam that is cross-linked polyethylene, resistant to jet fuel and hydraulic fluid.▪ Safety glasses▪ NSN: 6850-01-676-2205



"The only complete mobile testing kit available to the fleet."



SNAPSHOT-UV

Record your indications with
REL integrated GoPro™ HERO9



SNAPSHOT-UV
mounted on a C4 Nomad-GO

SNAPSHOT-UV

REL Glo-Black SNAPSHOT-UV: Brings traceability to indications discovered in the FPI process.

The Glo-Black Snapshot-UV was developed with the casting industry to support traceability in the FPI process through capturing digital pictures of indications in real time. REL integrated a GoPro™ on the top of handheld Glo-Black lamps. The focal distance and direction were designed to capture indications to facilitate a digital transformation to your FPI inspection process.

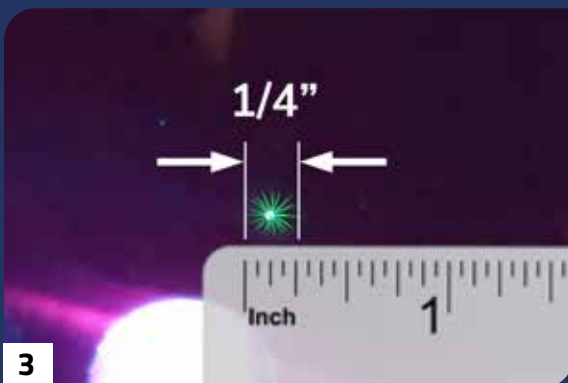
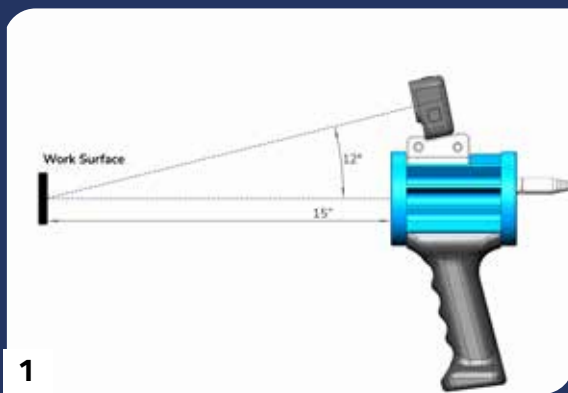

1. 12 deg camera angle optimized for inspection at 15 inches
2. Hands free camera with macro lens focused for recording images clearly at 15 inches
3. SNAPSHOT-UV image of a 1/4" indication on KDS panel
4. Kit includes: GoPro™ HERO9, mounting bracket, remote, wrench, 2 batteries with charger, 64GB SD card, 2 USB-C cords

BOLT ON POWER



lift point



Abrasion
Resistant



Durable



Prevent
Breakage





REL PRODUCT INTEGRATION

"REL, Inc. is an authorized Original Design Manufacturer (ODM) distributor of MILWAUKEE ELECTRIC TOOL CORPORATION."

C4 Nomad UV-2400



C4 Nomad-GO UV-3400



120 Volt M18 Battery Charger



POWERED BY
M18 REDLITHIUM

Two M18 2-Amp hour Batteries included in kit

TOOL CONTROL SYSTEMS

Eliminate workplace FOD (Foreign Object Debris)



UV-2000 Magnum
UV-3000 Magnum-GO



UV-2400 Nomad
UV-3400 Nomad-GO











UV-2100 Liquid Magnum



UV-2200 Liquid Nomad

LED UV-A LAMP ACCESSORIES

UV-1000	Description
 A black metal bench adapter with a clamp and a threaded rod.	Bench Adapter/Lamp Holder
UV-1020	Description
 A black ruggedized case with a handle and a logo.	Tool control system for Magnum Lamps
UV-1025	Description
 A black ruggedized case with a handle and a logo.	Tool control system for Nomad Lamps
UV-1100	Description
 A black metal lamp mounting arm with a clamp and a threaded rod.	Lamp Mounting Arm

UV-2007	Description
	<p>10' DC Extension Power Cord</p>
UV-2014	Description
	<p>Bolt on Power Cord for Magnum</p>
UV-2015	Description
	<p>Bolt on Power Cord for Magnum-GO</p>
UV-2016	Description
	<p>Domer & Ding Ring Kit</p>
UV-2021	Description
	<p>Case with foam and label NSN: 6240-01-700-3159</p>

UV-2023	Description
	<p>120/240V, 60W DC Power Supply</p>
UV-2030	Description
	<p>Profusion Joining Plate & Connecting Wire Kit</p>
UV-2031	Description
	<p>120/240V, 120W Power Supply (4-7 Profusion Modules)</p>
UV-2120	Description
	<p>2-Meter Light Guide</p>
UV-2200	Kit Includes
	<ul style="list-style-type: none"> ▪ Glo-Black Liquid Nomad LED UV-A Lamp ▪ 2-Meter Light Guide ▪ 120V M18 Battery Charger ▪ Two M18 2-Amp hour batteries ▪ Swivel Mount Lamp Holder ▪ Tool control system ▪ Safety glasses
UV-4010	Description
	<p>Swivel Mount Lamp Holder</p>

UV-4015	Description
	Profusion Hanging Hardware Kit
UV-4200	Description
	Profusion Switch Block (includes power supply)
UV-7000	Description
	Spray Can Fixture (Hands-Free Applicator)
UV-7100	Description
	25W Wall Mount Power Supply
UV-7400	Description
	Snapshot-UV includes GoPro™ HERO9, mounting bracket, remote, wrench, 2 batteries with charger, 64GB SD card, and 2 USB-C cords.

TRM-100	Description
	<p>Tripod Kit, Adjustable Tripod with ball head, 12" - 62" height, 27lb capacity, ARCA adapter</p>
470-00007	Description
	<p>120 Volt M18 Battery Charger</p>
470-00008	Description
	<p>M18 Battery, 2.0 amp hour</p>
250-00103	Description
	<p>REL Star Testing Panel - Twin</p>
250-00104	Description
	<p>REL Star Testing Panel - Single</p>



REL, Inc.
57640 North Eleventh St.
Calumet, MI 49913
USA

 **MADE IN
THE USA**

906-337-3018
rel@relinc.com

relinc.com