



INSTALLATION MANUAL

FUJI NDT SYSTEMS FILM PROCESSOR

FIP4000

INTRODUCTION

This installation manual contains information for carrying out the necessary steps prior to the installation of the FIP4000 Fuji Industrial X-ray Film Processor. It is important that familiarity with the information set forth in this manual be acquired so as to obtain optimum performance from the processor and facilitate the entire operation. When installing the processor, it is recommended that your Fuji Film technical representative be consulted for an optimum layout.

BEFORE INSTALLATION OF THE FIP4000

1. The room space and work flow should be given adequate consideration when determining the installation layout.
 - Refer to the section on "LAYOUT".
2. Examine the environmental conditions of the room where the processor is to be installed and make changes if necessary to meet environmental requirements.
 - Refer to the section on "ENVIRONMENT".
3. Prior to installation be sure that your electrical power service is adequate. If it is inadequate, arrange for the necessary increase in amperage and call in an electrician to do the necessary work.
 - Consult an electrician.
4. Prior to installation be sure that plumbing standards are met for the particular water supply system to be used and complete plumbing procedures before the processor is brought in.
 - Consult a plumber.
5. Divide the installation work into essential components (e.g., room partitioning, plumbing, and electrical work) and incidentals, and finish all work not directly related to actual processor connection.
 - Refer to the sections on "CONSTRUCTION ESSENTIAL TO INSTALLATION" and "INCIDENTAL WORK".

-----CONTENTS-----

1.	LAYOUT.....	4
1.	Installation Method.....	4
2.	Work Space.....	5
3.	Darkroom Lighting.....	5
2.	EXTERNAL VIEW AND DIMENSIONS.....	6
1.	FIP4000 and Accessories.....	6
2.	Fuji Automatic Feeder IX (Mounted on FIP4000).....	8
3.	ENVIRONMENTAL REQUIREMENTS.....	9
1.	Room Conditions.....	9
2.	Floor Conditions.....	9
4.	CONSTRUCTION ESSENTIAL TO INSTALLATION.....	10
1.	Foundation Work.....	10
2.	Room Partitioning.....	10
3.	Plumbing.....	12
4.	Plumbing Diagram.....	12
5.	Drainage.....	14
6.	Electrical Work.....	14
7.	Rack Hoist Installation.....	15
8.	Exhaust Duct Work.....	16
9.	Processor Transfer Route.....	16
5.	INCIDENTAL WORK.....	16
1.	Sink.....	16
6.	DATA REQUIRED FOR INSTALLATION.....	17
1.	Electrical System.....	17
2.	Ventilation System.....	17
3.	Water Supply and Drainage System.....	17
4.	Processor and Tank Weights.....	17
5.	Safelight.....	17
7.	CONNECTOR PORT DIMENSIONAL DIAGRAM.....	18
8.	SECTIONAL NOMENCLATURE.....	19
9.	ELECTRICAL CIRCUIT DIAGRAM.....	20

1. LAYOUT

■ INSTALLATION METHOD

« Standard Installation »

● Standard Layout

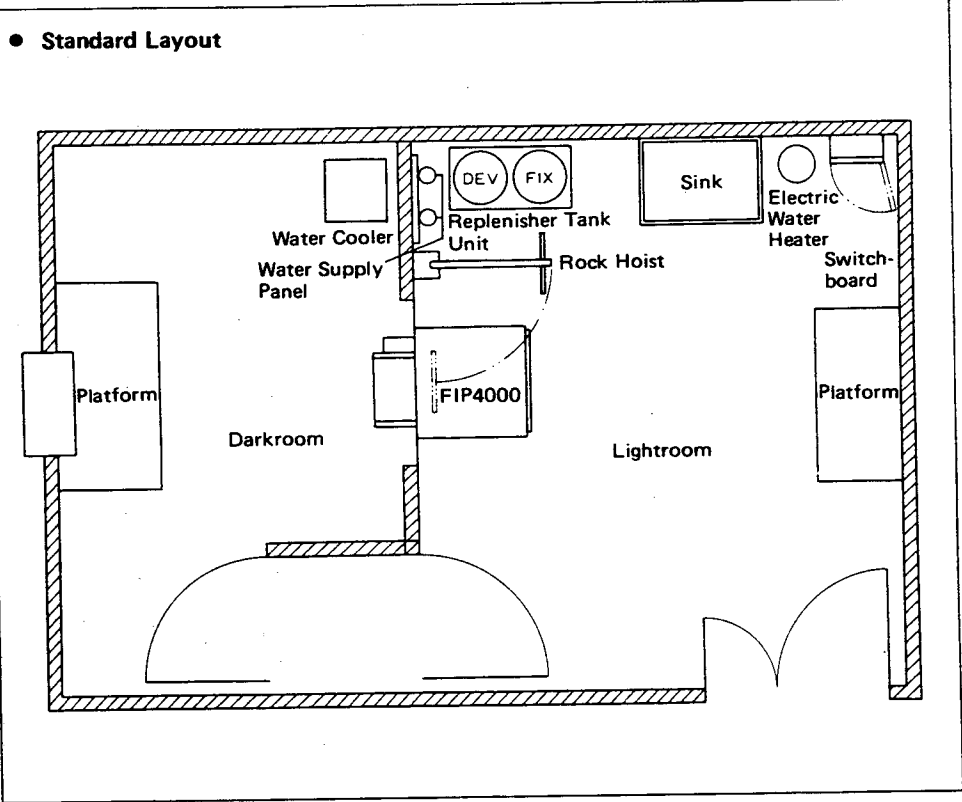

● View of Processor and Fittings Installed (Sample Layout)

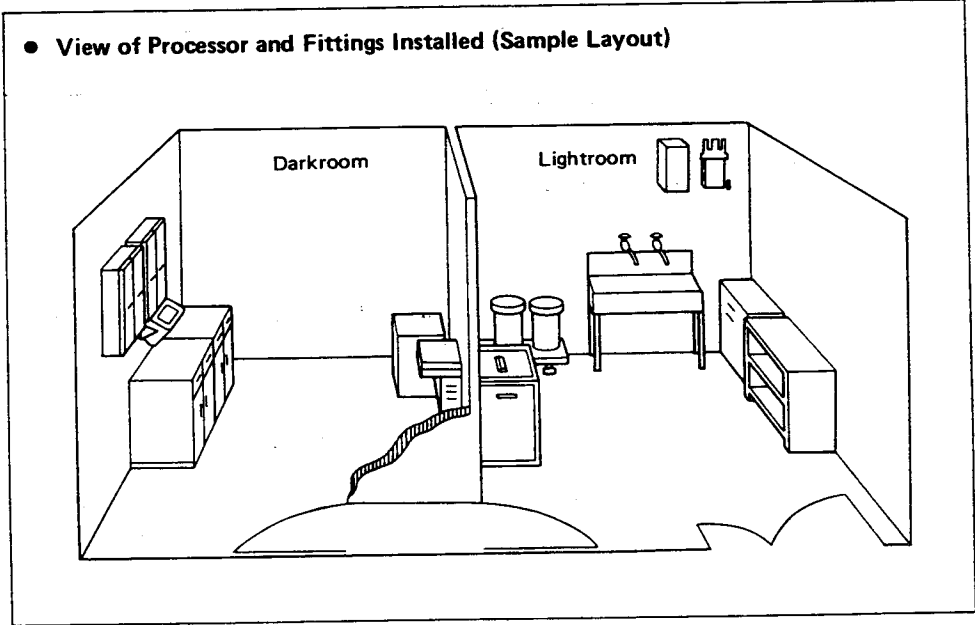

« Nonstandard Installation »

● Modified Standard Installation

This layout requires that the processor lie mainly in a dark room with the output section protruding past a partition into a lightroom. Such an arrangement is recommended when the darkroom is spacious, but the lightroom is not sufficiently spacious.

● Darkroom Installation

This layout requires that the entire processor be installed in the darkroom. Such an arrangement is recommended when the darkroom is spacious enough and there is no other suitable room in which to install the processor.

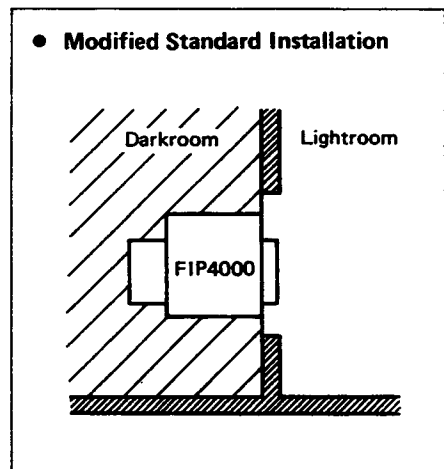

▣ WORK SPACE

A minimum clearance of 60 cm around the processor should be provided for unobstructed operation, maintenance, and servicing. When the processor is to be used in conjunction with the Fuji Automatic Feeder IX, however, a minimum of 100 cm is required from the input side.

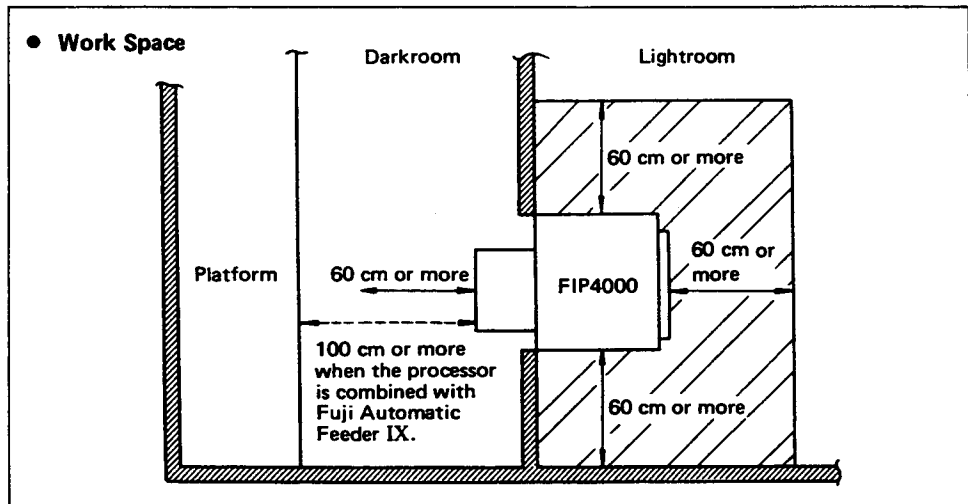

▣ DARKROOM LIGHTING

« White Light »

The white light for the darkroom, into which light from other sources is not likely to come, should be as bright as possible. The number of white light lamps, therefore, should be determined according to darkroom size.

« Safelight »

The use of safelight results in increasing the work efficiency; however, care should be exercised to prevent film fogging. It is therefore recommended that the Fuji Safelight Glass No. 5 (dark orange) be used in conjunction with a safelight lamp. This safelight glass protects films against rather intense light, thus ensuring easy and reliable operation. Safelight may be used in only the compartment where films are handled; however, it can be best used if a large safelight lamp is installed on a ceiling or at other suitable place, which results in facilitating the entire operation.

2. EXTERNAL VIEWS AND DIMENSIONS

1 FIP4000 AND ACCESSORIES

● FIP4000 External Views and Dimensions

Unit: mm

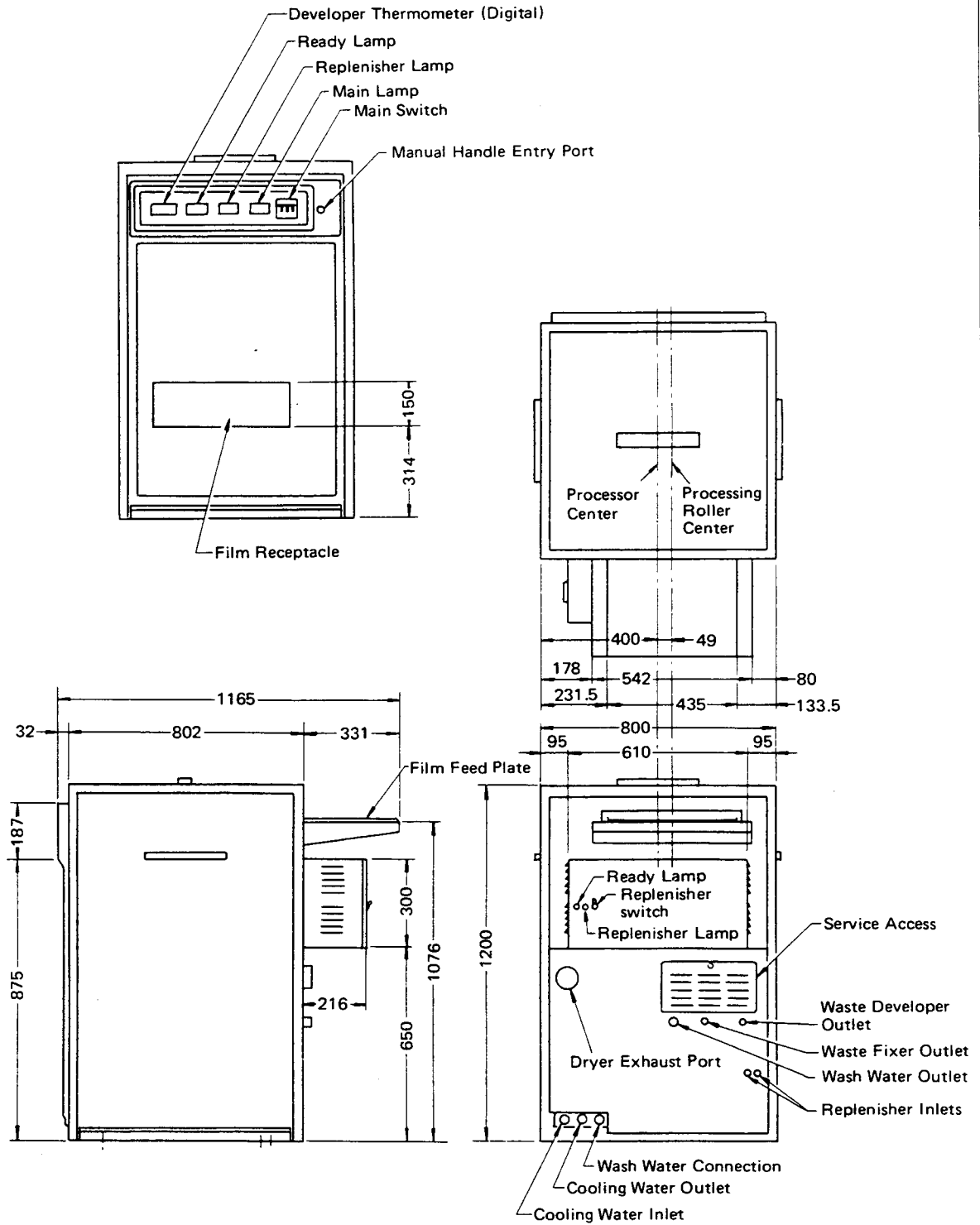

● Replenisher Tank Unit

Unit: mm

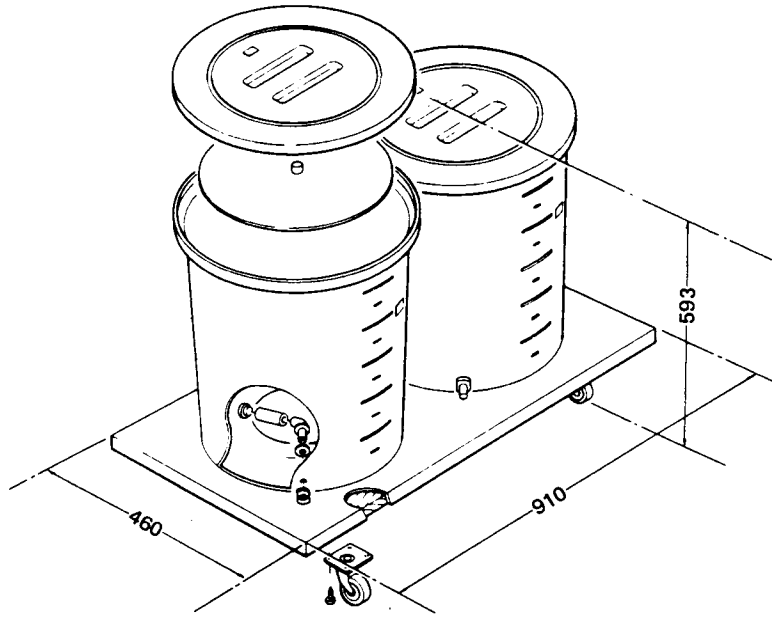

Tank Capacity: 50 lit. (both developer and fixer tanks)

● Rack Hoist

Unit: mm

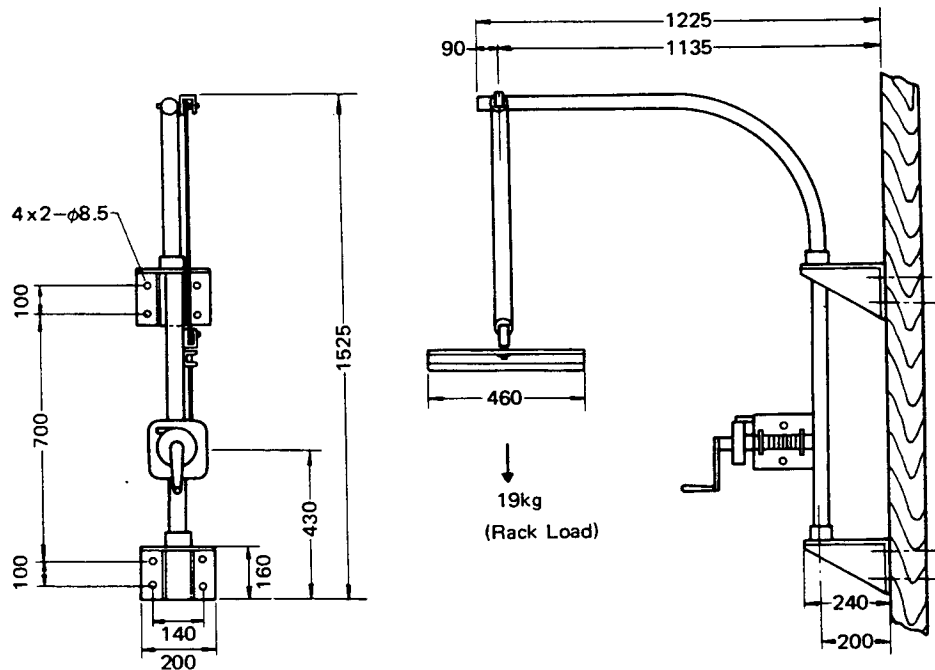

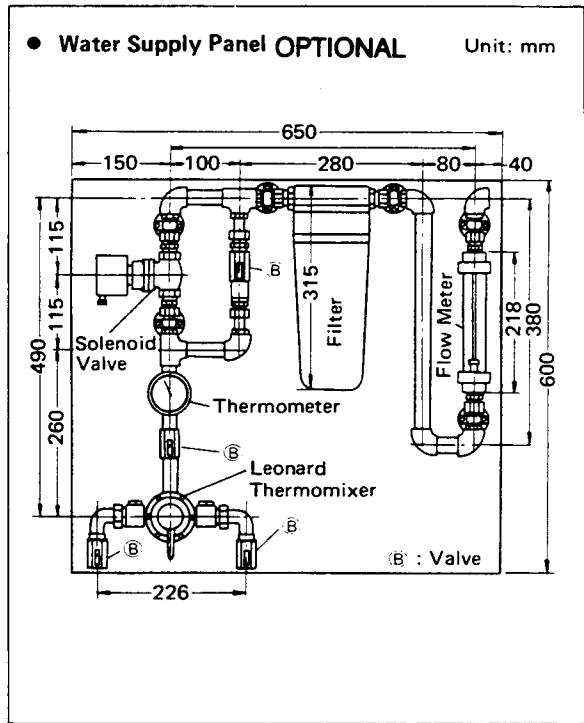

3 FUJI AUTOMATIC FEEDER IX (MOUNTED ON FIP4000) **OPTIONAL**

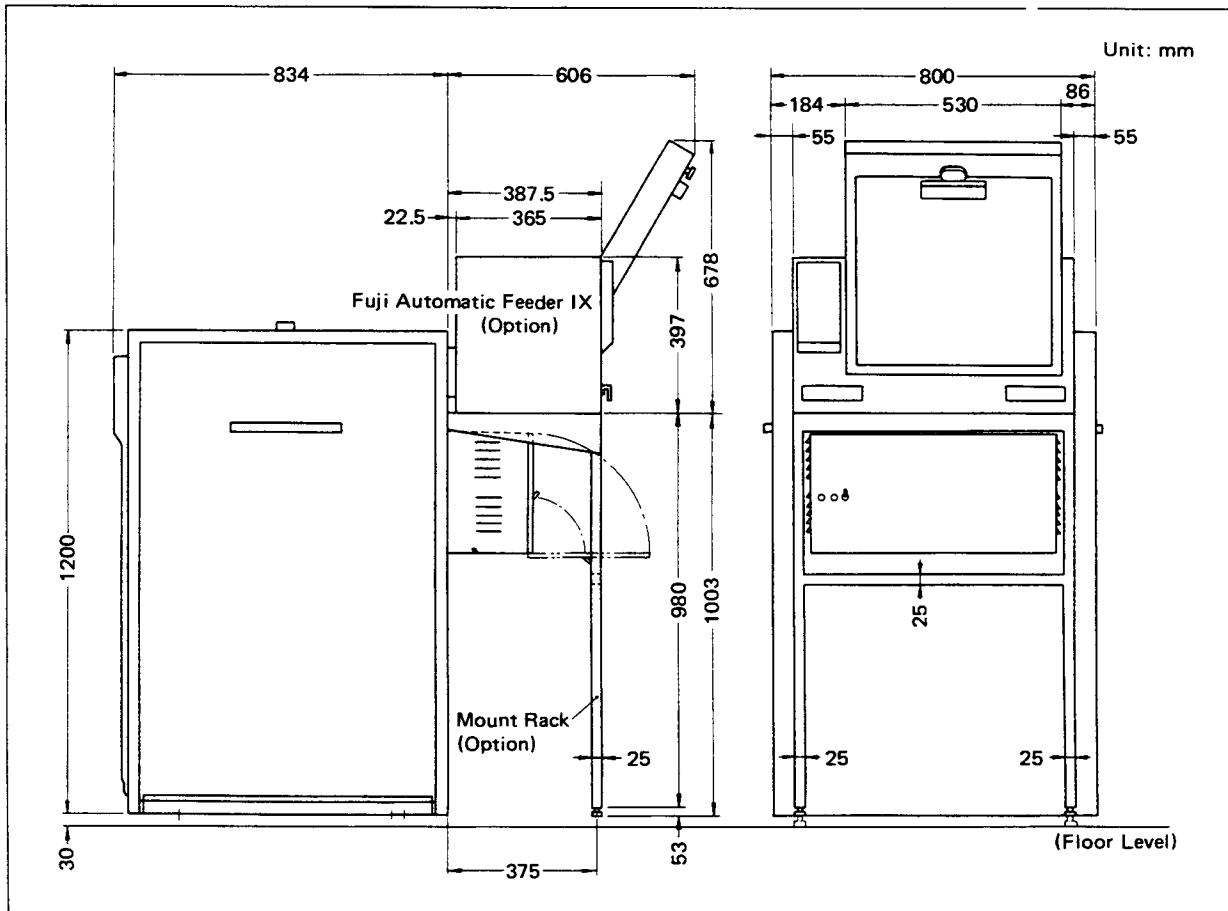

3. ENVIRONMENTAL REQUIREMENTS

1 ROOM CONDITIONS

1. A ventilator should be installed in the processor room for the following reasons.
 - ① As films are dried through the introduction of room air, drying may be faulty or insufficient if the room temperature or humidity is high.
 - ② Protection of the FIP4000 against corrosion has been given adequate consideration through the use of non-corroding materials like stainless steel. However, if processor room ventilation is inadequate or room humidity is allowed to rise beyond acceptable levels, not only will the processor life be shortened but its operation may become somewhat erratic leading to possible failure.
 - ③ The processor room will need ventilating equipment especially when the installation layout is of the darkroom type or of the modified standard type.
2. **Avoid installing the processor in a location where it is directly exposed to sunlight. If the FIP400 is exposed to direct sunlight, such may lead to unexpected problems. The processor should be installed in a location away from windows admitting direct sunlight or if such is not possible, shade the processor using a light tight curtain.**
3. Keep the processor room temperature above specified levels.

In cold climates, the solutions and water in the processor as well as in the supply and drainage systems may freeze unless provision is made to prevent such conditions. Further, if solution temperatures are allowed to fall below specified levels at night, prolonged heating may be required each morning to bring the solutions to operating temperatures.
4. Protect the processor against dust and dirt.

The FIP4000 should be installed in a room that is adequately protected against dust and dirt like grit. In general, the films that are processed with the FIP4000 are often used in locations where there are excessive amounts of dust and grit. Since such fine particles have an adverse effect on X-ray films, producing spots, streaks and scratches, it is very important that the processor room be completely protected against all sorts of dust and dirt.

2 FLOOR CONDITIONS

1. Verify that floor support is adequate.

The total weight of the FIP4000 is 370 kg, which is distributed on a floor area of 800 x 802 mm (0.62 m²). Check to ensure that adequate floor support is provided to carry this weight.
2. Waterproof the floor.

When cleaning and servicing the processor, it is inevitable that a certain amount of water and the processing solutions spatter over the floor. It is therefore essential that the floor be waterproofed.
3. **Verify that the floor drain is adequate.**

If water is often flowing on the floor or if the room floor is wet or damp, such will lead to shortening the processor life and can also be the cause of operational difficulties. Therefore it is essential that the floor be adequately drained. It is recommended that a floor drain be provided, which also results in ease of cleaning and other jobs.

4. CONSTRUCTION ESSENTIAL TO INSTALLATION

1 FOUNDATION WORK

1. Provide a floor structure that is level and strong enough to carry the weight of a fully loaded FIP4000.
2. Adequate consideration should be given to the use of materials that are acid and alkali resistant and easy to clean.

FIP4000	Bottom Area	800 x 802 mm (0.64 m ²)
	Loaded with Solutions for Operation	370 kg
	Empty	294 kg
	Knocked Down for Shipment	220 kg
Replenisher Tank Unit	Floor Area	910 x 460 mm (0.42 m ²)
	Total Weight	150 kg

2 ROOM PARTITIONING

- When the FIP4000 is to be installed across a wall between a darkroom and a light-room, an opening with a wooden frame attached should be provided.
- The dimensions of the partitions are determined so that a clearance of 30 mm is provided between floor surface and processor base. Such clearance is necessary to protect the processor against corrosion.
- Partitions used for the IX-17 can be reused for FIP4000 without any modification.
- As for the dimensions of the partitions used for non-standard installation, consult your Fuji Film technical representative.

◀ Standard Installation ▶

● Standard Installation (Opening and Wooden Frame Dimensions)

Unit: mm

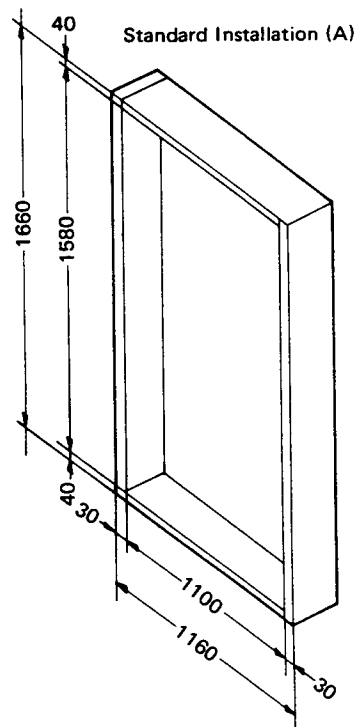
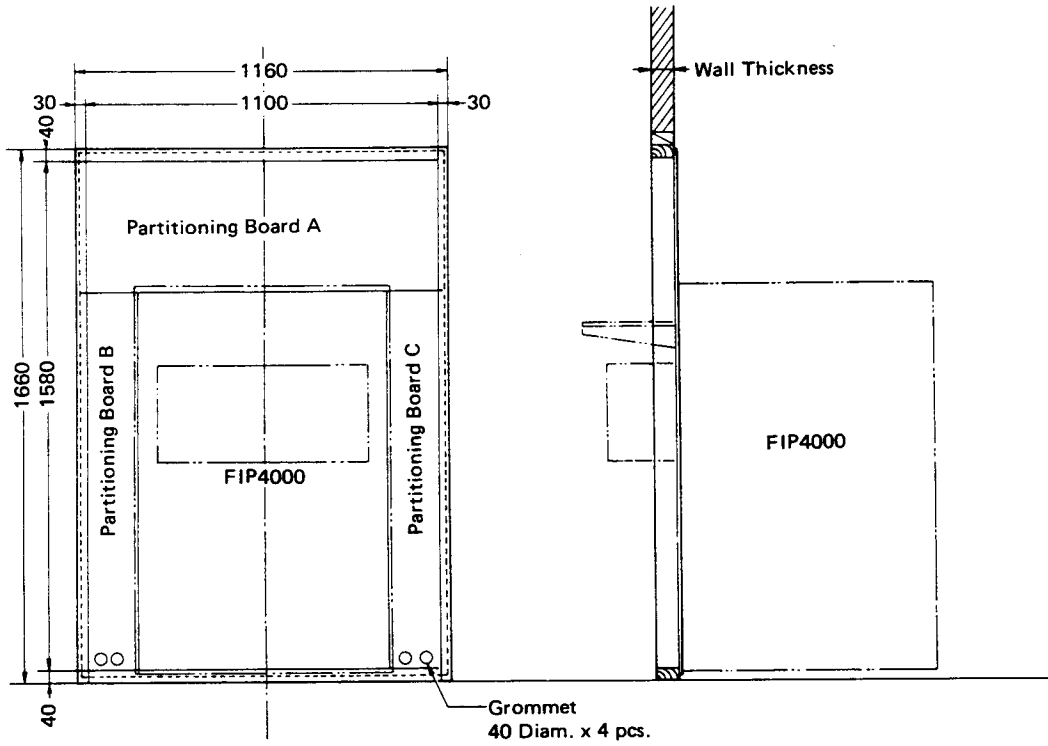

Partitioning Board
Type B
Mount Rack Not Provided

- **Mount Rack**

A mount rack shown below should be used when floor strength is inadequate or the floor surface is not even.

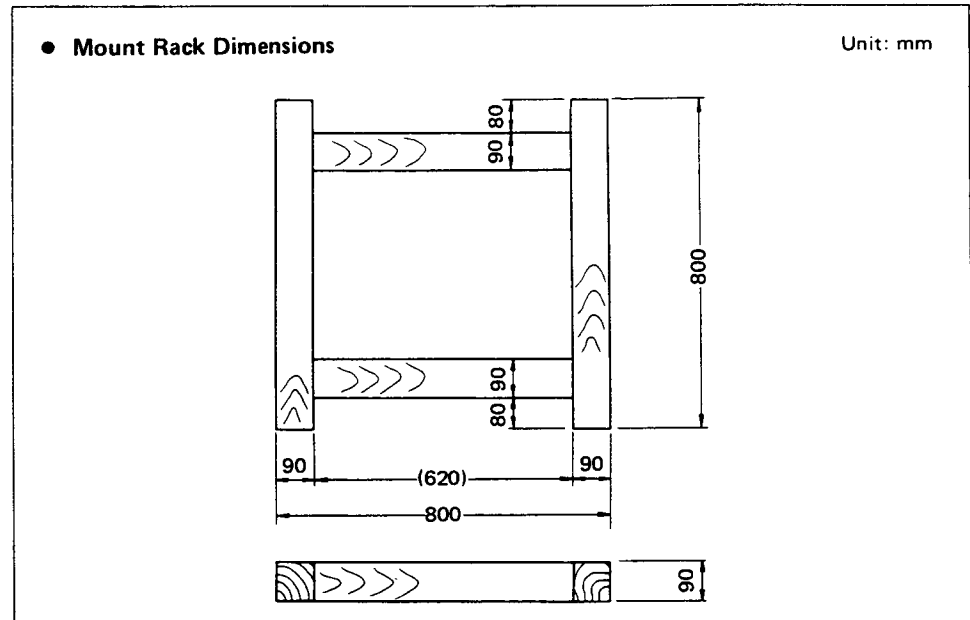

3 PLUMBING

« Water Supply Conditions »

Water Flow Rate : 10 lit./min. during processing; 1 to 3 lit./min. during standby.

Water Temperature : 31°C (87.8°F)

« Plumbing Work »

1. Plumbing work on FIP4000 and its complementary equipment should be performed in accordance with the Plumbing Diagram.
2. It is recommended that the Water Supply Panel, furnished as an option, be installed because it will facilitate supply plumbing work. (The Water Supply Panel incorporates a mixing valve, thermometer, solenoid valve, filter, flow meter, and bypass circuit.)
3. Where the quality of water is not good enough or the supply plumbing contains iron rust or other foreign matter, a filter should be installed at each inlet of water heater and water panel.
4. Water of 31°C (87.8°F) or more should be supplied at a flow rate of 10 liters per minute. If any suitable water supply facilities are not on hand, warm water is supplied only briefly, or the amount of warm water supplied is insufficient, the Electric Water Heater (option) should be used.
5. To ensure stable operation of the mixing valve and to maintain the wash water temperature at a fixed level, cold water should be cooler than wash water by 3°C (5.4°F) or more and warm water warmer than wash water by 15°C (27°F) or more. Further, both cool and warm water should be supplied under a pressure of 0.5 kg/cm² or more. The smaller the difference in pressure between cool and warm water, the more stable is the wash water temperature.
6. Cooling water is required for maintaining developer and fixer temperatures at fixed levels. The temperature of cooling water should be lower than that of developer by 5°C (9°F) or more.
7. In case of water cooler failure, it is necessary to provide a cooling bypass circuit that cools the developer with tap water.

4 PLUMBING DIAGRAM

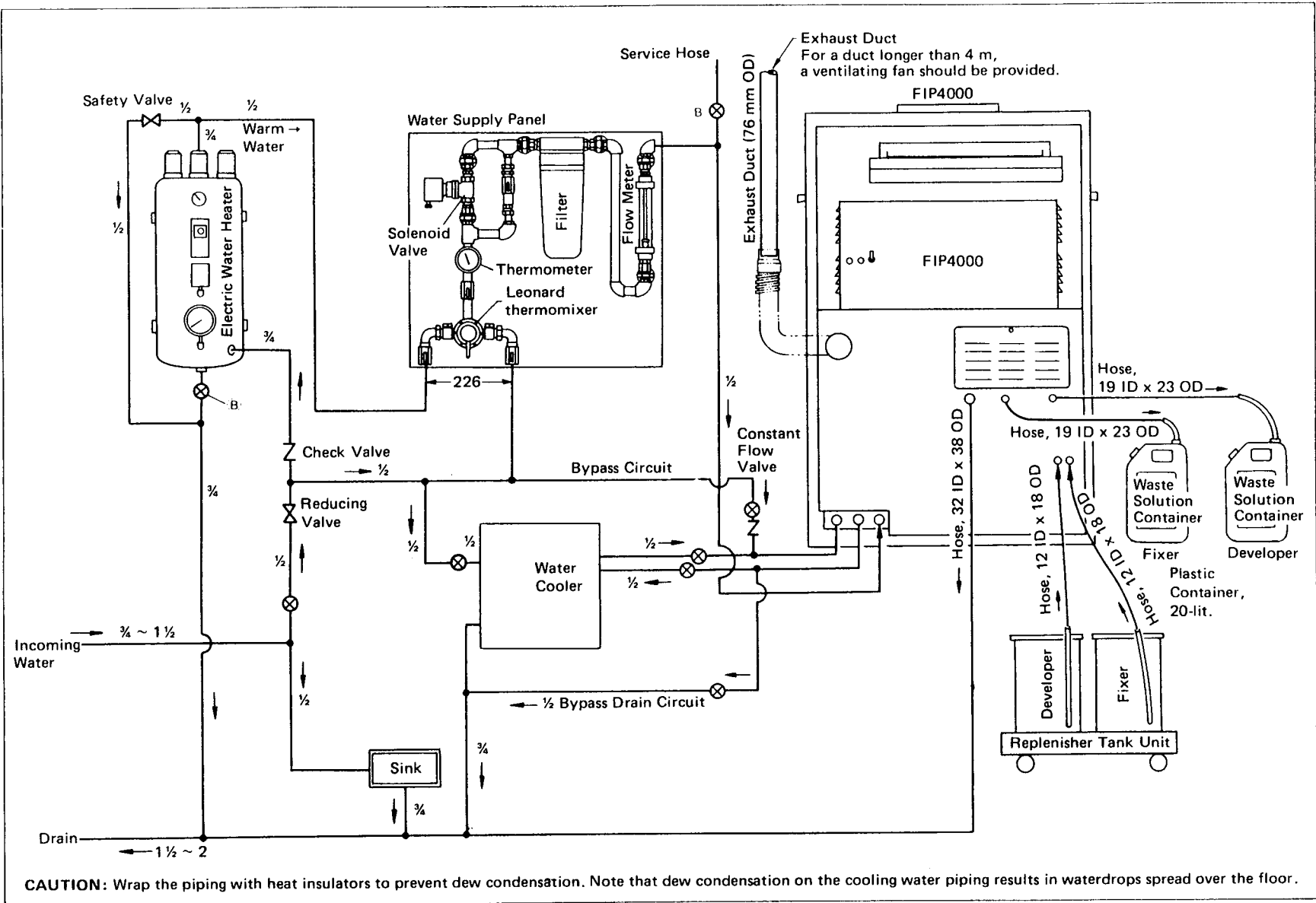

5 DRAINAGE

« Waste Water Conditions »

Waste Water Flow Rate: 15 or less lit./min. during processing; 40 lit./min. during tank draining (3 tanks drained together).

« Drainage Work »

1. Using a hose connect the FIP4000 wash water drain to the floor drainage.
2. It would be very useful if provision is made such that the developer and fixer drain hoses can be connected to the floor drainage, thereby facilitating draining after tank cleaning or other jobs.

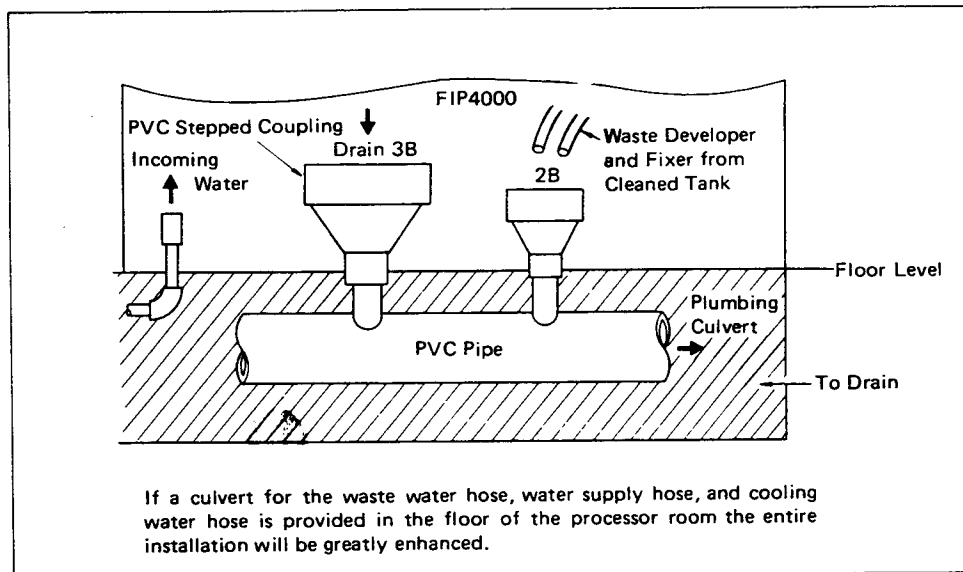

3. Since the drain opening is not closed up, provision should be made for trapping sewer gas and odors.

« Waste Solution and Waste Water »

Waste developer and fixer should not be discharged into the sewerage but collected in the container. The first tank washing should be collected in the container, although the other washings may be discharged into the sewerage.

6 ELECTRICAL WORK

« Electrical Power Supply Conditions »

- | | |
|-----------------------------|--|
| ① Power Requirements | 200 V AC, 50/60 Hz |
| ② Voltage Regulation | Within $\pm 10\%$ of 200 V |
| ③ Maximum Power Consumption | 5.5 kVA when the FIP4000 is operated alone |

« Electrical Work »

1. Power requirements of FIP4000 and its complementary equipment are as follows.
FIP4000 : 200 to 240 VAC, single-phase, 60 Hz, 30 AMP service
2. Do not fail to ground the processor using a Class 3 ground. Note that the primary wiring should be 200 V, single-phase, 100A wires.

7 RACK HOIST INSTALLATION

1. Install the rack hoist to the right or left of the FIP4000.
2. The partition wall is required to be strong enough to support the rack hoist. The load applied to the partition wall is as shown below.

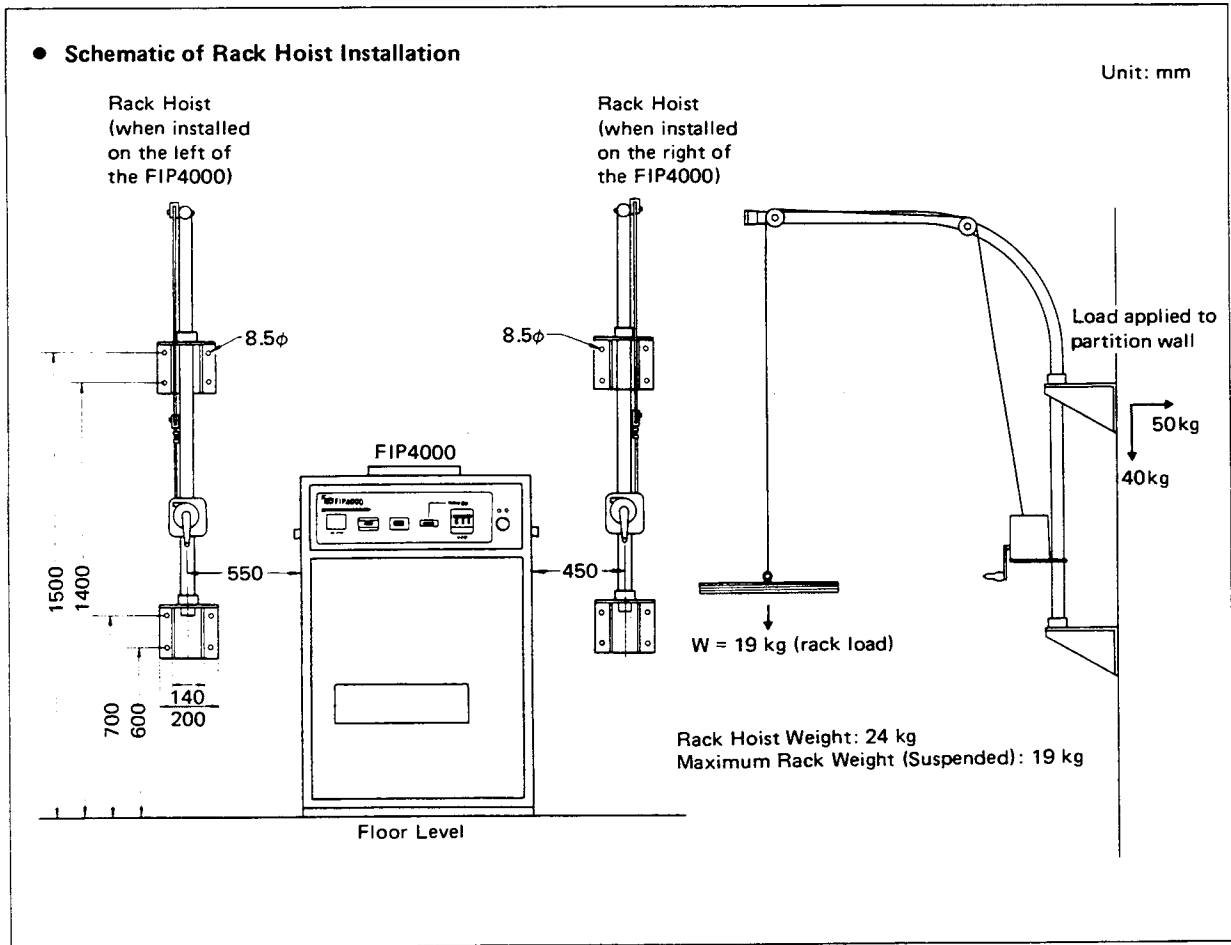

3. Use M8 bolts to fasten the rack hoist to the partition wall.

8 EXHAUST DUCT WORK

1. Run an exhaust duct from the FIP4000 dryer exhaust port to the outside.
2. Note that the FIP4000 exhaust connection is 76 mm in diameter.
3. Use a PVC pipe as the exhaust duct.
Avoid bending the pipe in a sharp angle even when it must be bent.
4. If an exhaust duct longer than 4 m is required, install a ventilating fan.
5. If the exhaust duct is connected to an existing ductwork, inadequate ventilation or backflow may result, thus disturbing the proper drying of the films. Therefore, be sure to run the exhaust duct to the outside.
6. When an automatic feeder is used in conjunction with the processor, see that the air pressure in the darkroom is higher than in the lightroom.

9 PROCESSOR TRANSFER ROUTE

Be sure there are adequate doorways or other openings to bring the processor to its installation site, and remove all obstructions in the way.

Note that the FIP4000 is 80 cm wide and 116.5 cm long when unpacked, and 110 cm wide, 190 cm long and 139 cm high when crated for shipment.

5. INCIDENTAL WORK

1 SINK

In the processor room a sink will be needed for processor maintenance, cleaning, and solution preparation.

1. Install a sink in the processor room when possible and as near the processor as possible.
2. The sink should measure at least 600 mm by 500 mm and be 200 mm or more deep so that the racks can be cleaned in it.

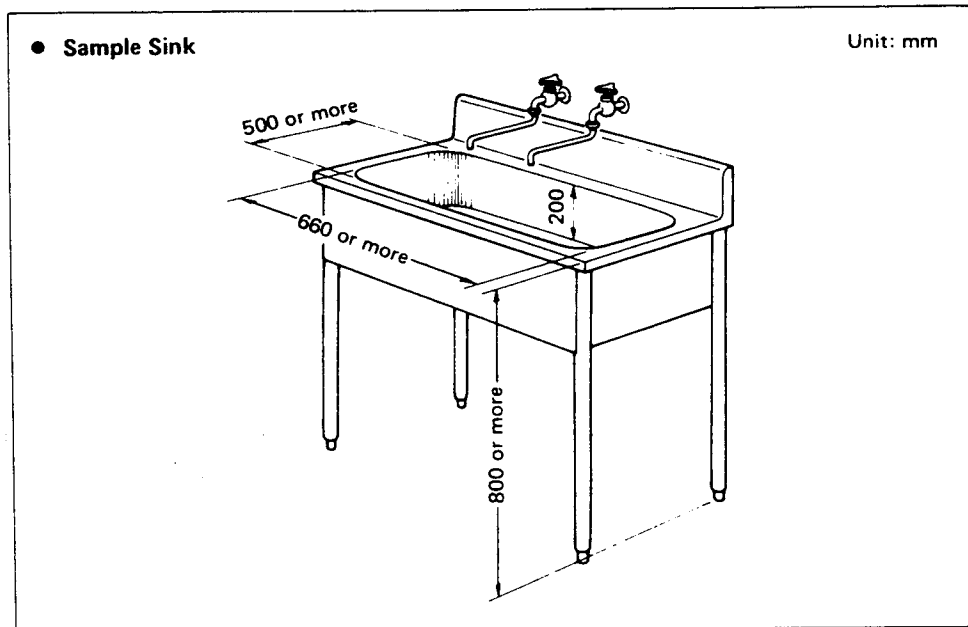

6. DATA REQUIRED FOR INSTALLATION

1 ELECTRICAL SYSTEM

① Power Requirements	200 to 240 VAC, single-phase, 60 Hz
② Voltage Regulation	Within $\pm 10\%$ of 200 V
③ Maximum Power Consumption	17 A
④ Grounding	Class 3 ground
⑤ Main Electrical Parts	200-V 40-W motor x 1 (drive) 200-V 45-W motor x 2 (circulation pump) 200-V 400-W motor x 1 (dryer fan) 200-V 3.5-W motor x 1 (replenisher pump) 200-V 750-W heater x 3 (dryer) 200-V 1000-W heater x 2 (developer, fixer)

2 VENTILATION SYSTEM

Heat Release	During operation : 170 kcal/hr. During standby : 150 kcal/hr.
--------------	--

3 WATER SUPPLY AND DRAINAGE SYSTEM

① Water Supply Flow Rate	During operation : 10 lit. or more/min.
② Supplied Water Temperature	31°C (87.8°F)
③ Drainage Flow Rate	During operation : 15 lit. or less/min. During tank draining: 40 lit. or less/min.

4 PROCESSOR AND TANK WEIGHTS

① FIP4000	Bottom Area	800 x 802 mm (0.64 m ²)
	Weight:	
	Loaded with solutions for operation	370 kg
	Empty	294 kg
	Knocked down for shipment	220 kg
② Replenisher Tank Unit	Floor Area	460 x 910 mm (0.42 m ²)
	Total Weight (loaded)	150 kg

5 SAFELIGHT

Safelight Glass	Fuji Safelight Glass SLG No. 5
-----------------	--------------------------------

7. CONNECTOR PORT DIMENSIONAL DIAGRAM

Unit: mm

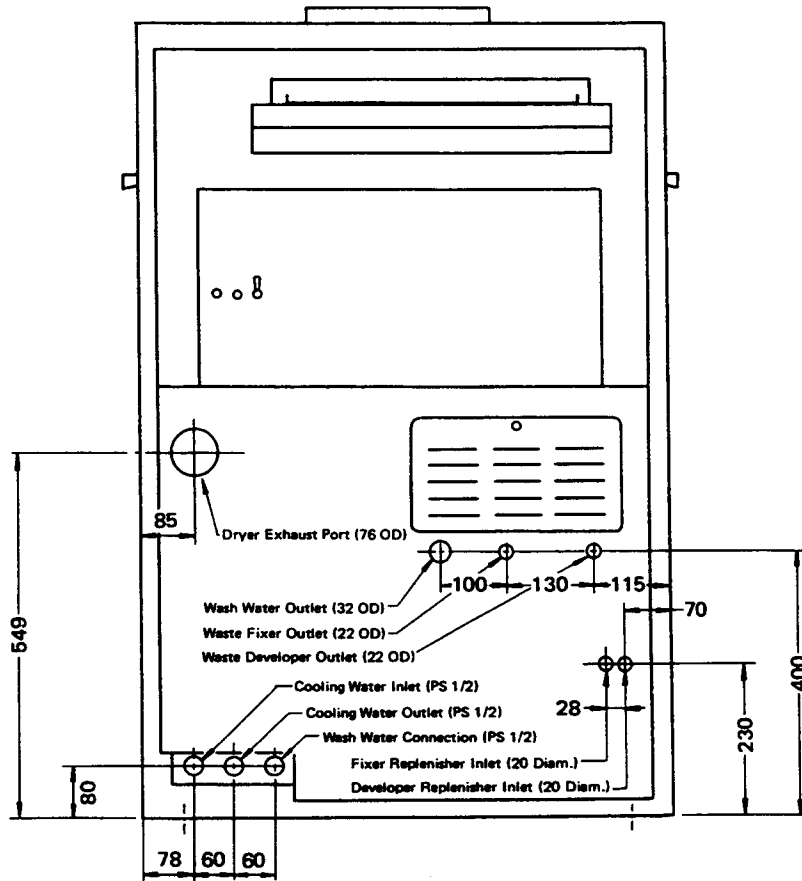

8. SECTIONAL NOMENCLATURE

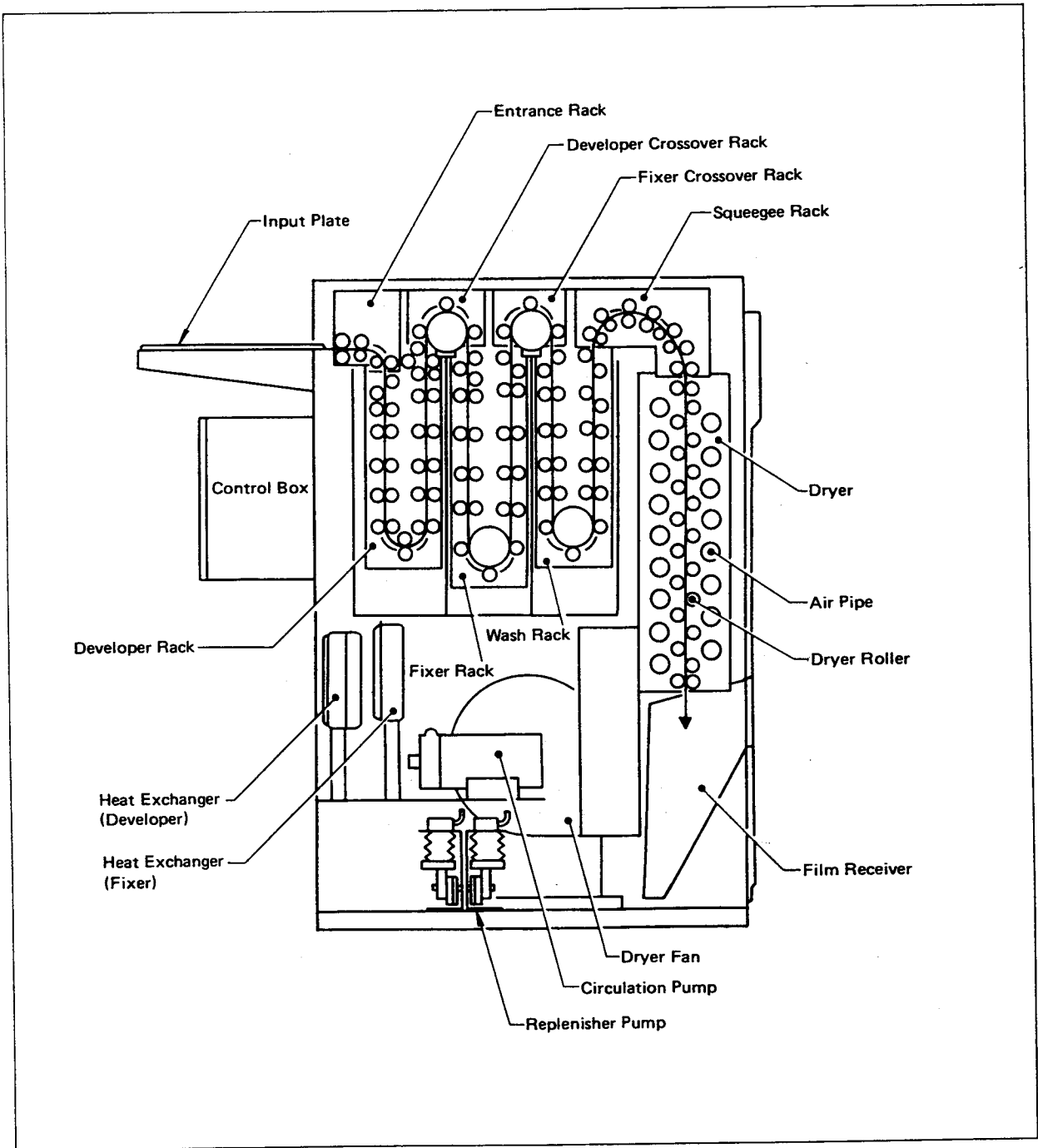

9. ELECTRICAL CIRCUIT DIAGRAM

