

 **FUJIFILM**

SERVICE MANUAL

INDUSTRIAL X-RAY FILM PROCESSOR

FIP7000

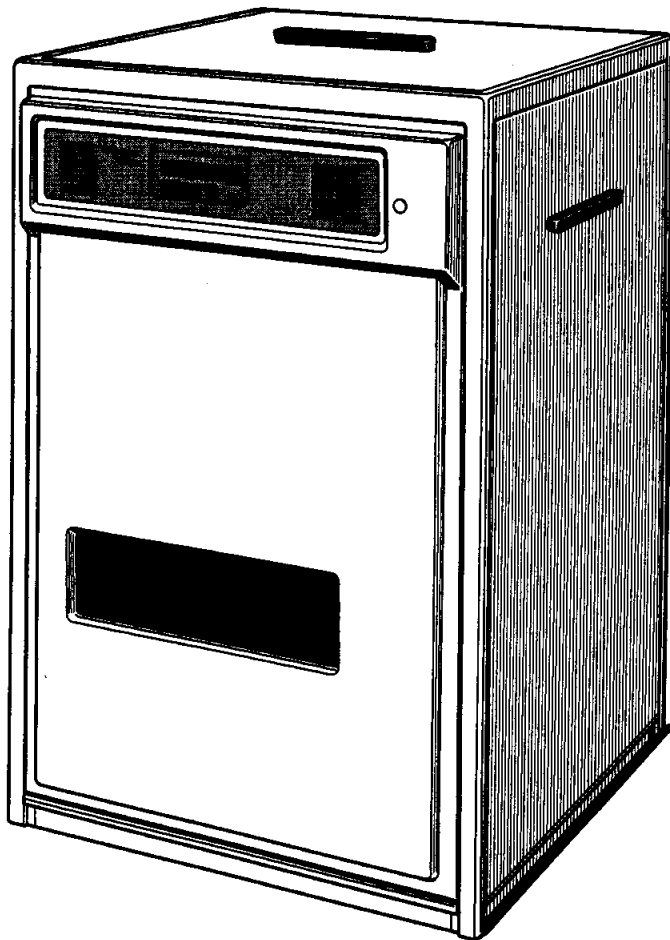

First Edition

IX-70-SAE

INTRODUCTION

The FIP7000, Fuji Industrial Film Processor, features:

- Computer-control user friendly built-in programs including self-diagnosis.
- Multi processing cycle, 5'28"(60sec Developer Immersion Time)/10'52"(120sec Developer Immersion Time)
- Integrated frame and tanks
- Low noise, low exhaust system

SAFETY

This section describes the precautions to be observed in assuring safe FIP7000 servicing. Before servicing FIP7000, carefully read and thoroughly understand the precautions set forth in this section. The safety precautions are classified into **WARNING** and **CAUTION** categories. These two categories are defined as follows.

WARNING

WARNING indicates a potentially hazardous situation which, if not avoided, could result in death or serious injury.

CAUTION

CAUTION indicates a potentially hazardous situation which, if not avoided, may result in minor or moderate injury. It may also be used to alert against unsafe practices and property-damage-only accidents.

Basic Servicing Precautions

WARNING

DANGEROUS VOLTAGE

Some parts in the power supply box and other sections operate on 200V-240V. When checking parts of making voltage measurements with the power ON, use utmost caution not to touch any high-voltage line.

WARNING

DISCONNECT THE MAIN POWER

When replacing internal parts or making adjustments, be sure to turn OFF the MAIN switch (circuit breaker).

CAUTION

ELECTROSTATIC DISCHARGE

This equipment includes parts and assemblies sensitive to damage from electrostatic discharge. Use caution to prevent damage during all service procedures.

WARNING

PERSONAL INJURY

Do not wear a necktie, a necklace, or other accessories that may get caught in movable sections.

CAUTION

PERSONAL INJURY

Do not attempt to lift heavy unit alone.
To avoid straining your back, lift with an assistant.

Contents FIP7000 Mechanical Service Manual

Specifications	4
1. Sectional Nomenclature	5
2. Roller And Guide Plate Arrangements	6
3. Gear Specifications And Arrangements	8
4. Arrangements And Specifications of Sprocket And Tension Pulley	12
5. Bearing Arrangements And Specifications	14
6. Spring Arrangements And Specifications	16
7. Circulation System Diagram	18
8. Mechanical Data	19
(1) Line Speed (2) Processing Speed (3) Processing Steps	
(4) Rack Weights (5) Drain Time	
9. Adjustment	21
[1] Rack	
(1) Rack Distortion (2) Chain Alignment (3) Labber Chain Tension	
(4) Turn Guide Plate	
[2] Chemicals Circulation Line	
(1) Chemical Level (2) Chemical Tank	
[3] Feed Tray	
[4] Drive	
[5]-1 Worm Gears	
[5]-2 Drive Shaft Thrusting Direction Play	
10. Removing The Side Panel	27

Specifications

Type	Continuous roller transport system
Processing Time	5 minutes and 11 minutes from developing to drying
Film Processed	Max Width : 43.2cm Min length : 15.2cm
Processing Capacity	Simultaneous feeding in 4rows (8.9cm width) 5-min processing : 450 sheets/hour (8.9x25.4cm) 11-min processing : 225 sheets/hour (8.9x25.4cm)
Tank Volumes	Developer : 30 ℓ Fixer : 24 ℓ Wash : 22.5 ℓ
Water Temperature	31°C (87.8°F)
Wash Water Flow Rate	10 ℓ /min (Only while processing)
Temperature Control Systems	Developer : Automatic temperature control by means of a heat exchanger (1000W heater/cooling water and a thermistor) Fixer : Automatic temperature control by means of a heat exchanger (1000W heater/cooling water and a thermistor) Wash Water : Specified temperature is maintained by means of a mixing valve
Circulation Systems	Continuous circulation provided to both the developer and fixer through circulation pumps
Replenishment Systems	A filter package is assembled in the developer circulation line to maintain developer quality When films are fed, replenishment pumps are turned on due to signals from the photosensors at the film entrance section
Materials	High quality stainless steel and specially composed resins
Dimensions	Length 802mm (1165 mm including feeding table and dryer cover) Width 800mm Height 1200mm
Weight	302kg with out solutions 378kg with solutions
Power Requirements	1-phase, 2-Wire AC200/208/220/230/240V, 50/60 Hz 30A
Optional accessories	Autofeeder IX Autofeeder support

1. Sectional Nomenclature

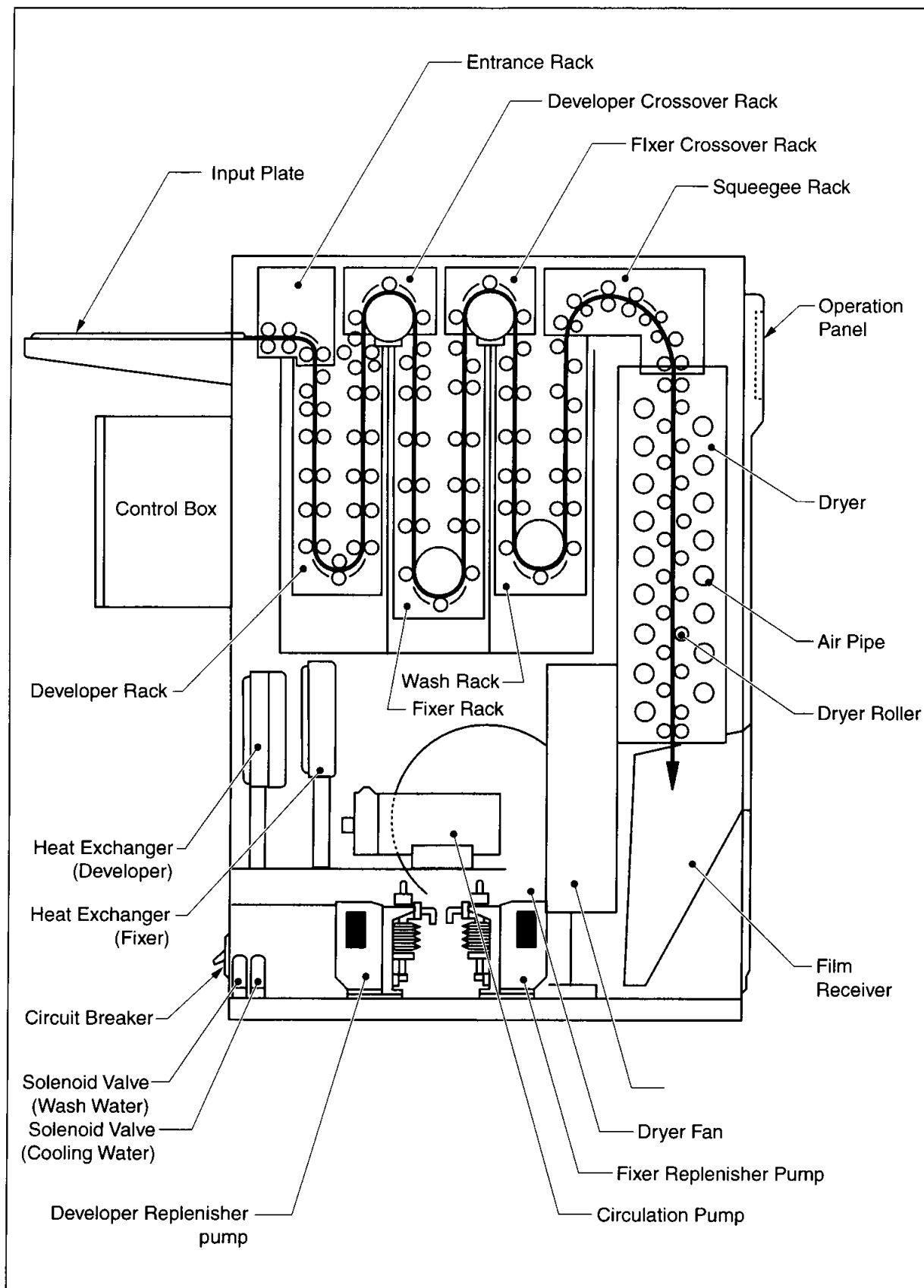

● Roller Specifications

No	Part No		Material	Diameter	Length	Color	Q'ty	Assembly
1	334F2272C		Phenol Resin	75mm	547mm	Brown	2	FIX, WASH Rack
3	334F2275C		Phenol Resin	75	516	Brown	2	FIX Cross/Rack
4	334F2273		Acryl	25	547	Black	9	DEV, WASH Rack
5	334F2252		Phenol Resin	25	547	Brown	11	DEV Rack
6	334F3099A		EPT Rubber	25	547	Black	12	DEV Rack
7	334F3103		EPT Rubber	20	547	Black	1	DEV Rack
8	334F2251		Phenol Resin	25	547	Brown	41	FIX, WASH Rack
9	334F5013		Capron/ Phenol Resin	21 +α	551.5	Dark Brown	1	WASH Rack
10	334F5014		Capron/ Phenol Resin	21 +α	540	Dark Brown	1	WASH Rack
11	334F2277		Phenol Resin	25	601	Brown	1	Entrance Rack
12	334F2276		Phenol Resin	25	499	Brown	17	Entrance, DEV Cross FIX Cross, Squeegee
13	334F2274		Phenol Resin	20	499	Brown	5	Entrance, Squeegee
15	334F3102		EPT Rubber	20	499	Black	1	Squeegee Rack
16	334F8617160		Phenol Resin	25	553	Brown	21	Dryer Section
17	334F2885		Phenol Resin	24	499	Brown	1	Squeegee Rack

● Guide Plate Specifications

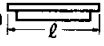
SYMB	Part No	Angle 	Length 	Q'ty	Assembly
a	363F0571A	R R31, θ 66°, a 34.8mm	l 475mm	1	Entrance Rack
b	363F0572A	R40, 65, 43.8	475	8	FIX, WASH FIX Cross Rack
c	363F0573A	R54, 27, 25.6	473	1	Squeegee Rack
d	363F0574A	R54, 39, 36.5	473	1	Squeegee Rack
e	363F0678	R40, 70, 45.9	475	2	DEV Cross Rack
f	363F2268A		475	2	DEV Rack

3. Gear Specifications And Arrangements

- Gear Arrangements at freewheel side

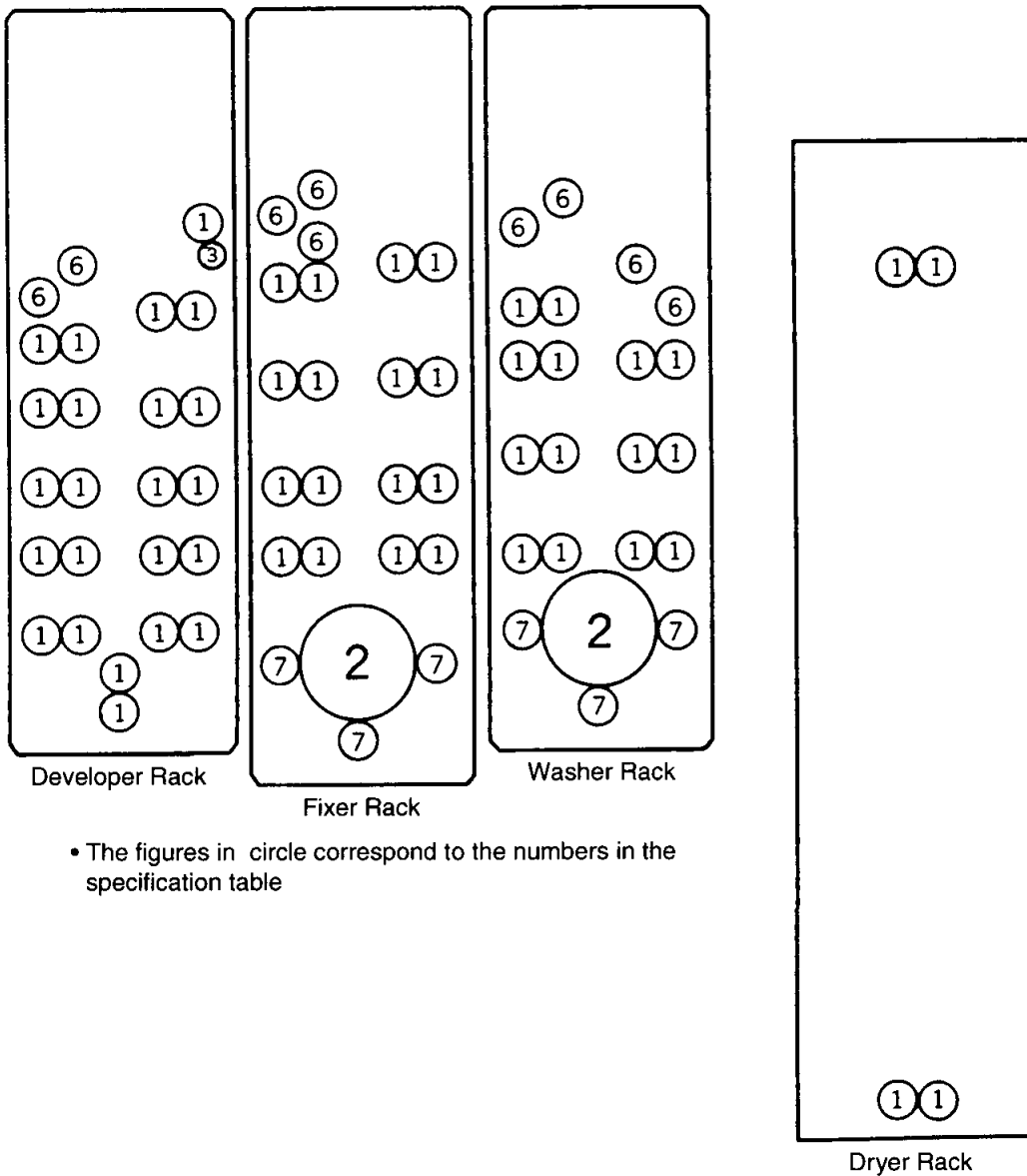
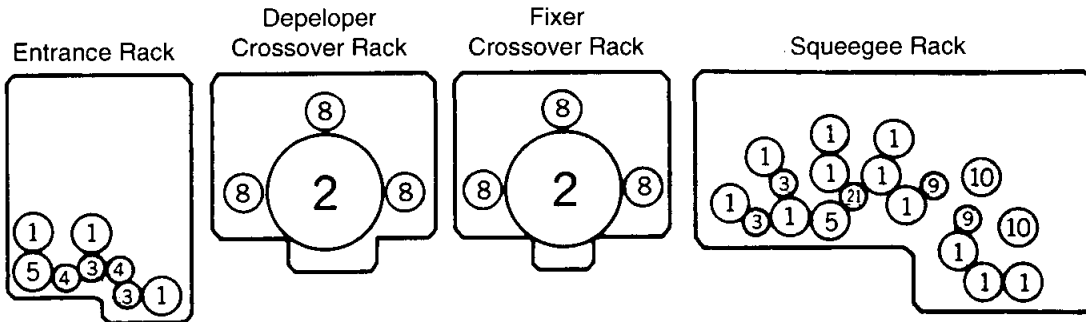

• The figures in circle correspond to the numbers in the specification table

• Gear Arrangements at drive shaft side

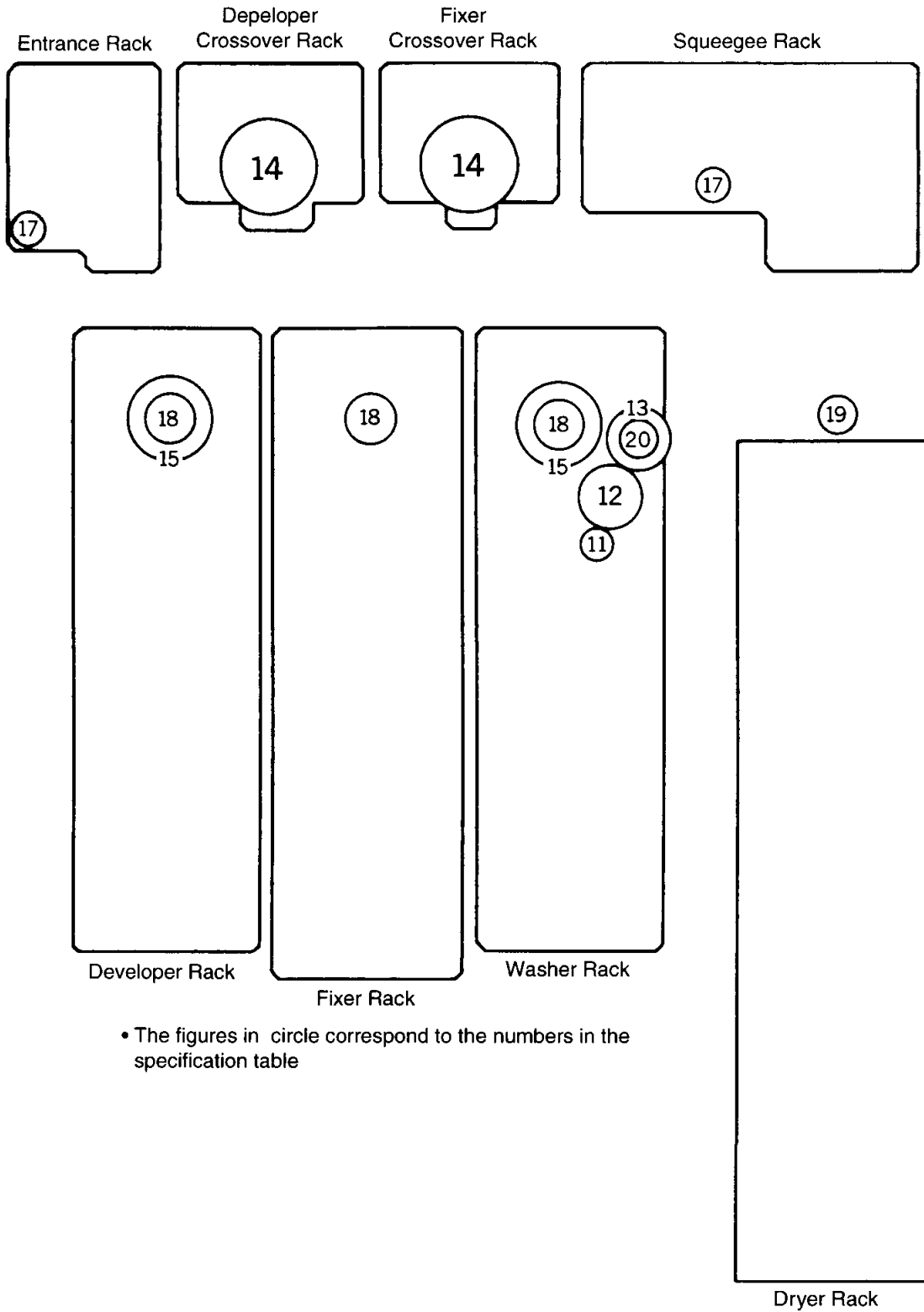

• The figures in circle correspond to the numbers in the specification table

• Gear Specifications

No	Part No			Tooth	Materials	Color	Q'ty	Component Locations	Hub-Ring
1	327F1122006			20	PBT	White	71	DEV, FIX, WASH, Entrance Squeegee Dryer	A
2	327F1126001			60	Glass Nylon	Gray	4	DEV, FIX, DEV Cross FIX Cross	B
3	327F1121601			16	PBT	White	6	DEV, Entrance Squeegee	A
4	327F1121603			16	PBT	White	2	Entrance	-
5	327F1122013			20	MC Nylon	Black	2	Entrance, Squeegee	A
6	327F1122401			24	PBT	White	9	DEV, FIX, WASH	A
7	327F8614142			20	Glass Nylon	Gray	6	FIX, WASH	A
8	327F8613321			20	Glass Nylon	Gray	6	DEV Cross, FIX Cross	A
9	327F8613542			16 16	SUS	-	2	Squeegee	-
10	327F8613541			20	Glass Nylon	White	2	Squeegee	A
11	327F1122014			20	Nylon	White	1	WASH	A
12	327F1123801			38	Nylon	White	1	WASH	-
13	327F1123202			32	Nylon	White	1	WASH	-
14	327F1127201			72	Glass Nylon	Gray	2	DEV Cross, FIX Cross	B
15	327F1126002			60	SUS	-	2	DEV, WASH	-
17	327F5151803			18	MC Nylon	Black	2	Entrance, Squeegee	B
18	327F5154501			45	MC Nylon	Black	3	DEV, FIX, WASH	C
19	327F5153601			36	MC Nylon	Black	1	Dryer	C
20	327F2151311			13	Nylon	White	1	WASH	-
21	327F1121638			16	Glass Nylon	Gray	1	Squeegee	-

● Hub-Ring Specifications

Mark	A	B	C
Part No	338F8614182	338F1015	338F8614184
Q'ty	103	8	4
Dimensions			

4. Arrangements And Specifications of Sprocket And Tension Pulley

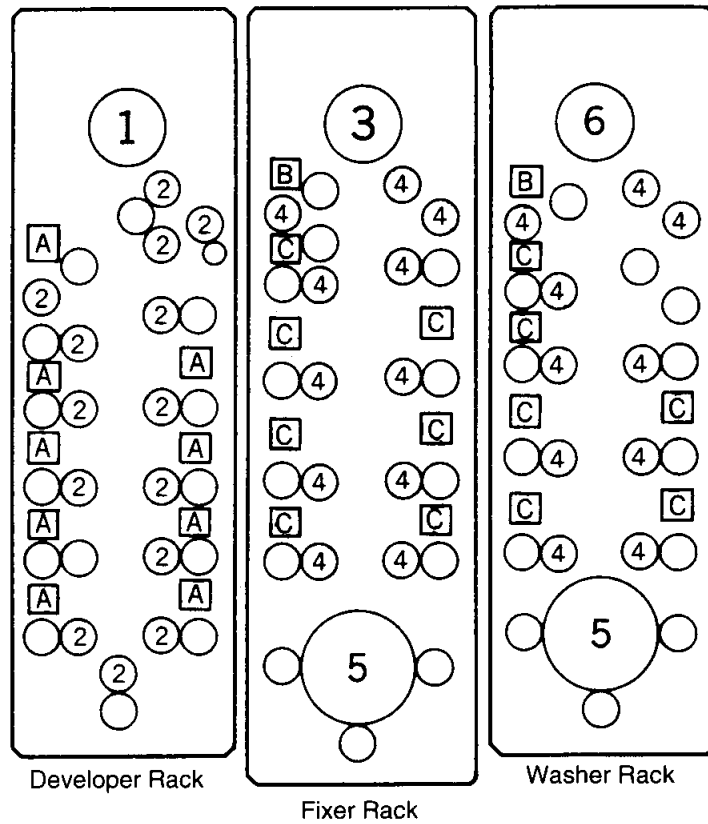

● Sprocket Specifications

No	Part No	Chain				Q'ty	Assembly
1	326F2015501	RS11				1	DEV
2	326F2012201	RS11				15	DEV
3	326F1013005	RS25				1	FIX
4	326F1011211	SR25				21	FIX, WASH
5	326F1013604	RS25				2	FIX, WASH
6	326F1013004	SR25				1	WASH

• Tension Pulley Specifications

Mark	Part No	Dimensions	Q'ty	Assembly
A	338F0149	<p>Technical drawing of pulley A showing dimensions: 11, 7, 11, 14.8, 18.</p>	9	DEV
B	362F0234	<p>Technical drawing of pulley B showing dimensions: 12, 10.5, 7, 12, 16, 8.9.</p>	1 1	FIX WASH
C	338F0150	<p>Technical drawing of pulley C showing dimensions: 7, 12, 15, 12.5.</p>	7 6	FIX WASH

● Bearing Specifications

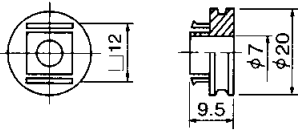
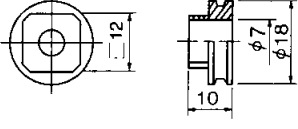
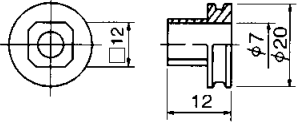
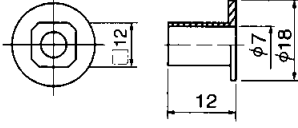
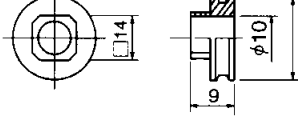
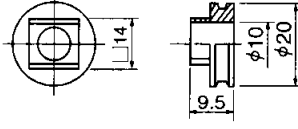
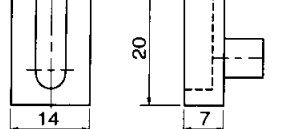
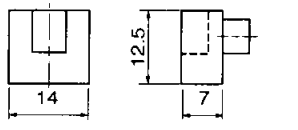
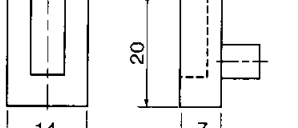
Mark	Part No	Dimensions	Q'ty	Assembly	Materials	Color
1	322FC049		10 40 38 34 6 6 28	Entrance DEV FIX WASH DEV Cross FIX Cross Squeegee	Nylon	Black
2	322FC091		12 10 8 6	DEV FIX WASH DEV Cross	Glass Nylon	White
3	322FC094		6	DEV		
4	322FC093		4	WASH	Glass Nylon	White
5	322FC092		2 2 2 2 2 2 2	DEV FIX WASH Entrance DEV Cross FIX Cross Squeegee	Glass Nylon	White
6	322FC050		2 2	FIX WASH	Nylon	Black
7	362F8319429		4	DRYER		Black
8	362F8317211		34	DRYER		Black
9	362F8317212		4	DRYER		Black

● Spring Specifications

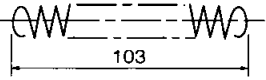
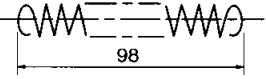
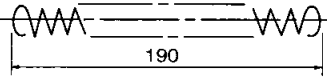
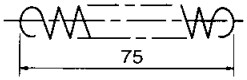
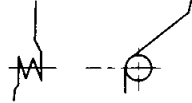
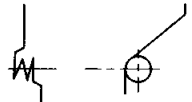
Mark	Part No	Dimensions	Q'ty	Assembly
A	388F2069		16	DEV
B	388F2073		4 16 14 6 10	DEV FIX WASH Entrance Squeegee
C	388F2072		2 2 2 2	FIX WASH DEV Cross FIX Cross
D	388F8234413		4	DRYER
E	388F3046		3 1 1 1 1	DEV FIX WASH DEV Cross FIX Cross
F	388F3045		3 1 1 1 1	DEV FIX WASH DEV Cross FIX Cross

7. Circulation System Diagram

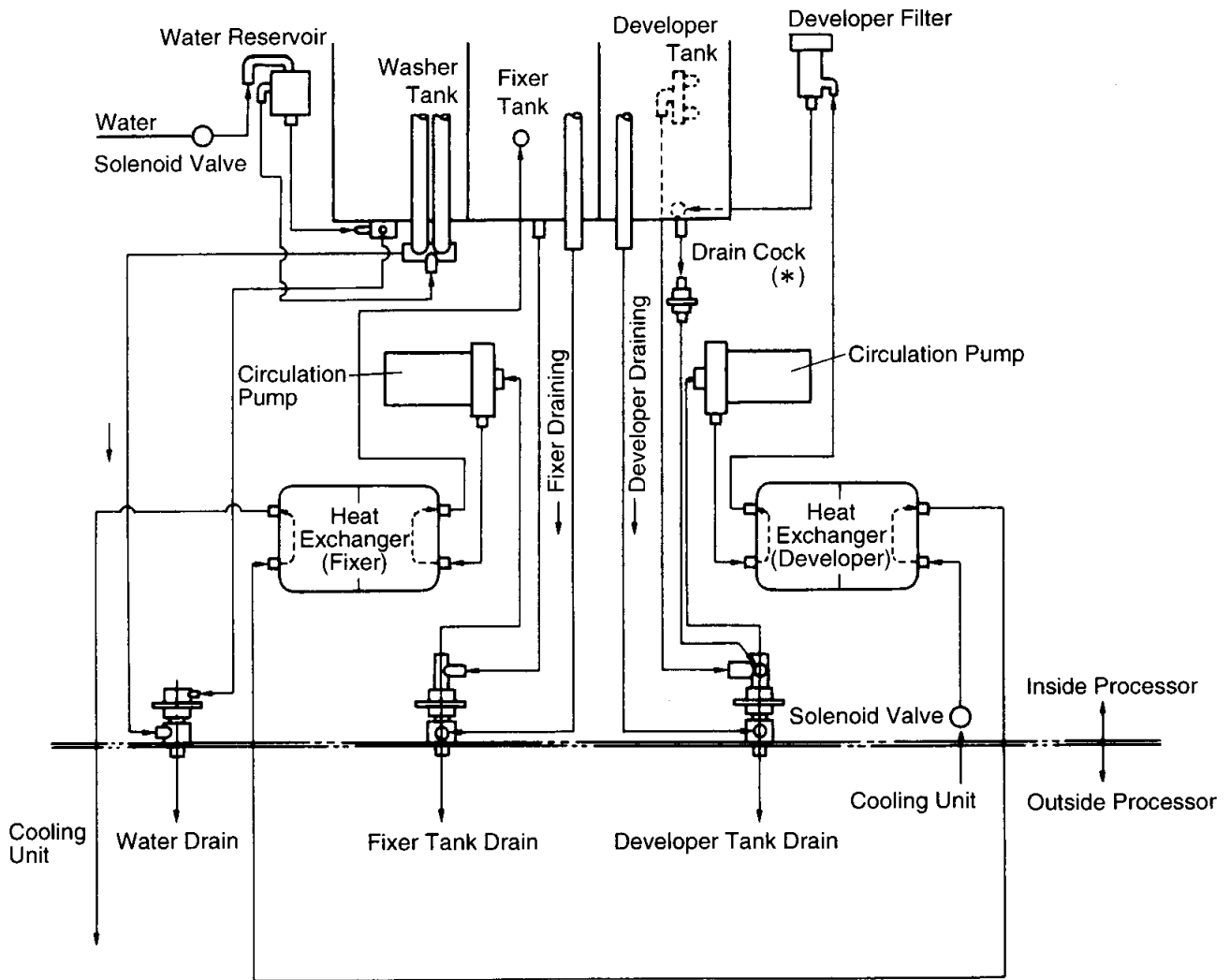

(*) Note Developer drain cock is opened only for draining chemical. During operation, this cock should be closed. After refilling developer, be sure to close the cock securely.

8. Mechanical Data

(1) Line Speed

5 Min Cycle	9.9mm/sec
11 Min Cycle	5.0mm/sec

9 Min Cycle	6mm/sec
13 Min Cycle	4mm/sec

(2) Processing Speed (Top to Top)

5 Min Cycle	5min 28sec
11 Min Cycle	10min 52sec

9 Min Cycle	9min 03sec
13 Min Cycle	13min 35sec

(3) Processing Steps

[Unit : sec]

	Insertion	Developer		Fixer		Washer In	Squeegee	Dryer
		In	Out	In	Out			
Mark	①	②	③	④	⑤	⑥	⑦	⑧
5 Min Cycle	15	60	30	65	30	60	35	50
9 Min Cycle	25	100	50	108	50	100	58	83
11 Min Cycle	30	120	60	130	60	120	70	100
13 Min Cycle	38	150	75	162	75	150	87	125

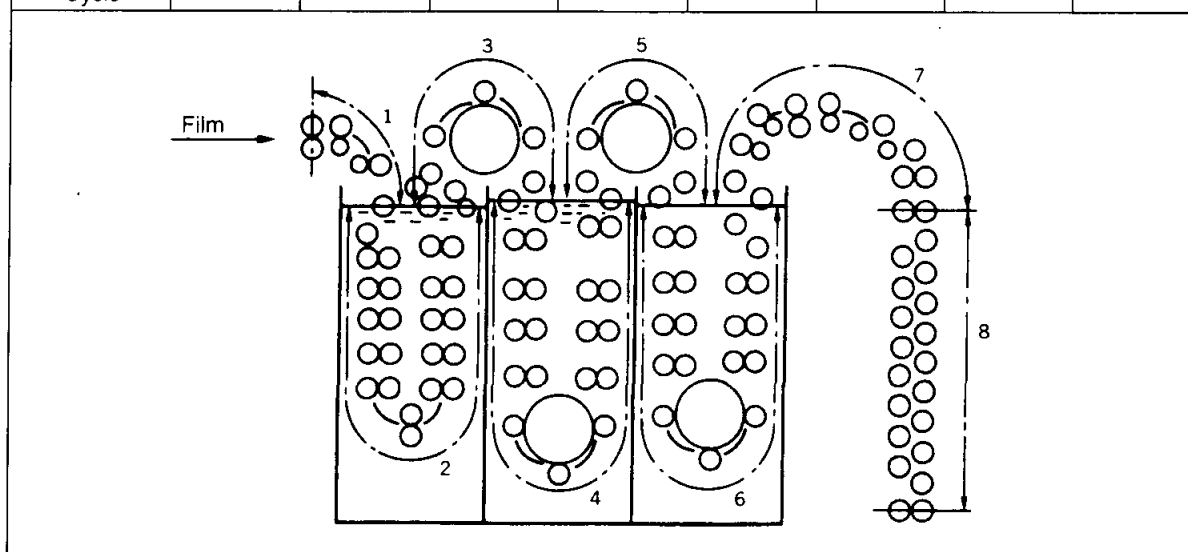

(4) Rack Weights

Developer Rack	19 kg	
Fixer Rack	17	
Washer Rack	16	
Entrance Rack	4	
D.Crossover Rack	5	
F.Crossover Rack	5	
Squeegee Rack	8	

(5) Drain Time

Developer	2Min30sec
Fixer	2Min
Wash	2Min

9. Adjustments

[1] Rack

(1) Rack Distortion

- Make sure that the rack sits flush on the flat platform surface.
- When checking the racks for distortion, place the developer, fixer and wash racks on the flat surface in the upright position and the entrance, developer crossover, fixer crossover and squeegee racks upside down.
- If any of the racks are found to be distorted, loosen the rack configuration retention bolts and straighten its geometry.

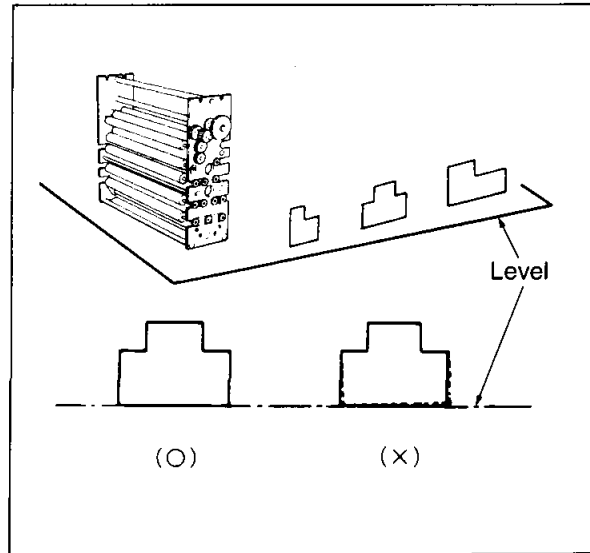

(2) Chain Alignment (Developer, fixer and wash racks)

- When any rollers are out of alignment, rollers do not rotate uniformly, causing uneven processing. Check and adjust roller rotation in the following manner.
- Turn the worm gears clockwise and make sure that they turn freely.

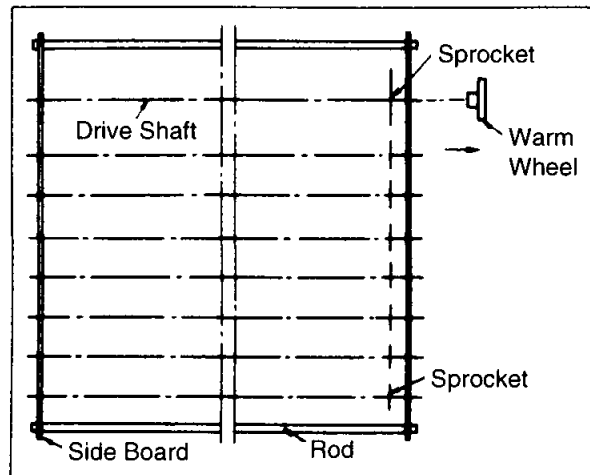

- If a worm gear cannot be turned freely and lightly, or if there is some excessive resistance, or if any of rollers do not rotate while the worm gear is turned, adjust chain according to the procedures indicated below.
 1. Loosen the hexagonal nut of the large chain sprocket.
 2. Firmly set the smaller chain sprockets to the smaller rollers (O. D. 25mm) at the correct position.
 3. Turn quickly the worm 7 to 8 times.
 4. Tighten the hexagonal nut of the large chain sprocket.
 5. Turn the worm clockwise and make sure that they turn freely.

(3) Ladder Chain Tension

Check the ladder chain for proper tension. If the chain is too slack the rollers will not rotate evenly. If the tension is not sufficient, reduce the slack using the following procedure.

Loosen the nut and adjust the play (A) in the ladder chain to the specified amount by moving the tension pulley.

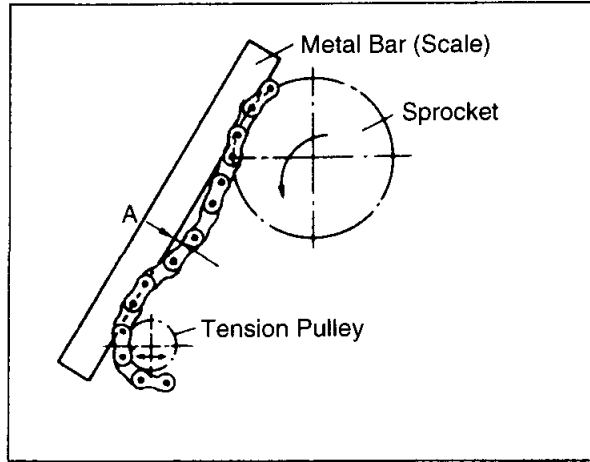

Developer Rack	$A=8\pm 1\text{mm}$
Fixer Rack	$A=6\pm 1$
Washer Rack	$A=6\pm 1$

(4) Turn Guide Plates (Developer, fixer, wash, developer crossover, and fixer crossover racks)

- Turn screws at both side plates and adjust \textcircled{A} to obtain the specified clearance between roller surface and guide plate edge.
- Use a thickness gauge, or sheets of film.
The thickness of one sheet of film is about 0.2mm.
- Adjust the amount so that the guide plate is aligned at both sides.

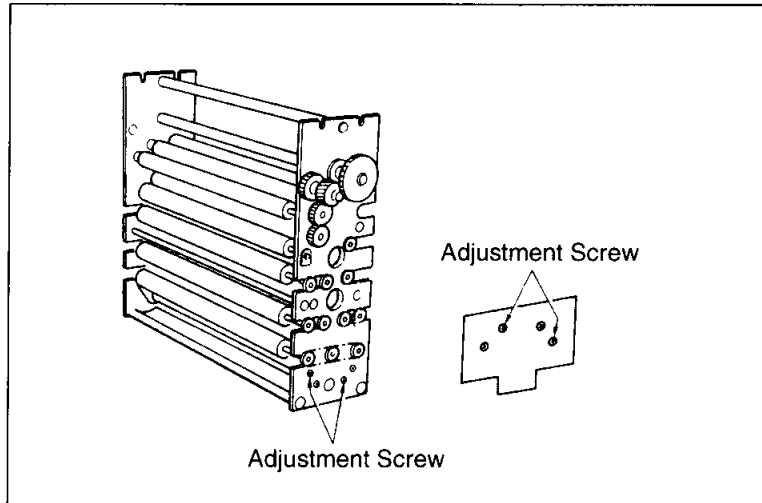

[: mm]

Developer Rack	$\textcircled{A}=1.5\sim 2.5$
Fixer Rack	
Washer Rack	
D-F Cross Rack	$\textcircled{A}=2.5\sim 3.5$
F-W Cross Rack	$\textcircled{A}=2.0\sim 3.0$

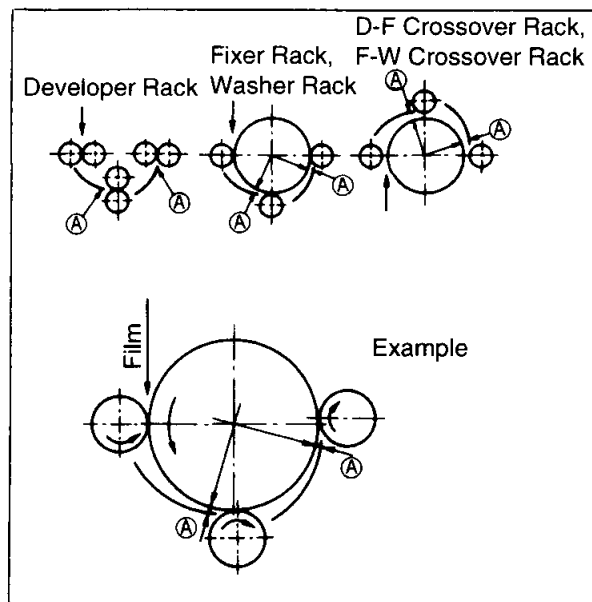

- After adjustment, make sure screws are tighten up firmly.
- Process several sheets of film to make sure guide plates are set at the right position.

- Whenever there is an indication that they are out of alignment, re-adjust guide plates.

NOTE :

- Guide plates of the entrance and squeegee racks need no adjustments.
- Make sure a guide plate is installed in the right direction in right and left sides to align with the length of roller.

(5) Gears and bearings

Check the gears and bearings for damage or excessive wear and replace any that are compromised beyond use.

Make sure that each bearing is set with an E-ring.

(6) Springs

Check to insure that none of the springs are out of place, fatigued or broken. If out of place, reinstall correctly and replace if found defective.

[2] Chemicals Circulation Line

(1) Chemical Level (Developer, Fixer, and Wash)

- Only the developer tank allows level adjustment.

Standard level

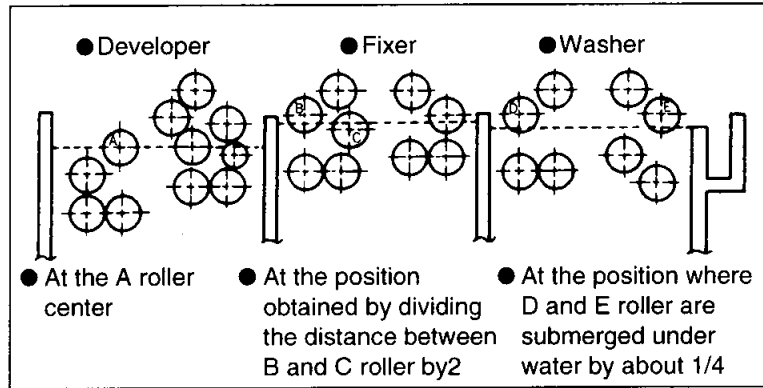

Chemical level adjustments

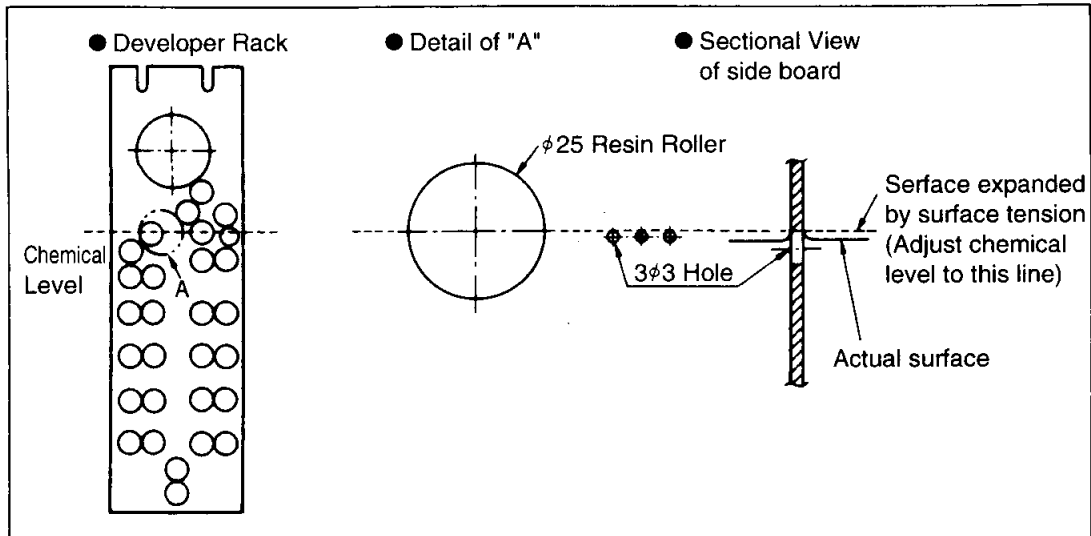

- Adjust the overflow nozzle so that surface tension level comes to the position.
- Tighten the nut to fix the overflow nozzle position.

(2) Chemical Tank

- Referring to the numbers shown in the diagram below, adjust chemical tank positioning by loosening 3 screws.

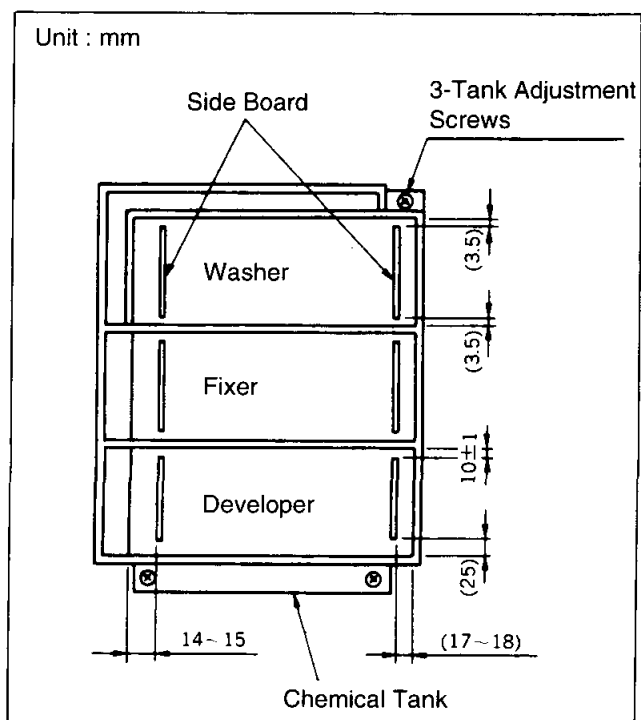

[3] Feed Tray

Incorrectly assembled feed tray may cause scratches on the film surface. Adjust the feed tray in the following manner.

- Remove roller (1), and insert a film. Make sure the film leading edge touches with roller (2). Set the feed tray so that the tray surface is placed 1 to 1.5mm lower from the contact point of two entrance rollers.

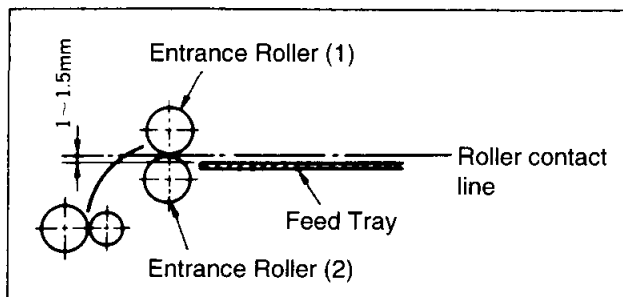

[4] Drive

When teeth of gears are not correctly engaged, rack rollers do not rotate in a uniform manner, causing processing troubles.

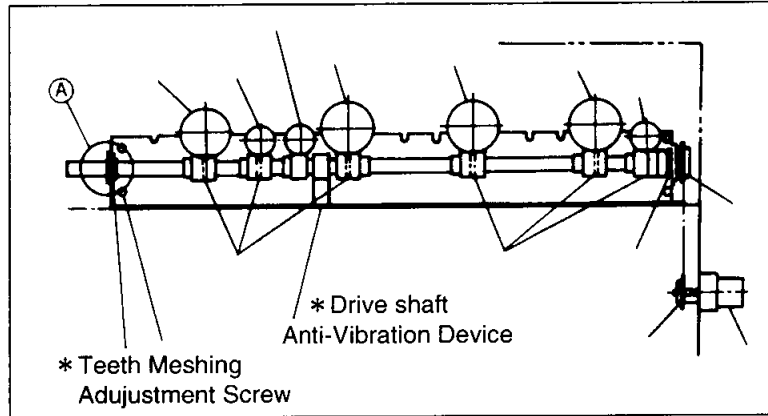

[5]-1 Worm Gears

- Loosen the vibration stop screw for the drive shaft, then adjust engagements by using screws with * mark in the diagram above.
- First using screws (1) adjust meshing amount. Second, pull up bracket (b) and secure position by tightening up screw (2).
- Tighten the vibration stop screw securely.

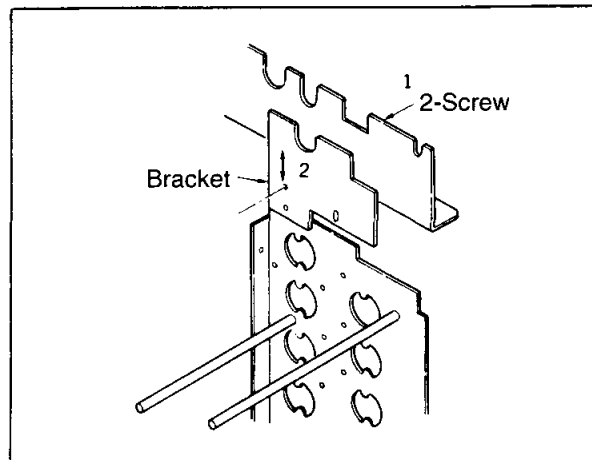

[5]-2 Drive Shaft Thrusting Direction Play

Referring to the diagram below, adjust the play from 0.5 to 1mm while the shaft is pushed all the way in arrow direction.

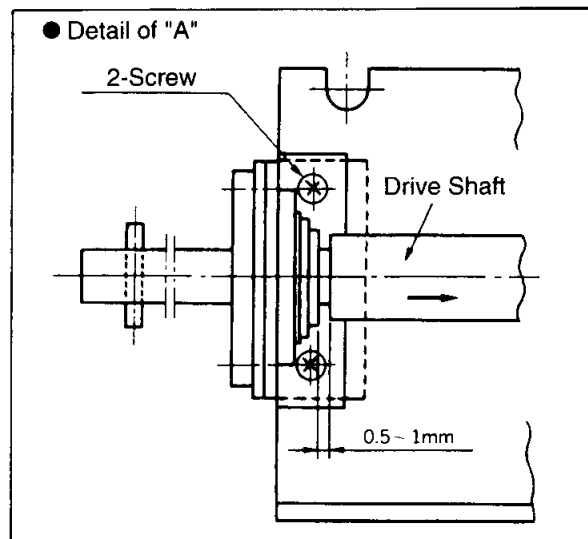

10. Removing The Side Panel

To dismount side panels ① and ②, remove the retaining screws in the shaded area. To dismount side panel ③, remove the shielding velour in the shaded area first and then the screws and bracket.

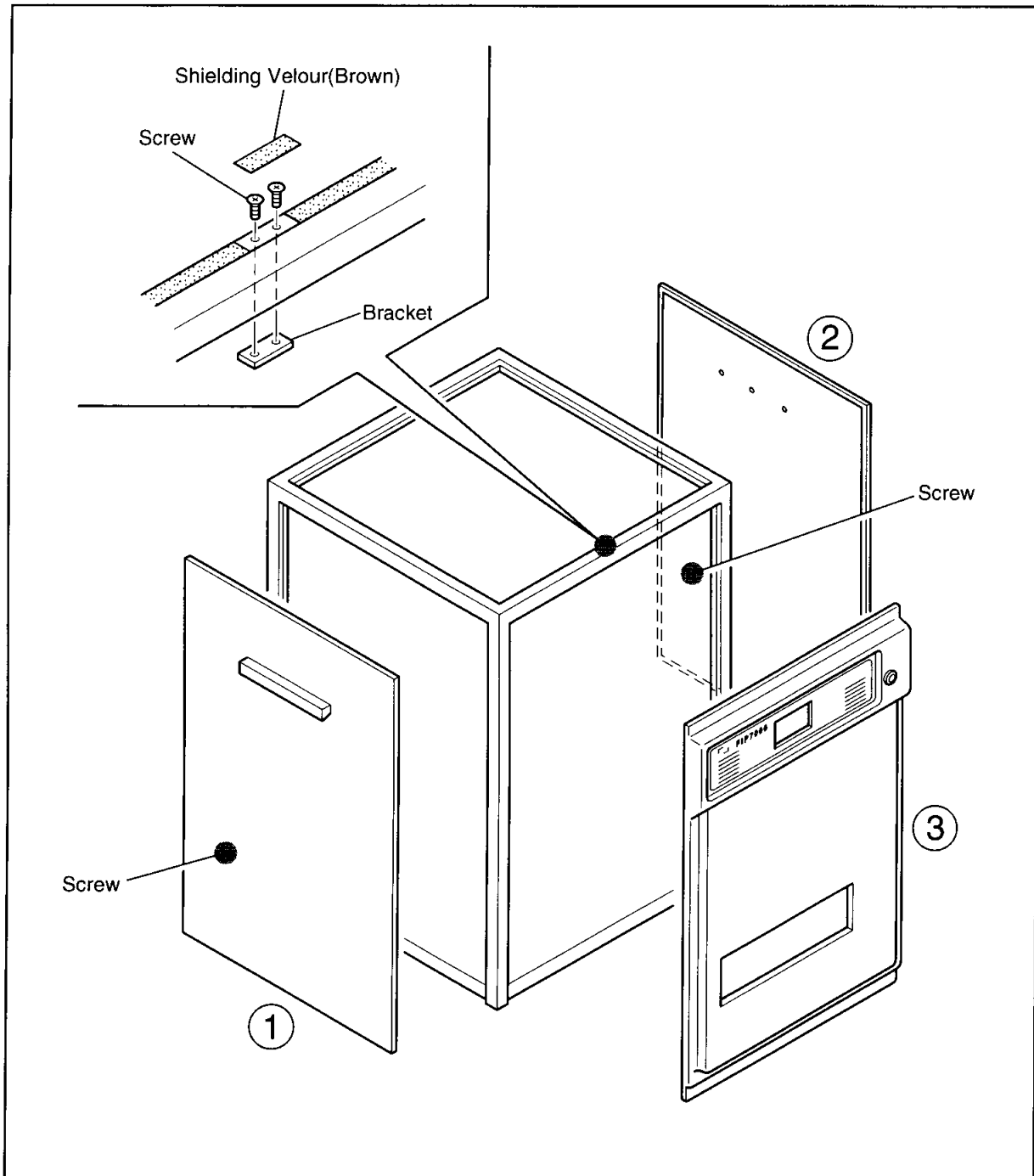

Contents FIP7000 Electrical Service Manual

1. Sequence Diagram	31
2. Developer Temperature Control	33
3. Fixer Temperature Control	34
4. Dryer Temperature Control	35
5. Circulation Pump	37
6. Replenishment	38
7. Drive Motor	40
8. Exhaust Fan	41
9. Alarm Buzzer	42
10. Ready	43
11. Dip Switch	44
12. Error	45
13. Operation Mode Descriptions	53
13.1 Operation Panel External View	53
13.2 Component Functions	53
13.3 Operation Mode Structure	55
13.4 Screen Hierarchy	57
13.5 Normal Mode	60
13.6 Setup Mode	63
13.7 Service Mode	76
13.8 Maintenance Mode	77
14. Troubleshooting Guide	92
15. Circuit Diagram-1	93
16. Circuit Diagram-2	95
17. Main Body Parts Arrangement Diagram	97





1. Sequence Diagram

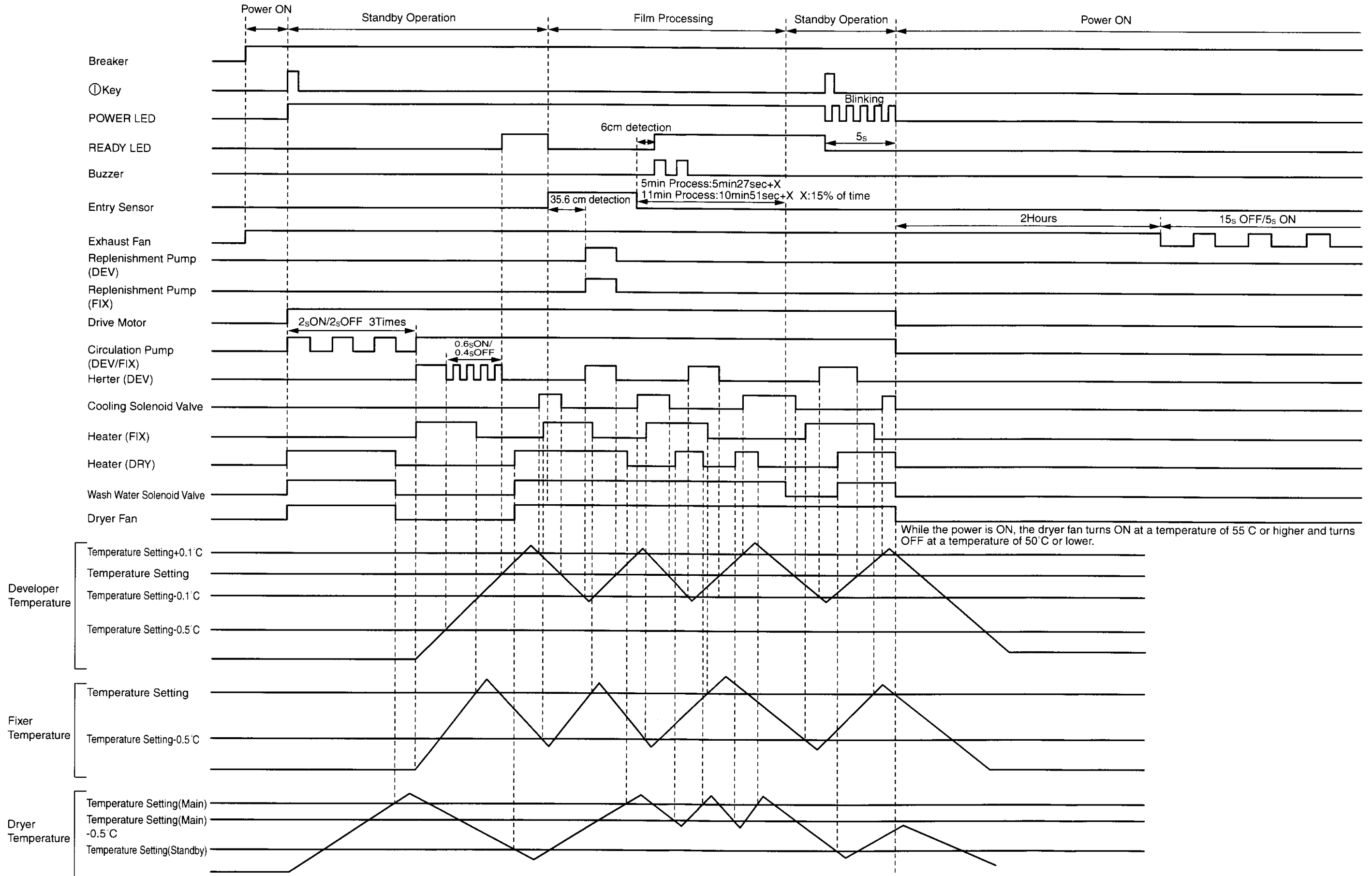

2. Developer Temperature Control

2.1 The diagram below shows how the developer temperature is controlled during standby operation, film processing, selftest bypass processing, maintenance mode, and service mode periods.

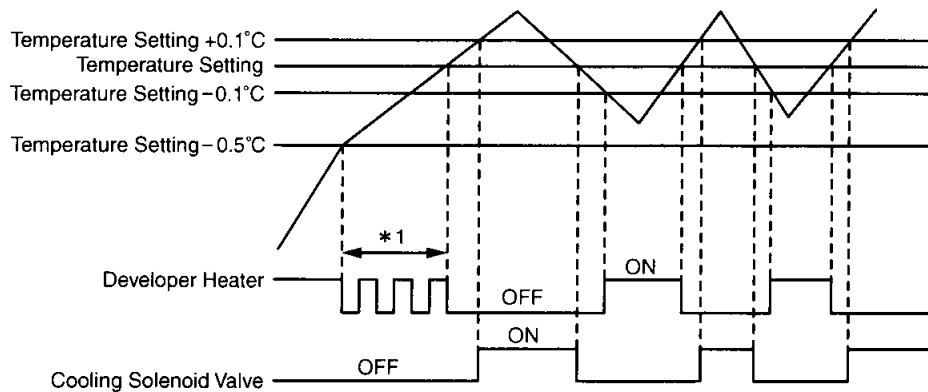

(a) During temperature increase

The developer heater (H1) turns OFF when the temperature setting \leq developer temperature. However, when the developer temperature control is not ready and (temperature setting $- 0.5^{\circ}\text{C}$) \leq developer temperature, the developer heater is controlled at an ON-OFF ratio of 6:4 (0.6-second-ON and 0.4-second-OFF) (* 1).

The cooling solenoid valve turns ON when the (temperature setting $+ 0.1^{\circ}\text{C}$) \leq developer temperature.

(b) During temperature decrease

The developer heater (H1) turns ON when the (temperature setting $- 0.1^{\circ}\text{C}$) \geq developer temperature.

The cooling solenoid valve turns OFF when the (temperature setting) \geq developer temperature.

2.2 Preheat operation descriptions are given below

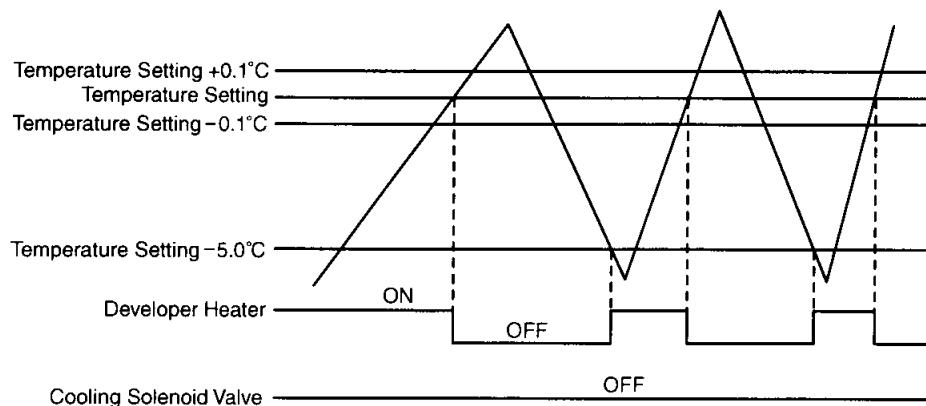

(a) During temperature increase

The developer heater (H1) turns OFF when the temperature setting \leq developer temperature.

(b) During temperature decrease

The developer heater (H1) turns ON when the (temperature setting $- 5^{\circ}\text{C}$) \leq developer temperature.

3. Fixer Temperature Control

3.1 The diagram below shows how temperature control is exercised during standby operation, film processing, selftest bypass processing, maintenance mode, and service mode periods.

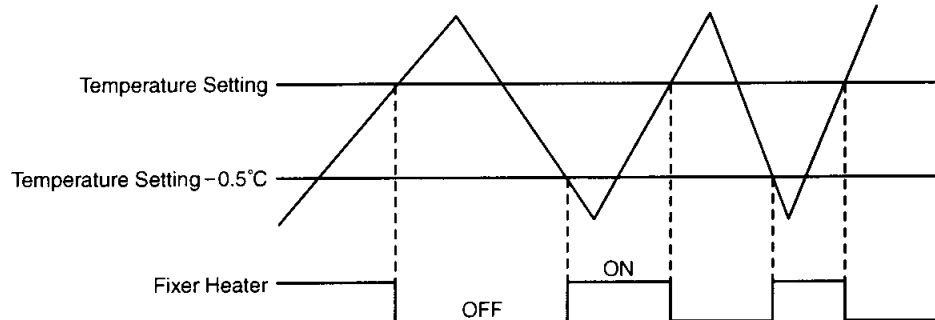

- (a) During temperature increase
The fixer heater (H2) turns OFF when the temperature setting \leq fixer temperature.
- (b) During temperature decrease
The fixer heater (H2) turns ON when the (temperature setting - 0.5°C) \geq fixer temperature.

3.2 Pleheat operation discriptions are given below

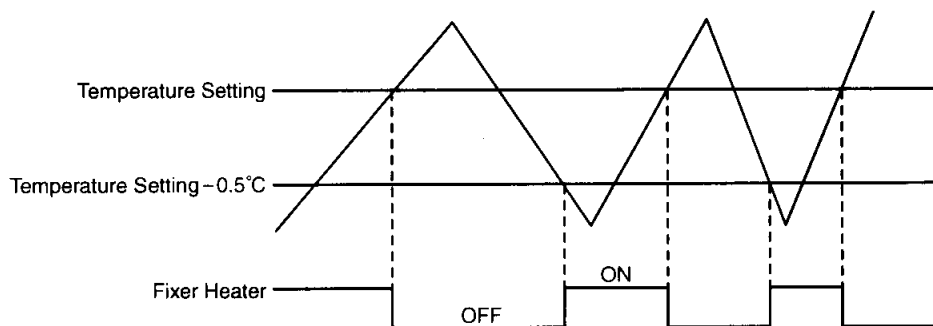

- (a) During temperature increase
The fixer heater (H2) turns OFF when the temperature setting \leq fixer temperature.
- (b) During temperature decrease
The fixer heater (H2) turns ON when the (temperature setting - 5.0°C) \geq fixer temperature.

4. Dryer Temperature Control

4.1 Standby temperature control

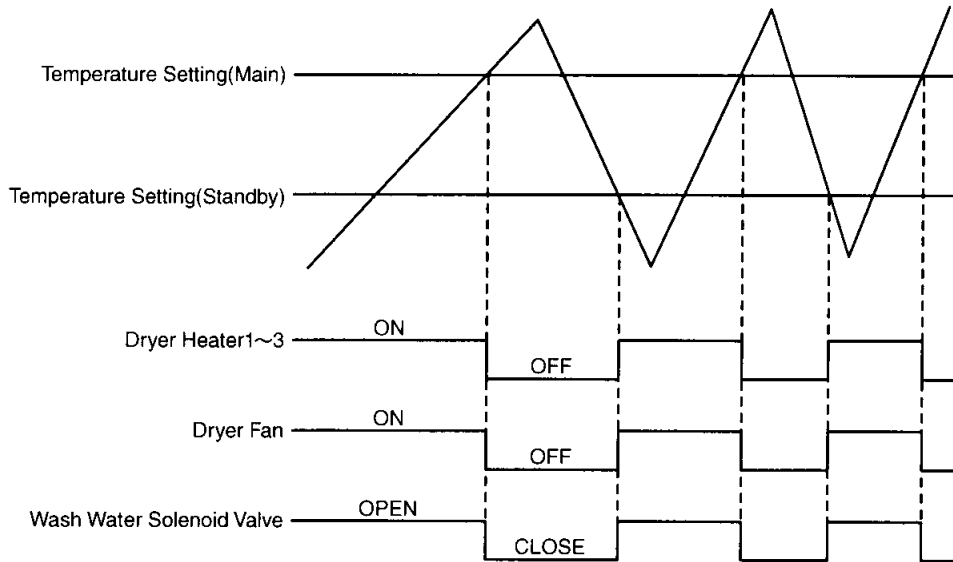

(a) During temperature increase

Temperature Setting(Main) \leq Dryer Temperature...Dryer Heater, Dryer Fan, Wash Water Solenoid Valve OFF

(b) During temperature decrease

Temperature Setting (standby) \geq Dryer Temperature...Dryer Heater, Dryer Fan, Wash Solenoid Valve ON

However, if the machine switches from the processing period temperature control mode to the standby temperature control mode, the dryer fan remains ON until the preselected dryer temperature (standby temperature) is reached.

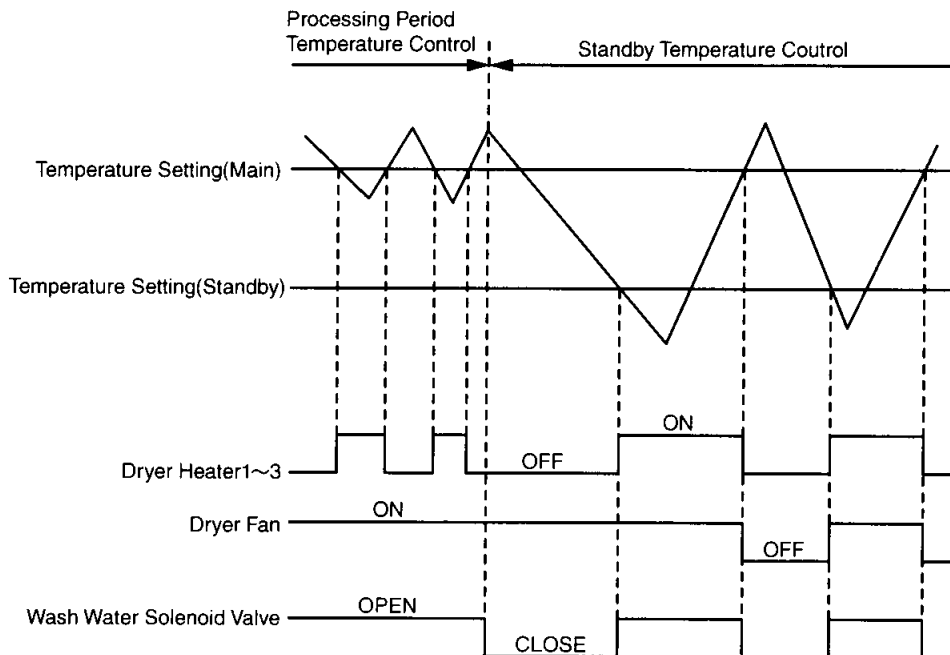

4.2 Processing Period Temperature Control

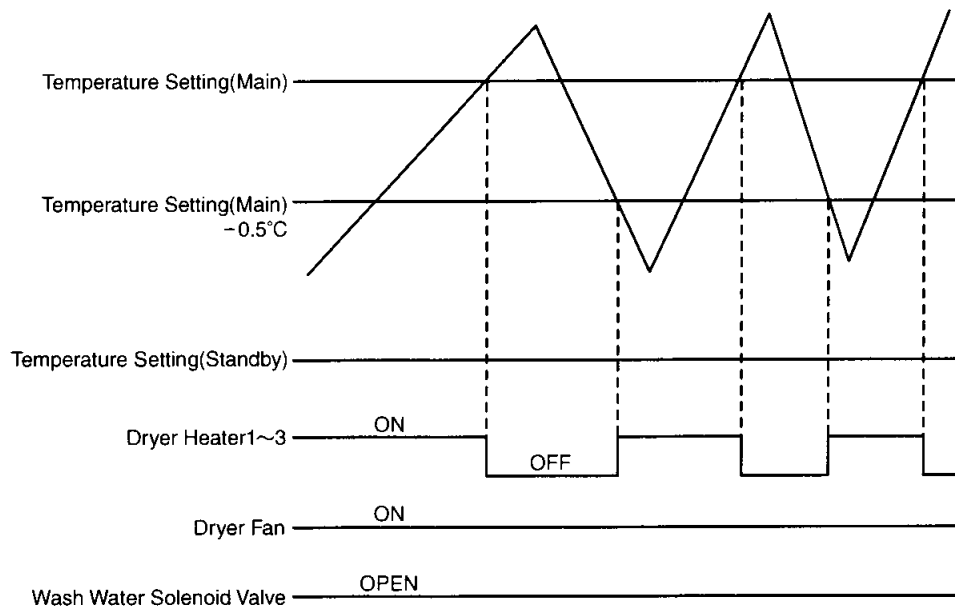

- (a) During temperature increase
 $\text{Temperature Setting(Main)} \leq \text{Dryer Temperature} \cdots \text{Dryer Heater OFF}$
- (b) During temperature decrease
 $\text{Temperature Setting(Main)} - 0.5^\circ\text{C} \geq \text{Dryer Temperature} \cdots \text{Dryer Heater ON}$

4.3 Dryer Fan Control

- (1) As regards the dryer temperature control period, see Sections 4.1 and 4.2.
- (2) If the machine is not in state (1):
 $\text{Dryer temperature} \geq 55^\circ\text{C} \cdots \text{The dryer fan turns ON.}$
 $\text{Dryer temperature} \leq 50^\circ\text{C} \cdots \text{The dryer fan turns OFF.}$

5. Circulation Pump

5.1 Film Processing, Selftest bypass Processing

Remains ON. Developer/fixer circulation pump

5.2 Standby operation, Pleheat operation

Performs an intermittent operation and then remains ON. Developer/Fixer Circulation Pump

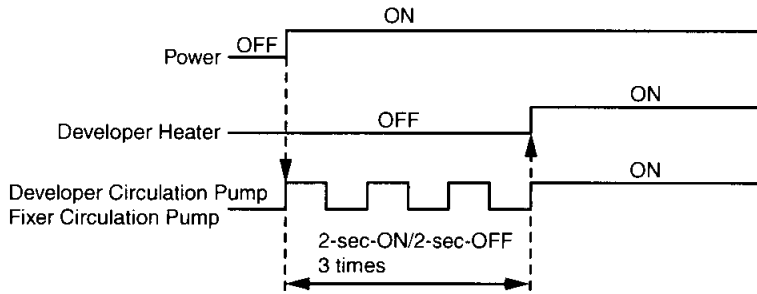

6. Replenishment

6.1 Replenishment Rate, Replenishment Time

Processing Speed	Replenishment Rate (ml/14x17inch) (Adjustment Range)	
	Dev	Fix
5Min27Sec	100 (30~150)	300 (70~300)
9Min3Sec	100 (30~150)	200 (60~240)
10Min51Sec	100 (30~150)	300 (70~300)
13Min35Sec	100 (30~150)	200 (60~240)

Replenishment Time Replenishment Rate (Initial Value)

	Replenishment Time	Replenishment Rate (Initial Value)
Replenishment Pump (Dev)	7.5sec	100ml
Replenishment Pump (Fix)	22.5sec	300ml

6.2 Length-based Replenishment

When the entry sensor detects a length of 35.6 cm (this machine supports widths of up to 43.2 cm although the 14 x 17 inch size is 35.6 cm x 43.2 cm), the machine performs one cycle each of developer replenishment and fixer replenishment.

If length-based replenishment is not effected at the end of a day's operation, the length data is backed up for the next day's replenishment and the backed-up data is added to the next day's length data to properly time the replenishment operation.

The length data clears in the following events:

- RAM clearing
- Clearing by mode selection

The machine performs replenishment during standby operation and film processing.

When selftest bypass processing, does not perform replenishment.

[Film counter]

When a film feed sensor turns ON in situations where all the film feed sensors have been OFF, the film counter is incremented by one.

The film counter clears in the following events:

- RAM clearing
- Clearing by mode selection

6.3 Manual Replenishment

When REPL key is turned on for 1 second during, one cycle of replenishment is performed.

6.4 Fixed-time Replenishment

- When the fixed-time replenishment timer is turned ON, the replenishment pump operates for one cycle of replenishment. (The replenishment pump is corrected according to the amount of replenishment.)
- When the fixed-time replenishment timer is turned OFF during replenishment, it is stopped upon completion of one cycle of replenishment following the turn-off of the fixed-time replenishment timer.

6.5 Checking Replenishment

- When the checking replenishment timer is turned ON, the replenishment pump operates for one cycle of replenishment. (The correction value is checked for correctness based on the amount of replenishment.)
- When the checking replenishment timer is turned OFF during replenishment, it is stopped upon completion of one cycle of replenishment following the turn-off of the checking replenishment timer.

6.6 Replenishment Rate Calculation

The amounts of length-based replenishment and manual replenishment are added up (the amounts of fixed-time replenishment and checking replenishment are not added up).

The resulting cumulative replenishment amount clears in the following events:

- RAM clearing
- Clearing by mode selection

7. Drive Motor

7.1 Drive Motor Rotating Speed

- (1) Four different drive motor rotating speeds are available. These rotating speeds are combined to offer three different patterns. A DIP switch is used for pattern selection. Each pattern offers two speed options. One of the two speed options can be selected by performing a keying procedure in the associated mode.

Abbreviation	Processing Speed [Sec] (Top To Top)	Dev Immersion Time [sec]	Line Speed [mm/sec]	Three patterns 5min27sec/10min51sec 5min27sec/ 9min03sec 9min03sec/13min35sec
5min	327(5min27sec)	60	9.9	
9min	543(9min03sec)	100	6.0	
11min	651(10min51sec)	120	5.0	
13min	815(13min35sec)	150	4.0	

NOTE: The standard pattern is 5 min 27 sec/10 min 51 sec. The other patterns are available on indent.

* The film processing time is measured as the time elapse after film trailing end detection by a film feed sensor. It is determined by adding a 15% margin to the time indicated in the above table (in the same manner as for the FPM6000NDT).

- (2) When the top cover opens, the drive motor stops (interlock).
- (3) If a keying procedure is performed to change the speed in the film processing mode or selftest bypass processing mode, the keyed-in speed change takes effect when the mode terminates. If the speed change keying procedure is performed during a standby operation, the keyed-in speed change takes effect immediately. However, it takes several seconds for the speed to stabilize.

7.2 Standby operation, Film processing, Selftest bypass processing, Stop process

Remains ON.

8. Exhaust Fan

8.1 During Power-failure sequence, standby operation, film processing, stop process, or selftest bypass processing the exhaust fan is ON

8.2 When the film processor is energized and the preheat operation started, the exhaust fan is ON for the first 2 hours. Subsequently, however, the exhaust fan repeats 15-seconds-OFF and 5-seconds-ON intermittent operations.

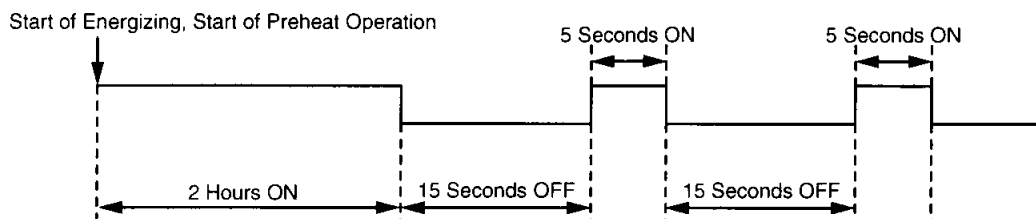

8.3 When the film processor is maintenance mode and service mode operation the exhaust fan is OFF

9. Alarm Buzzer

9.1 How the Alarm Buzzer Sounds

9.1.1 Alarm buzzer operation performed upon error occurrence.

When an error occurs, an alarm buzzer continuously sounds. It stops sounding at the press of the alarm OFF key.

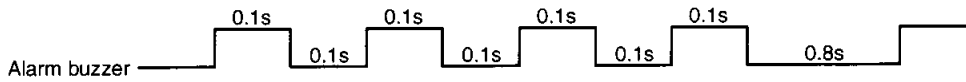

9.1.2 Alarm buzzer operation performed when the ① key is pressed during film processing.

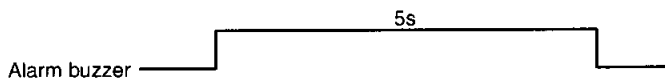

9.1.3 Alarm buzzer sounding to indicate the readiness to accept film input during film processing.

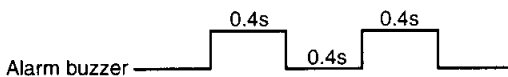

9.1.4 Alarm buzzer operation performed key activation

The alarm buzzer sounds for 0.1 second.



9.1.5 Alarm buzzer operation performed When the cumulative replenishment amount and error log clear signal input is accepted.

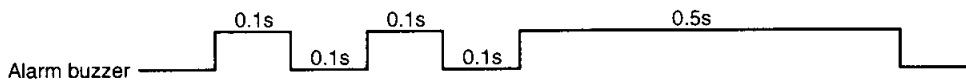

9.2 Alarm Buzzer Priority

The alarm buzzers sound in the following priority order. If a buzzer is requested while a buzzer having a lower priority is sounding, the former sounds and the latter becomes silent.

<Priority order>

- ① Error alarm buzzer
- ② Alarm buzzer that sounds when the ① key is pressed during film processing
- ③ Alarm buzzer that sounds when the machine is ready for film feed
- ④ Alarm buzzer that sounds to indicate the acceptance of a data clear procedure performed in the associated mode
- ⑤ Alarm buzzer that sounds when a key is pressed

10. Ready

The machine checks whether the Ready conditions are met. When all the Ready conditions are met, the READY LED on the operation panel comes on. If any Ready condition is unmet, the READY LED goes off.

	Ready conditions	Standby operation Film processing	Selftest bypass processing	Other
①	No film is detected by the film feed sensor. Also, the specified delay time has passed after film trailing end detection.			
②	The POWER LED is lit			
③	<p>The Ready condition is indicated by developer temperature control system</p> <p><1> When an operation is started, the setting is changed, or the status changes from "Ready" to "Not Ready":</p> <p>1) While the temperature is increasing The machine is Ready when the following is satisfied: Developer temperature \geq temperature setting</p> <p>2) While the temperature is decreasing The machine is Ready when the following is satisfied: Developer temperature \leq (temperature setting + 0.3)$^{\circ}$C</p> <p><2> In a situation other than <1>: The machine is Ready when the following is satisfied: (Temperature setting - 1.0)$^{\circ}$C \leq developer temperature \leq (temperature setting + 1.0)$^{\circ}$C</p> <p><3> If condition <2> is not satisfied or the temperature setting is changed, the machine is Not Ready.</p>	Considered as Ready state judgment conditions	Ready unconditionally.	Not Ready
④	<p>The Ready condition is indicated by fixer temperature control system.</p> <p><1> When an operation is started, the setting is changed, or the status changes from "Ready" to "Not Ready": The machine is Ready when the following is satisfied: Temperature setting \leq fixer temperature \leq 35$^{\circ}$C</p> <p><2> In a situation other than <1>: The machine is Ready when the following is satisfied: 28$^{\circ}$C \leq fixer temperature \leq 35$^{\circ}$C</p> <p><3> If condition <2> is not satisfied or the temperature setting is changed, the machine is Not Ready.</p>			
⑤	<p>The Ready condition is indicated by dryer temperature control system.</p> <p><1> When an operation is started, the setting is raised, or a dryer temperature control error occurs: The machine is Ready when the following is satisfied: Dryer temperature nnn temperature setting (main)</p> <p><2> If the setting is raised or a dryer temperature control error occurs, the machine is Not Ready.</p>			

When the top cover is found to be open, the READY LED goes off because the drive motor stops (interlock), making it impossible to perform a film processing operation.

11. DIP Switch

- (1) An 8-bit DIP switch is mounted on the NMC circuit board.
- (2) The DIP switch retains the state that prevails upon power ON. (Even if you change the DIP switch setting after power ON, the change does not take effect until you turn the power OFF and then back ON.)

11.1 DIP Switch Initial Setup

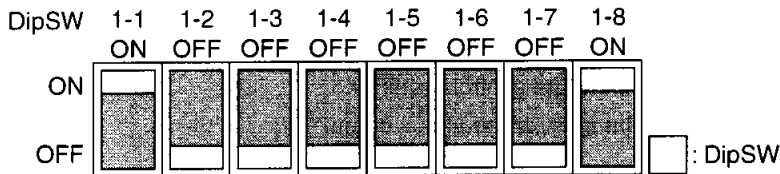

11.2 DIP Switch Functions

DipSW	Description	DipSW																	
		OFF	ON																
1-1		Fixed to ON																	
1-2		Fixed to OFF																	
1-3		—	—																
1-4		—	—																
1-5 1-6	Mode Change (drive speed)	<table border="1" style="width: 100%;"> <thead> <tr> <th colspan="2">DipSW</th> <th rowspan="2">Drive speed</th> </tr> <tr> <th>1-5</th> <th>1-6</th> </tr> </thead> <tbody> <tr> <td>OFF</td> <td>OFF</td> <td rowspan="2">5min27sec/10min51sec</td> </tr> <tr> <td>ON</td> <td>ON</td> </tr> <tr> <td>ON</td> <td>OFF</td> <td>9min3sec/13min35sec</td> </tr> <tr> <td>OFF</td> <td>ON</td> <td>5min27sec/9min3sec</td> </tr> </tbody> </table> <p style="text-align: right;">} *</p>		DipSW		Drive speed	1-5	1-6	OFF	OFF	5min27sec/10min51sec	ON	ON	ON	OFF	9min3sec/13min35sec	OFF	ON	5min27sec/9min3sec
DipSW		Drive speed																	
1-5	1-6																		
OFF	OFF	5min27sec/10min51sec																	
ON	ON																		
ON	OFF	9min3sec/13min35sec																	
OFF	ON	5min27sec/9min3sec																	
1-7	Circuit Board Inspection	Normal Control	Circuit Board Inspection																
1-8	Saved data handling on power ON	The saved data is cleared	The saved data is used																

* Available on indent.

12. Error

12.1 Error Levels and Processing Descriptions

For the FIP7000, errors may occur in the following situations.

- (1) A certain function is exercised in the maintenance or service mode.
- (2) An operation is invoked during standby or film processing.

Errors occurring in case 2) above are classified into the following three categories depending on the severity of error. Errors occurring in case 1) above simply stop the ongoing process and are not classified into categories at all.

- (1) Serious-level errors
Stop the ongoing operation.
- (2) Minor-level errors
Allows the system to continue with its operation.

12.1.1 Serious-level Errors

If this type of error occurs, the system executes the following process.

- (1) Gives an error indication.
- (2) Immediately stops the error occurrence section.
- (3) Turns OFF the READY signal output to the hookup equipment.
- (4) Performs the stop process 25 seconds after completion of step 3) (because no more film will possibly be fed into the film processor).
- (5) When the stop process is completed, the film processor automatically goes into the "Power ON" state to return to the state prevailing before startup.

In this instance, the film processor can be started up again, but the same error occurs again because the error cause does not automatically clear.

As far as the error cause is not eliminated, such an error recurrence pattern is repeated and the film processor is not able to perform normal operations.

In some cases, however, the selftest bypass processing function can be executed upon error occurrence to carry out an alternative emergency process.

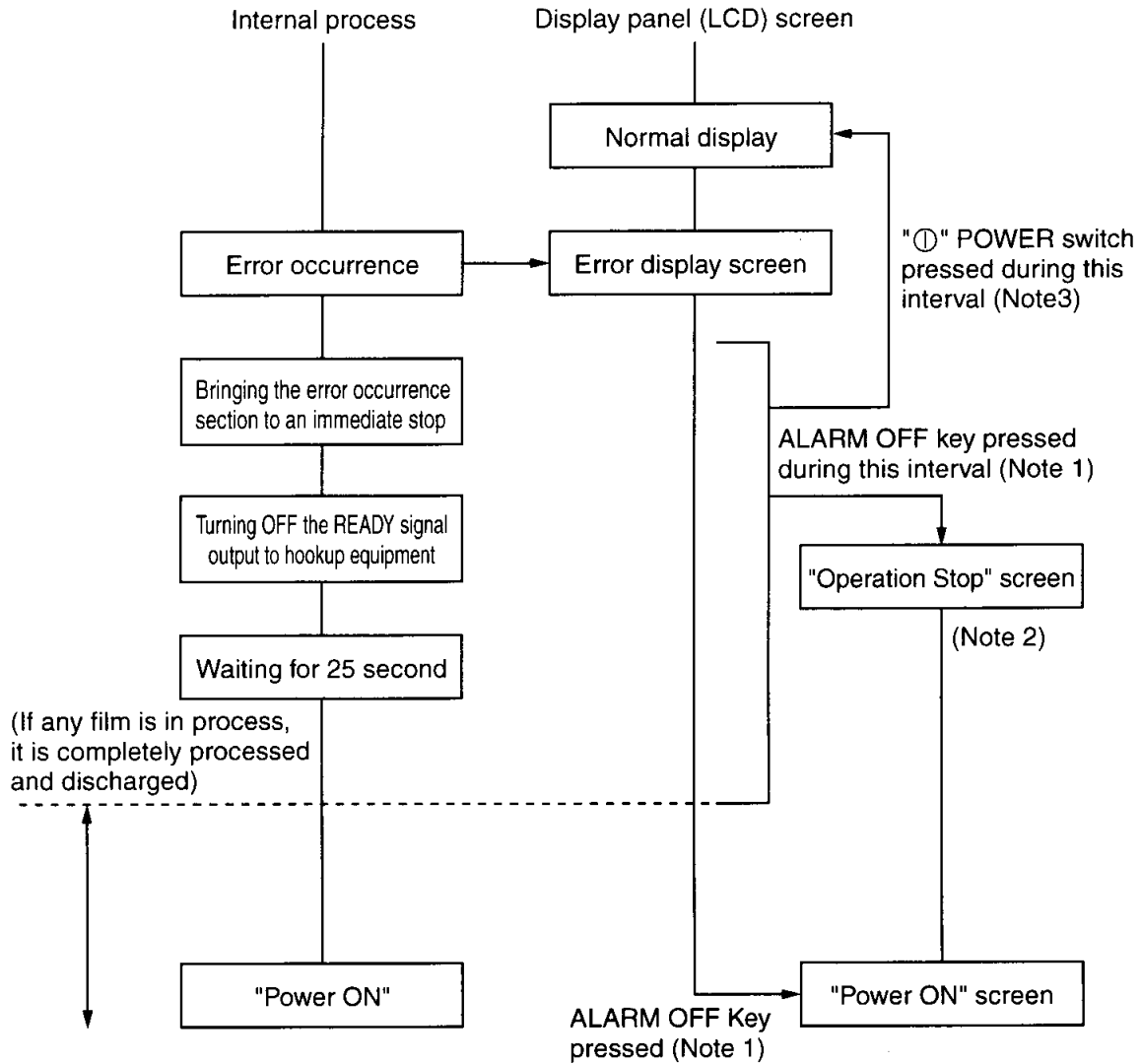

NOTE 1: If two or more errors have occurred, the error screens go off one by one at each press of the ALARM OFF key. When all error screens have disappeared, the "Operation Stop" or "Power ON" screen appears.

NOTE 2: When a serious-level error occurs, it may be detected again from the "Operation Stop" screen, causing the system to display the error screen again.

NOTE 3: Even if two or more errors have occurred, a single press of the POWER switch key causes the system to clear all errors and return to a normal screen. However, if a serious-level error has occurred, the system may detect the same error again after above POWER switch activation, displaying the same error screen. If the POWER switch is pressed once while an error screen is displayed in the "Power ON" state, the system performs the same process.

12.1.2 Minor-level Errors

Minor-level errors do not seriously affect film processing. They notify the user of an ancillary function error or alert the user to conditions which require attention. When this type of error occurs, the film processor internally disables the associated function and continues with the ongoing operation.

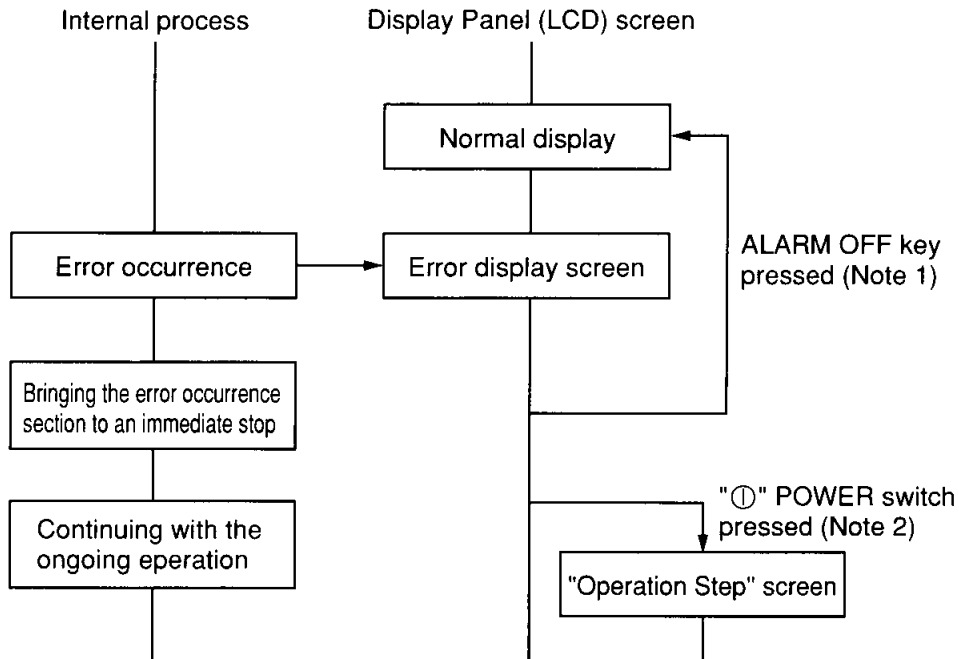

NOTE 1: If two or more errors have occurred, the error screens go off one by one at each press of the ALARM OFF key. When all error screens have disappeared, the system returns to a normal screen.

NOTE 2: If the POWER switch is pressed once, the system clears all the existing errors and returns to the "Operation Stop" screen.

12.2 Selftest Bypass Operation

The selftest bypass operation function is exercised, if normal processing function execution is interrupted by an error occurrence, to carry out an urgent operation or continue with operations until the service personnel arrives. The selftest bypass operation function permits the continuation of operations after the occurrence of an error as far as the error does not expose operating personnel to hazardous conditions. The features of the selftest bypass operation function are summarized below.

- High-temperature abnormality, thermistor abnormality (open circuit or short circuit), or other error that endangers the operating personnel engaged in a selftest bypass operation will be detected even during selftest bypass operation function execution to stop the ongoing operation.
- If any hazardous error occurs during a selftest bypass operation, the system performs the same process as for a serious-level error occurrence during a normal operation.
- If a nonhazardous error occurs during a selftest bypass operation, the system performs the same process as for a minor-level error occurrence during a normal operation and does not

detect such a nonhazardous error. However, the system simply disables the function related to the error encountered.

- Some errors do not occur during selftest bypass processing (these errors are marked “ – ” in Table 1/12.5 Error Codes).

12.3 Display Panel (LCD) Indications

Error indications appearing on the display panel (LCD) consist of 2 lines of 16 one-byte (alphanumeric characters) characters.

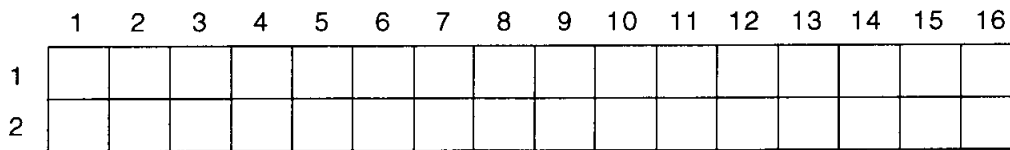

Fig. 3 Display Panel (LCD) Error Indication Character String Limitation

12.4 Error Logging

Errors whose codes begin with the letter E are all logged.

12.5 Error Codes

Error codes and error processing operations to be performed are summarized in Table 1.

Table 1 Error Indications and Processing Operations

Error code	Error level	On-screen message	Selftest Bypass processing period	Error cause	Processing performed after error occurrence
E000	Undefined	SETUP DATA ERROR	–	This error occurs if the NG result is obtained from the save data area check conducted upon power ON.	The save data area is initialized to continue with the ongoing process. (After the occurrence of this error, it is necessary to enter temperature and replenishment calibration data.)
E001	Undefined	PROCESSING AFTER POWER FAILURE	–	The power turned OFF while the previously fed film was in process.	No particular process is performed.

Error code	Error level	On-screen message	Selftest Bypass processing period	Error cause	Processing performed after error occurrence
E010	Serious	DEV. TEMPERATURE TOO HIGH	Detected	A developer solution temperature of 42°C was exceeded.	<ul style="list-style-type: none"> ● The developer temperature control system is brought to an immediate stop. ● The stop process is performed.
			Not detected	The preselected temperature was exceeded by more than 4°C after the developer temperature control READY condition was established.	
E020	Serious	DEV. TEMPERATURE TOO LOW	Not detected	The temperature was more than 4°C below the setting continuously for a period of 10 minutes or longer after the developer temperature control READY condition was established.	<ul style="list-style-type: none"> ● The developer temperature control system is brought to an immediate stop. ● The stop process is performed.
E030	Serious	DEV. HEATER MALFUNCTION	Not detected	Before developer temperature control READY condition establishment, the solution temperature did not rise by 1°C or more within 10 minutes after the start of developer temperature control	<ul style="list-style-type: none"> ● The developer temperature control system is brought to an immediate stop. ● The stop process is performed.
E040	Serious	DEV. THERMISTOR MALFUNCTION	Detected	The indicated thermistor temperature coincides with the open thermistor value (AD value: 30 or smaller).	<ul style="list-style-type: none"> ● The developer temperature control system is brought to an immediate stop. ● The stop process is performed.
E050	Serious	DEV. THERMISTOR SHORT CIRCUITED	Detected	The indicated thermistor temperature coincides with the shorted thermistor value (AD value: 219 or greater).	<ul style="list-style-type: none"> ● The developer temperature control system is brought to an immediate stop. ● The stop process is performed.

Error code	Error level	On-screen message	Selftest Bypass processing period	Error cause	Processing performed after error occurrence
E110	Serious	FIX. TEMPERATURE TOO HIGH	Detected	A fixer solution temperature of 40°C was exceeded.	<ul style="list-style-type: none"> ● The fixer temperature control system is brought to an immediate stop. ● The stop process is performed.
E120	Serious	FIX. TEMPERATURE TOO LOW	Not detected	The fixer solution temperature fell below 20°C after fixer temperature control READY condition establishment.	<ul style="list-style-type: none"> ● The fixer temperature control system is brought to an immediate stop. ● The stop process is performed.
E130	Serious	FIX. HEATER MALFUNCTION	Not detected	The fixer solution temperature did not rise by 1°C or more within 10 minutes after the start of fixer temperature control. However, this check is to be discontinued if the solution temperature reaches 28°C or higher during this period	<ul style="list-style-type: none"> ● The fixer temperature control system is brought to an immediate stop. ● The stop process is performed.
E140	Serious	FIX THERMISTOR MALFUNCTION	Detected	The indicated thermistor temperature coincides with the open thermistor value (AD value: 30 or smaller).	<ul style="list-style-type: none"> ● The fixer temperature control system is brought to an immediate stop. ● The stop process is performed.
E150	Serious	FIX. THERMISTOR SHORT CIRCUITED	Detected	The indicated thermistor temperature coincides with the shorted thermistor value (AD value: 219 or greater).	<ul style="list-style-type: none"> ● The fixer temperature control system is brought to an immediate stop. ● The stop process is performed.

Error code	Error level	On-screen message	Selftest Bypass processing period	Error cause	Processing performed after error occurrence
E210	Serious	DRY. TEMPERATURE TOO HIGH	Detected	The hot-air dryer temperature was above 73°C	<ul style="list-style-type: none"> • The hot-air dryer temperature control system is brought to an immediate stop. • The stop process is performed.
E220	Serious	DRY. TEMPERATURE TOO LOW	Not detected	<p>After hot-air dryer temperature control READY condition establishment, the temperature decreased as follows.</p> <ul style="list-style-type: none"> • The temperature decreased to 10°C lower than the standby lower limit during standby temperature control. 	<ul style="list-style-type: none"> • The hot-air dryer temperature control system is brought to an immediate stop. • The stop process is performed.
E230	Serious	DRY. HEATER MALFUNCTION	Not detected	The temperature did not rise by 3°C or more within 10 minutes after startup.	<ul style="list-style-type: none"> • The hot-air dryer temperature control system is brought to an immediate stop. • The stop process is performed.
E240	Serious	DRY THERMISTOR MALFUNCTION	Detected	The indicated thermistor temperature coincides with the open thermistor value (AD value: 20 or smaller).	<ul style="list-style-type: none"> • The hot-air dryer temperature control system is brought to an immediate stop. • The stop process is performed.
E250	Serious	DRY. THERMISTOR SHORT CIRCUITED	Detected	The indicated thermistor temperature coincides with the shorted thermistor value (AD value: 208 or greater).	<ul style="list-style-type: none"> • The hot-air dryer temperature control system is brought to an immediate stop. • The stop process is performed.

Error code	Error level	On-screen message	Selftest Bypass processing period	Error cause	Processing performed after error occurrence
E310	Serious	ENTRANCE SENSORS MALFUNCTION	–	Film was detected by the film feed sensor at the beginning of operation.	The startup process is stopped.
E340	Serious	DRIVE MOTOR MALFUNCTION	Detected	The drive motor rotating speed dropped to 30% or less of the specified level.	<ul style="list-style-type: none"> ● The motor is stopped. ● The stop process is performed.
E350	Minor	TOP COVER OPEN	Detected	In condition of power outage processing, standby, film processing, stop processing, selftest bypass processing, preheat operation, startup processing, an open top cover is detected.	<ul style="list-style-type: none"> ● The motor is stopped (interlock). ● Motor stop (interlock) ● When a closed top cover sensor is detected top cover, error message is cleared.

13. Operation Mode Descriptions

13.1 Operational Panel External View

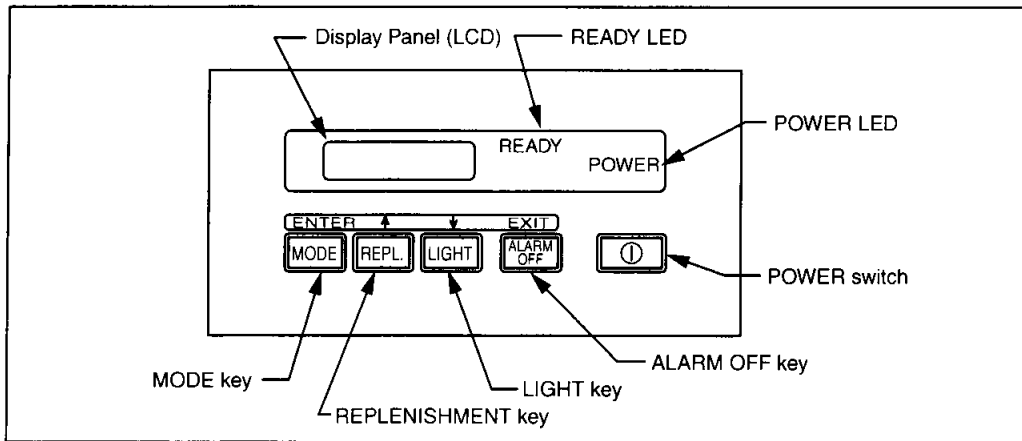

13.2 Component Functions

① Display panel (backlight [yellowish-green]) [16 characters x 2 lines]

Displays the film processor status, error information, individual mode operating steps, and other relevant instructions.

* Backlight operations

- Extinguished : The film processor is in the "Power ON" period.
- Illuminated : The film processor is engaged in operation, error handling, or particular mode function execution.

② POWER (green LED)

Indicates the film processor status.

- Steady glowing : The film processor is operating.
- Blinking : The system is trying to stop the film processor.
- Extinguished : The film processor is in the "Power ON" period, service mode, or maintenance mode.

③ READY (green LED)

Indicates whether the film processor is ready.

- Steady glowing : The film processor is ready for film processing.
- Extinguished : The film processor not ready for film processing.

④ POWER switch

Effects operation ON/OFF changeover.

⑤ **ALARM OFF** key (refer to the **EXIT** key)

1. Silences the Alarm buzzer when it sounds.
2. Clears existing errors (beginning with the latest error).
3. While the setup mode operation is being conducted, this key functions as the EXIT key.

- ⑥ **LIGHT** key (refer to the **↓** key)
1. Turns OFF the LCD backlight.
 2. While the setup mode operation is being conducted, this key functions as the **↓** key.
(When held down in an input value editing sequence, this key continuously varies the value.)
- ⑦ **REPL** key (refer to the **↑** key)
1. When held down for a period of longer than 1 second in the "Power ON" period, the replenishment solution supply sequence starts. (When the key is held down again for a period of longer than 1 second, the replenishment solution supply sequence is aborted.)
 2. When held down for a period of longer than 1 second during operation, the replenishment solution supply sequence starts. The preselected amounts of replenishment solutions (developer and fixer) are replenished in this sequence.
 3. While the setup mode operation is being conducted, this key functions as the **↑** key. (When held down in an input value editing sequence, this key continuously varies the value.)
- ⑧ **MODE** key (refer to the **ENTER** key)
1. Used to effect setup mode switching.
 2. While the setup mode operation is being conducted, this key functions as the **ENTER** key.

13.3 Operation Mode Structure

13.3.1 Panel Modes

The panel modes are roughly classified into the following three categories.

1. Normal modes
Used to effect film processor operation changeover or confirm or edit setup data.
2. Service mode
Used to clean the film processor.
3. Maintenance mode
Used for film processor tuning and functional testing.

The mode structure is schematized below.

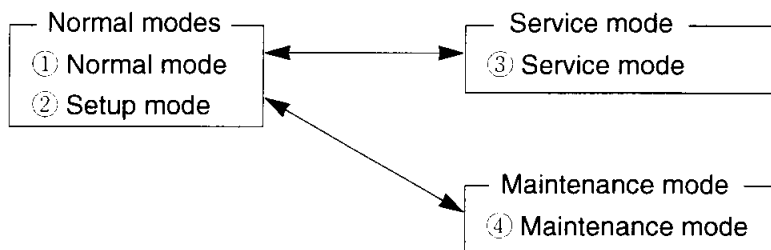

① Normal mode

- Operation ON/OFF changeover at the press of the POWER switch
- Developer/Fixer replenishment and supply
- Alarm buzzer stop and error clearing
- Display Panel (LCD) backlight ON/OFF

② Setup mode

- Processing speed change
- Temperature setup change and measured temperature display
- Replenishment amount setting change
- Weekly timer setup change
- Selftest bypass processing
- Preheat operation
- Accounting of film/clearing data
- Accounting of replenishment/clearing data
- Calender/Clock Setting
- READY status display

③ Service mode (service mode entry is achievable in the "Power ON" period only)

- Water charging
- Circulation
- Drive

④ Maintenance mode (maintenance mode entry is unachievable during film processing)

- Error log display
- Feed sensor voltage display
- Sensor OFF setup
- Sensor status information
- I/O display
- Load independent drive
- Dryer section temperature information
- Temperature correction
- Replenishment pump correction
- LCD backlight setup
- Operating time display/clear
- ROM version display

13.4 Screen Hierarchy

Multiple levels of screens are provided. Top-level screen transitions take place in accordance with the film processor internal process.

13.4.1 Switching from One Screen Level to Another

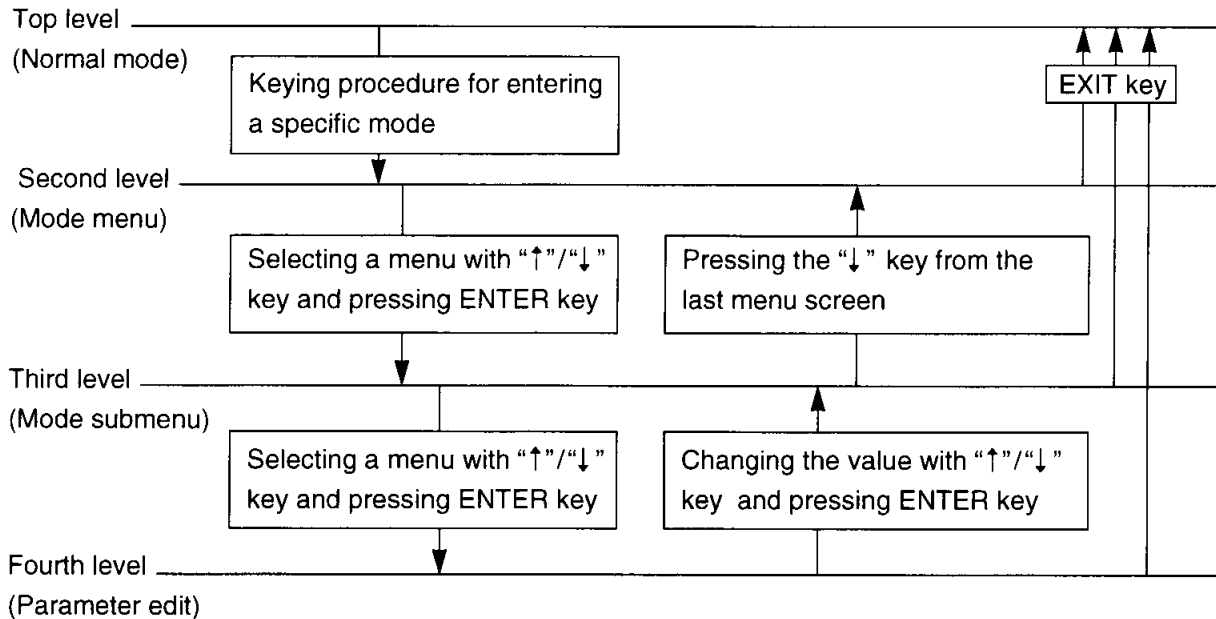

Supplementary explanation of individual levels

- **Top level**
Normal mode screen.
Indicates the film processor operating status.
- **Second level**
Mode menu selection screen.
Shows function menus of individual modes.
Example: Temperature setup, replenishment correction, etc.
- **Third level**
Mode submenu selection screen.
Shows subdivided function menus.
(In the case of some functions, the fourth level appears subsequently to the second level.)
Example: Processing speed setup.
- **Fourth level**
Parameter edit screen.
Used to edit the parameter values displayed by second or third level screens.

13.4.2 Mode Switching Procedures

13.4.2.1 Switching to a Mode Accessible to Users [Setup Mode]

When the MODE key is held down for a period of 3 seconds or longer from a normal screen, the system switches to the setup mode.

* Pressing EXIT key from any screen returns the system to the normal mode.

13.4.2.2 Switching to a Mode Inaccessible to Users 1 [Service Mode]

When the ALARM OFF key is held down for a period of 3 seconds or longer with the MODE key held down from a normal screen, the system switches to the service mode.

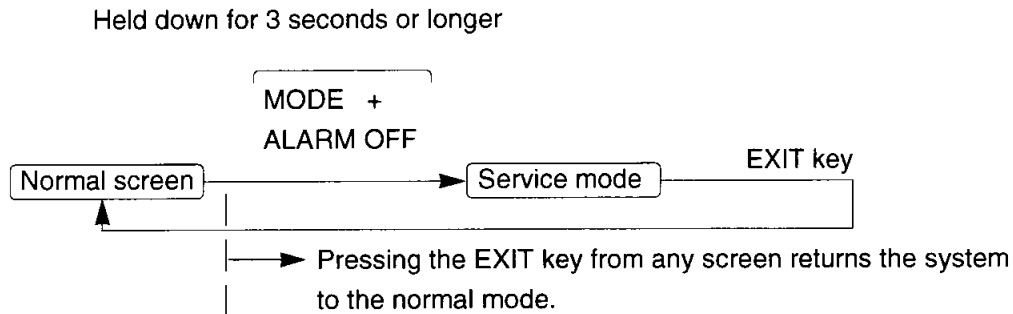

13.4.2.3 Switching to a Mode Inaccessible to Users 2 [Maintenance Mode]

When the LIGHT key is held down for a period of 3 seconds or longer with the MODE key held down from a normal screen, the system switches to the maintenance mode.

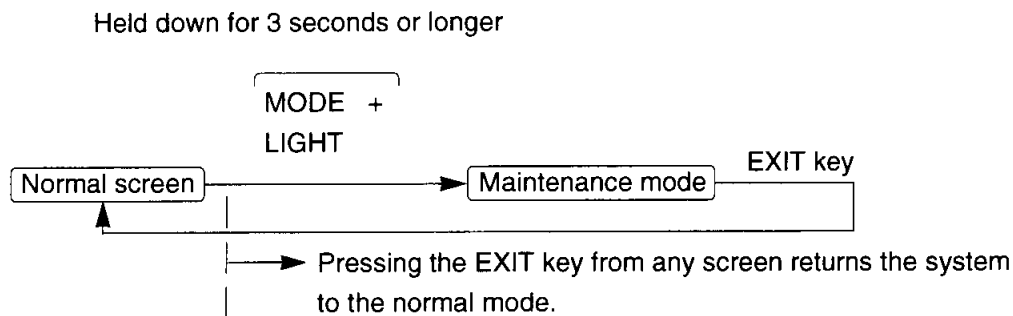

13.4.3 Setting Change Procedure Example (Developer Temperature Setup in Setup Mode)

Third level (submenu) Supplement

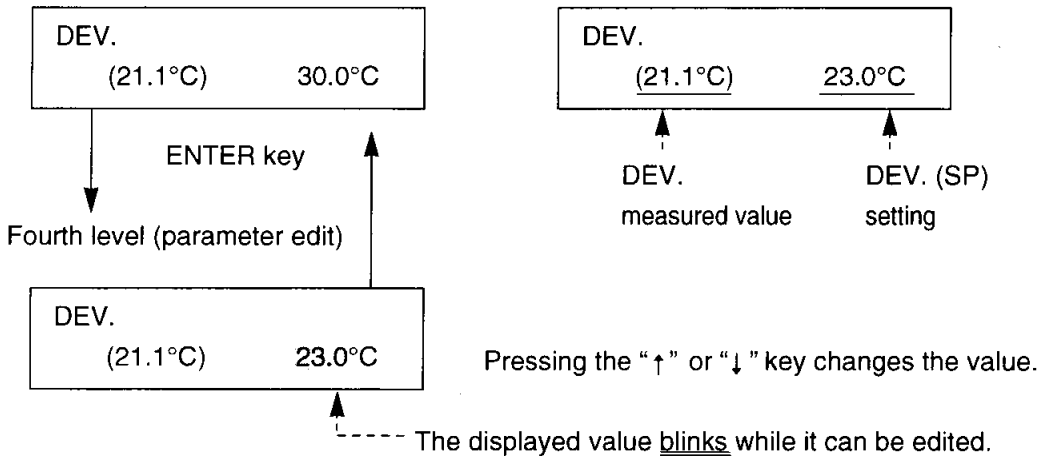

(a) Key definitions

"↑" key :

Increments the blinking data value. When the key is pressed after the upper-limit value is reached, the setting changes to the lower-limit value and is incremented at the press of the "↑" key.

"↓" key :

Decrements the blinking data value. When the key is pressed after the lower-limit value is reached, the setting changes to the upper-limit value and is decremented at the press of the "↓" key.

ENTER key :

Finalizes the value entry or effects screen level changeover.

13.5 Normal Mode

In the normal mode, the display panel shows the film processor status and displays the weekly timer setup, developer solution temperature, and processing speed.

13.5.1 Screen Transition

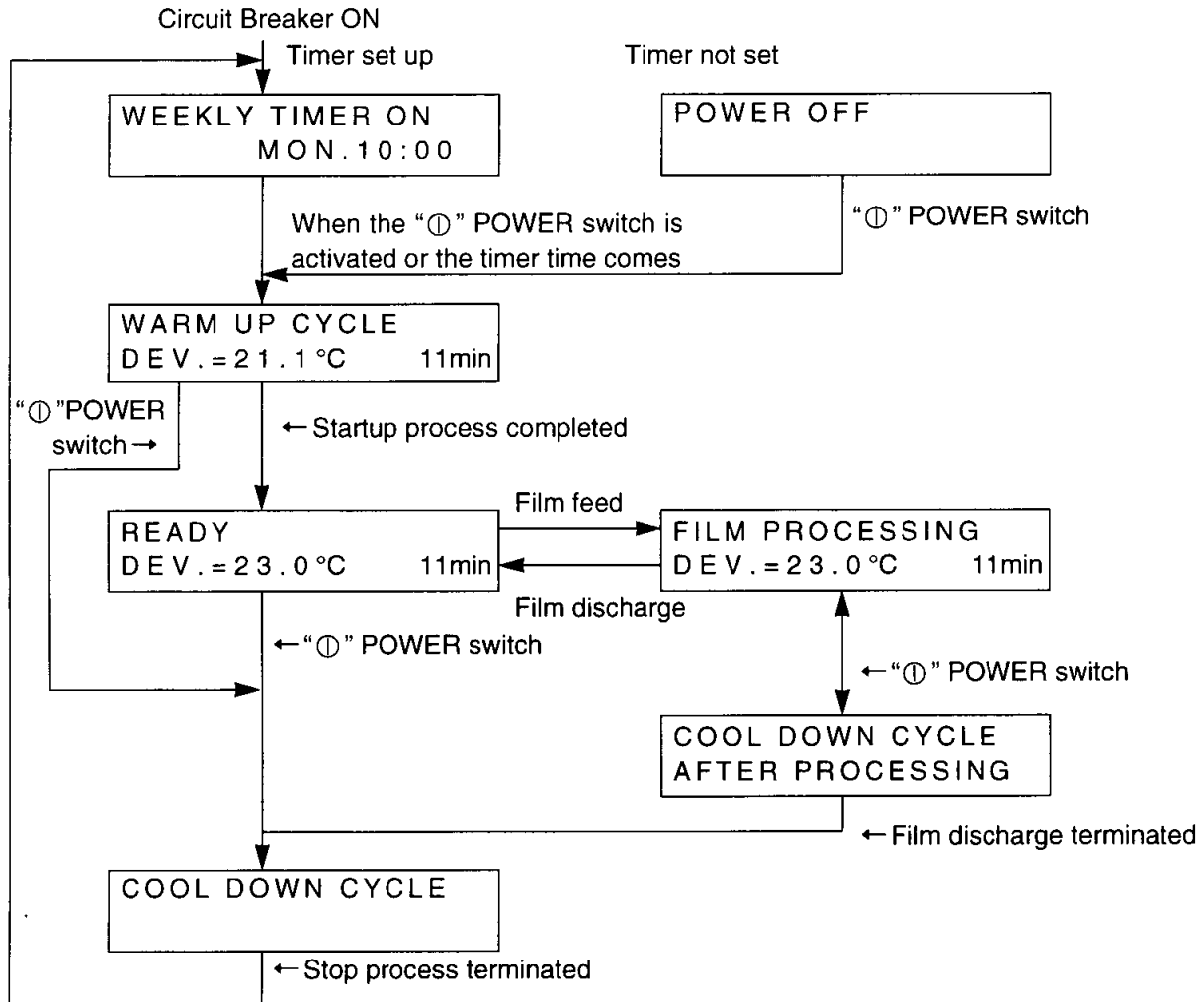

* When the REPL. key is held down for a period of 1 second or longer while a normal mode screen displayed, the system initiates developer/fixer replenishment or supply. When replenishment starts, the system switches to the following screen. When the REPL. key is held down again for a period of 1 second or longer or the replenishment sequence is terminated, the system returns to the film processor status display screen.

Developer/ Fixer replenishment period screen

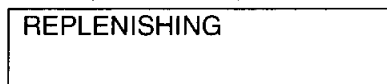

Developer/ Fixer supply period screen



The developer/fixer solution supply function is executed only when the processing tank solution level is too low at the time of "Power ON." In the other situations, the developer/fixer replenishment process is performed instead.

13.5.2 On-screen Information

(1) "Power ON" period screen

While the film processor is inactive, the following is displayed.

Pressing the "⓪" POWER switch causes the system to switch to the "Startup process screen."

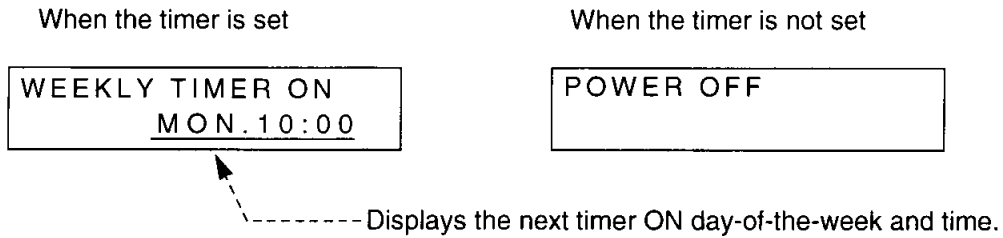

(2) Startup process screen

While the film processor is starting up, the following is displayed.

When the film processor is ready for film processing, the system switches to the "Film processing readiness screen."

Pressing the "⓪" POWER switch causes the system to switch to the "Stop process screen."

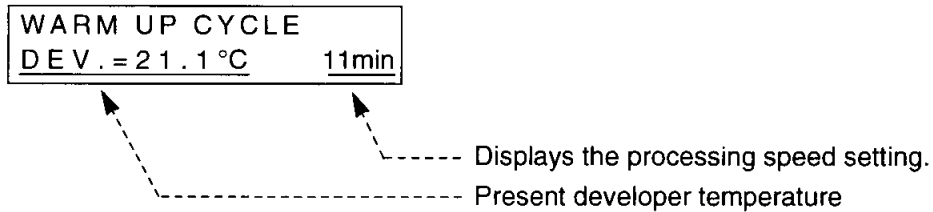

(3) Film processing readiness screen

While the film processor is ready for film processing, the following is displayed.

When film is fed, the system switches to the "Film processing screen."

Pressing the "⓪" POWER switch causes the system to switch to the "Stop process screen."

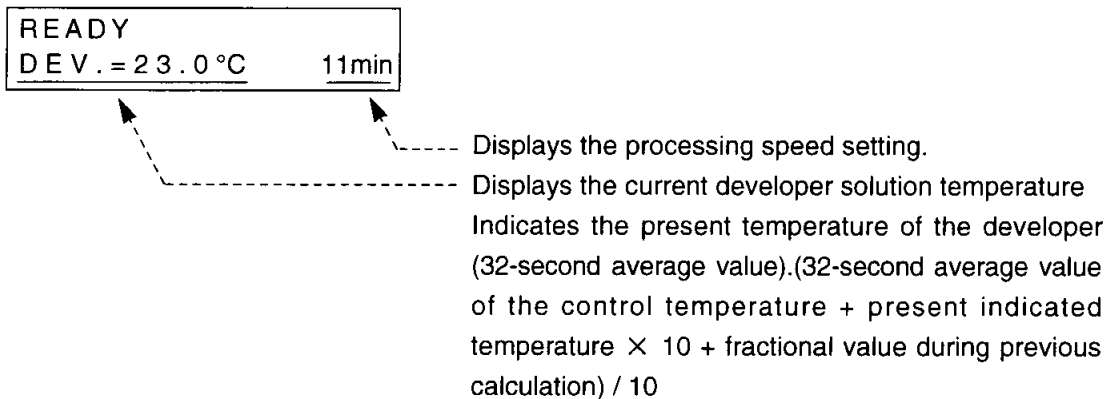

(4) Film processing screen

While the film processor is engaged in film processing, the following is displayed.

When the film discharge drive comes to a stop, the system switches to the "Film processing readiness screen."

Pressing the "⓪" POWER switch causes the system to switch to the "Film discharge completion wait screen."

FILM PROCESSING	
DEV. = 23.0°C	11min

Displays the processing speed setting.

Displays the current developer solution temperature
Indicates the present temperature of the developer
(32-second average value).

(5) Film discharge completion wait screen

While the film processor is waiting for film discharge completion, the following screen is displayed.
(While the following screen is displayed, the system continuously exercises film processing control.)
When the film discharge drive comes to a stop, the system switches to the "Stop process screen."
Pressing the "Ⓜ" POWER switch causes the system to switch to the "Film processing screen."

* Waiting for film discharge completion → Waiting for film discharge completion due to operation OFF during film processing

COOL DOWN CYCLE AFTER PROCESSING

(6) Stop process screen

While the film processor is in the stop process, the following screen is displayed.
When a sequence of stop process operations is completed, the system switches to the "Power ON period screen."
Pressing the "Ⓜ" POWER switch causes the system to switch to the "Startup process screen."

COOL DOWN CYCLE

13.6 Setup Mode

In the setup mode, the settings can be edited or confirmed.

Pressing the EXIT key in the setup mode returns the system to a normal screen.

13.6.1 Setting Adjustment Range for Setup Mode (Tentative)

Item	Processing Speed	Adjustment range	Resolution	Initial Value	Unit	
Speed		DipSW		Adjustment range	Initial Value	
		1-5	1-6			
		OFF	OFF	5min, 11min	5min	
		ON	ON			
		ON	OFF	9min, 13min	9min	
OFF	ON	5min, 9min	5min			
Temperature	Developer	5min	25.0~35.0	0.1	30.0	
		9min				
		11min				17.0~32.0
		13min				22.0~32.0
	Fixer	5min	29.0~34.0	1.0	31.0	
		9min				
		11min				
		13min				
	Main	5min	30.0~50.0	1.0	50.0	
		9min			40.0	
		11min			40.0	
		13min			42.0	
		Stand by lower limit	5min	25.0~35.0	1.0	35.0
			9min			30.0
			11min			25.0
			13min			30.0
Replenishment Rate	Developer	5min	0,30~150	5	100	
		9min				
		11min				
		13min				
	Fixer	5min	0,70~300	5	300	
		9min	0,60~240		200	
		11min	0,70~300		300	
		13min	0,60~240		200	
Weekly timer		0 : 00~23 : 59 -- : --	1 min	-- : -- OFF		
DATE & TIME		1999~2098 1/1~12/31 0 : 00~23 : 59				

13.6.2 Setup Mode Screen Transition

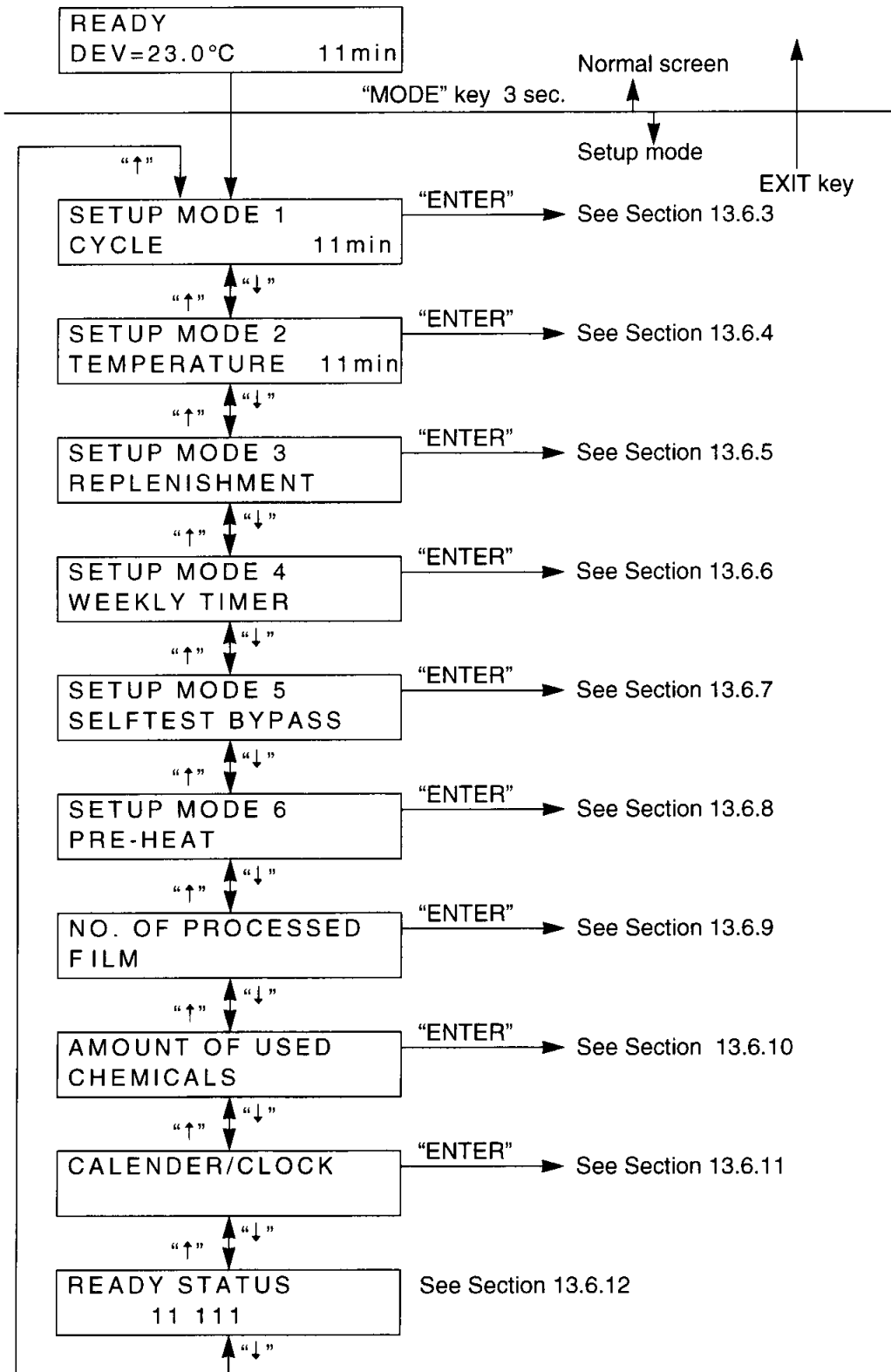

13.6.3 Speed Setup

The film processing speed (11min/5min) can be set up.



The processing speed selection toggles between 11min and 5min at each press of the “↑” / “↓” key. The selection is finalized at the press of the ENTER key. However, if the processing speed selection is changed during film processing, selftest bypass processing, or transport start signal ON period, the speed change takes effect after the motor stops.

13.6.4 Temperature Setup

The developer, fixer, and dryer temperature settings for the selected processing speed can be set up.

* The menu changes as needed to match the processing speed selection. (When 11min is selected, only the 11min temperatures can be set up.)

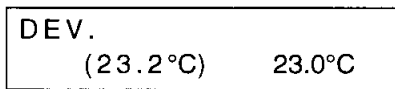

Temperature setting
(While the setting is blinking, it can be changed by pressing the “↑” / “↓” key and finalized by pressing the ENTER key.)

Measured temperature

When the processing speed is 11min

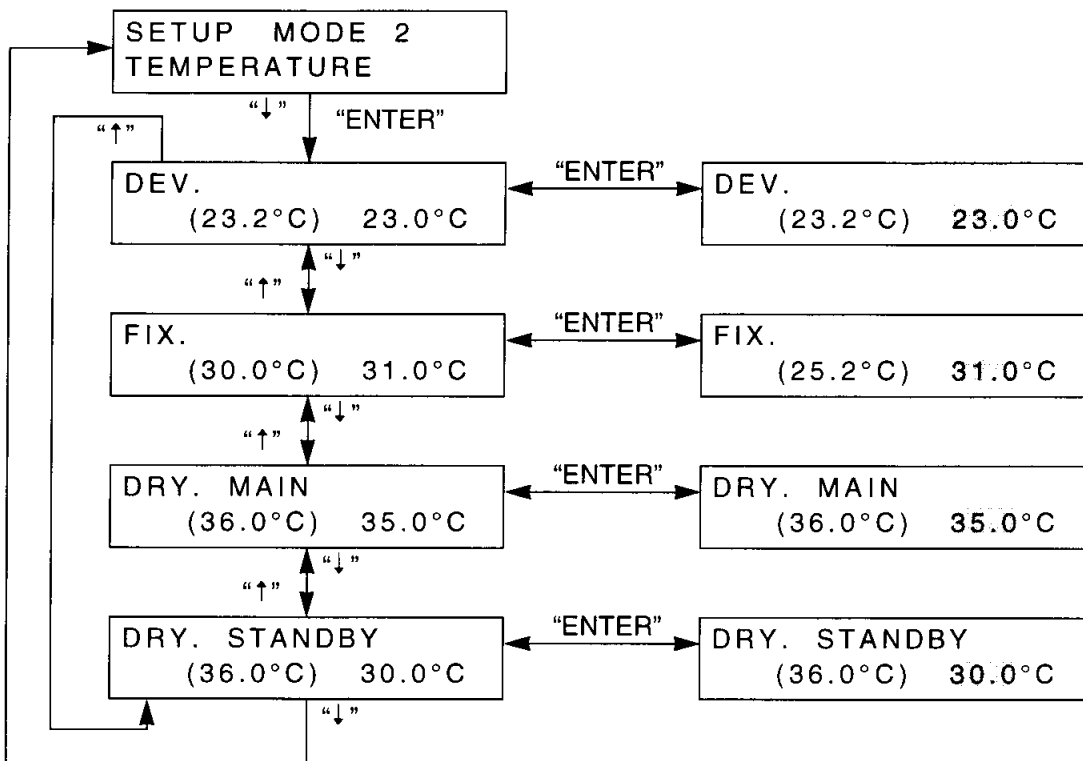

13.6.5 Replenishment Rate Setting

Replenishment rate for 1 sheet of 14 × 17 inches.

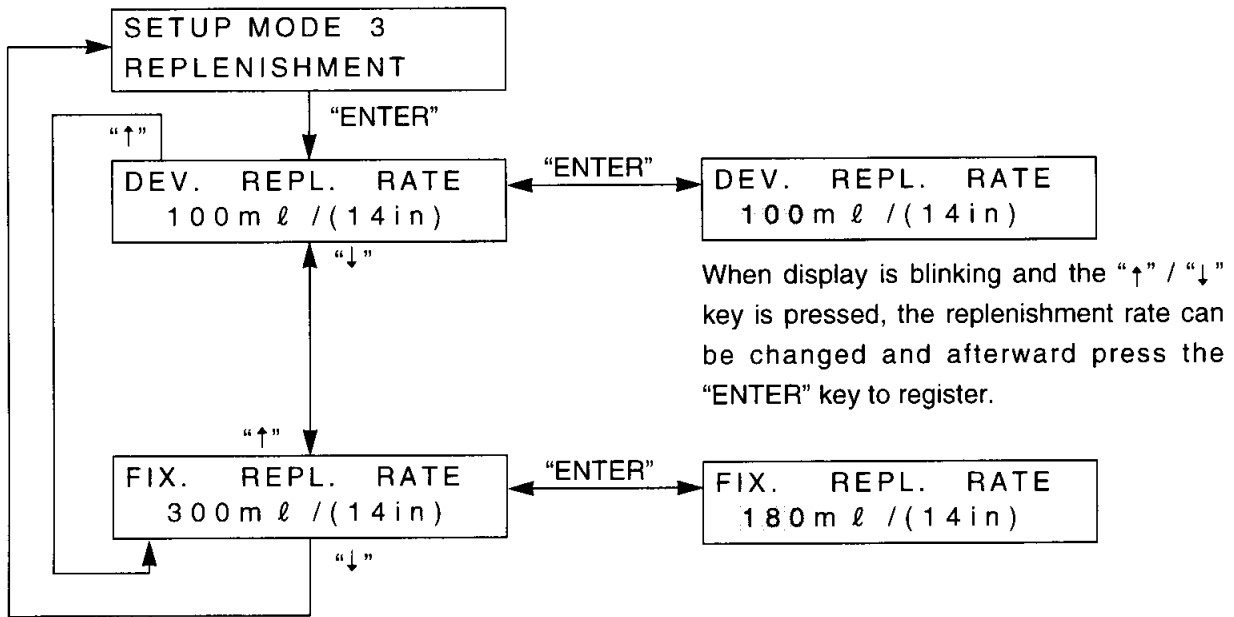
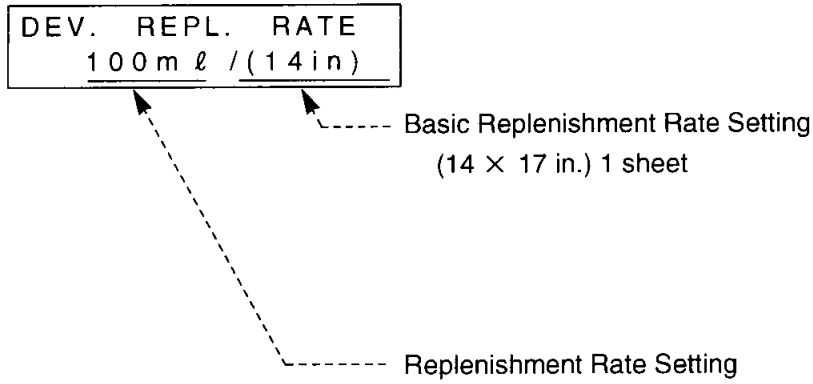

13.6.6 Weekly Timer Setting

When the weekly timer has been set up, the FIP7000 starts up and shuts down automatically at the preset time. (One ON/OFF cycle per day)

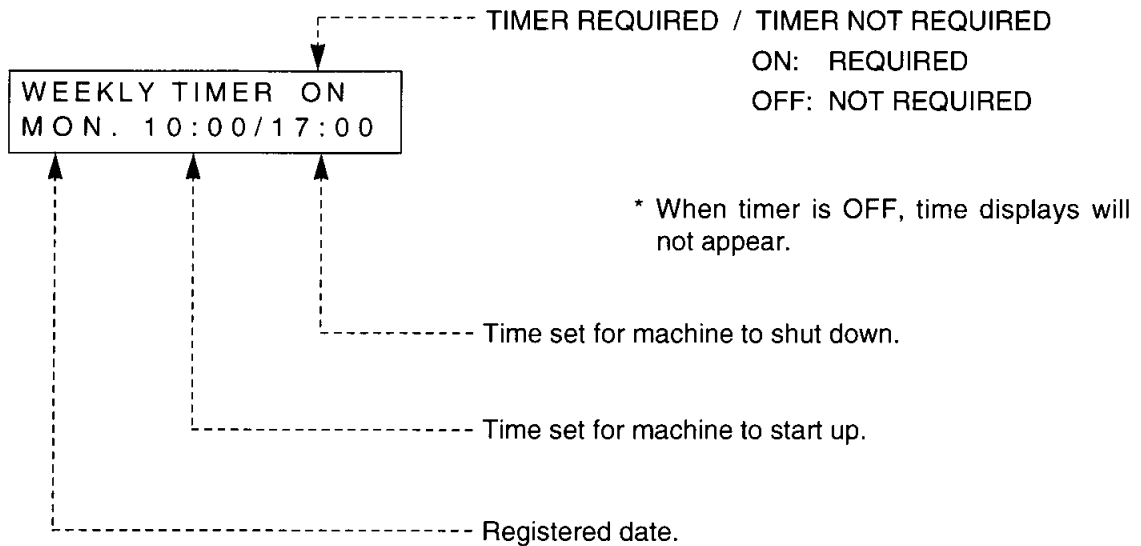

NOTE 1: When the "--:--," registers, machine will not function.

NOTE 2: When timer for functioning and to stop is set for the same time, machine will not function.

When the "ENTER" key is pressed, the following setup sequence will appear:

- ① TIMER ON/OFF
- ② ON TIME SETTING
- ③ ON MINUTE SETTING
- ④ OFF TIME SETTING
- ⑤ OFF MINUTE SETTING

13.6.6.1 Change of Time ON Timer

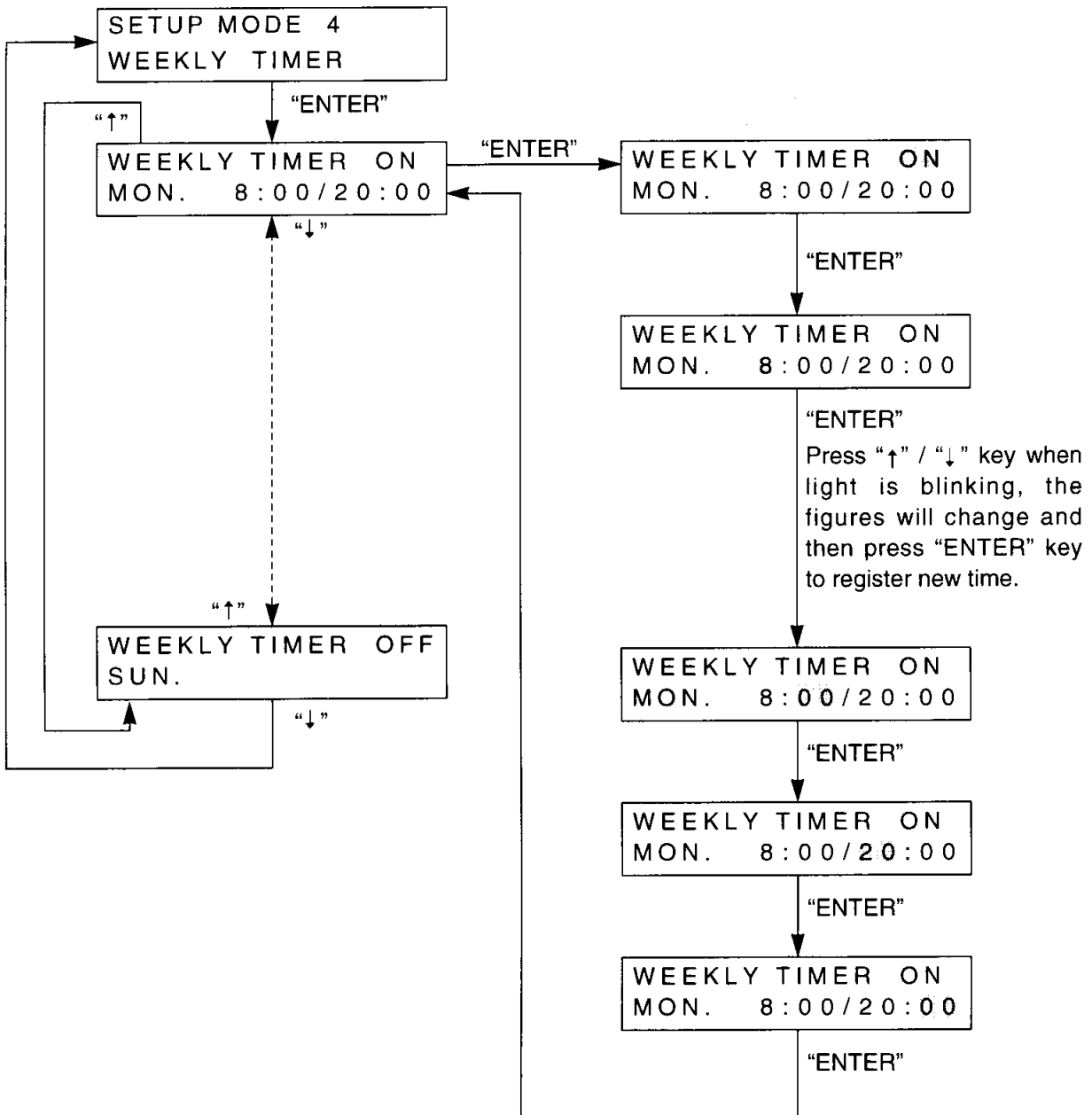

13.6.6.2 Changing from OFF to ON

Nothing will be registered when the machine is OFF.

When the machine is switched from OFF to ON, the weekly time registered previously will appear on display.

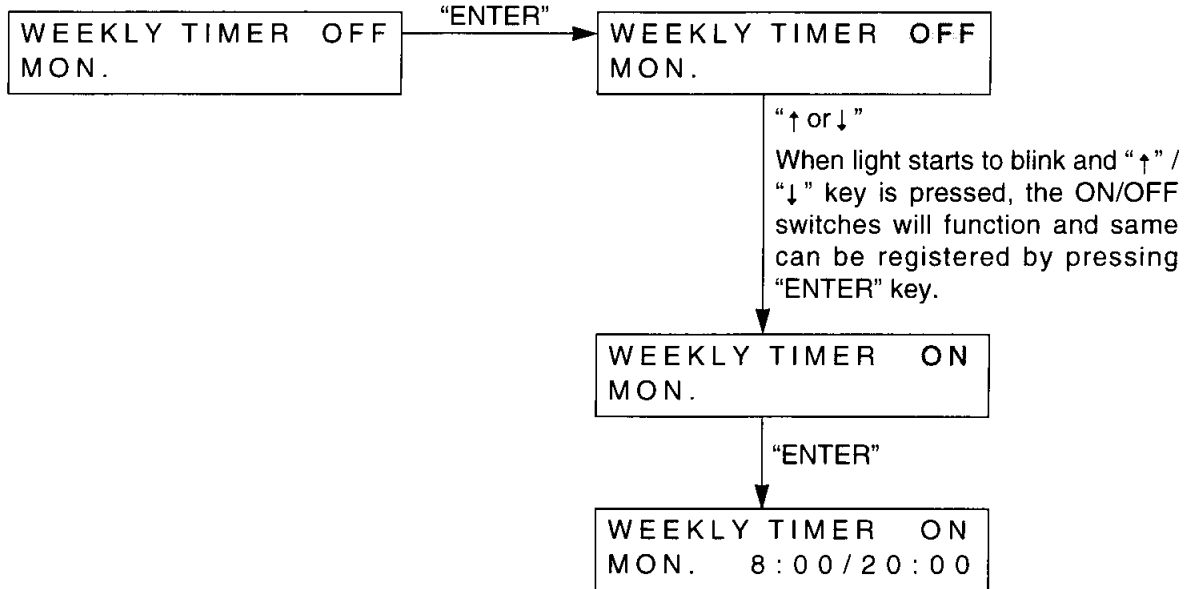

13.6.6.3 Changing from ON to OFF

Nothing will be registered when the machine is OFF. When the machine is switched from ON to OFF, the set time for weekly timer will not be appeared on display.

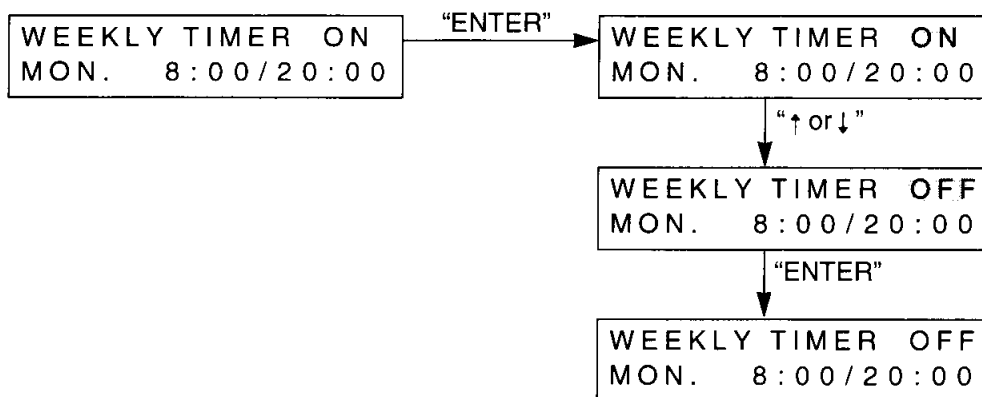

13.6.7 Selftest Bypass Setting

If emergency film processing is necessary in the event of processor trouble, the film can be processed by selftest bypass processing.

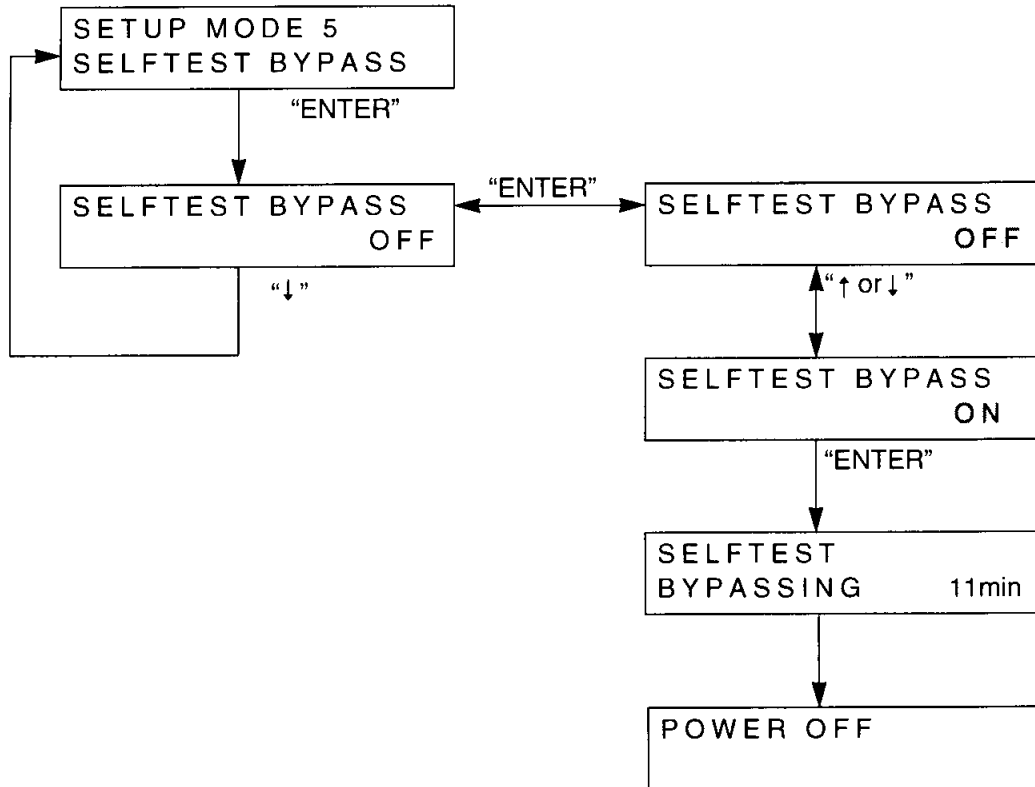

13.6.8 Preheat Mode Setting

When the preheat mode is selected, the FIP7000 will maintain only developer and fixer temperatures within certain ranges while saving energy. This mode is ideal for emergency use.

Press the power switch to enter the regular cycle.

When the PREHEAT mode is selected and the weekly timer is set, the FIP7000 will automatically turn on to the regular mode.

If the PREHEAT mode is selected and the weekly timer OFF is set, the FIP7000 will ignore the weekly timer OFF.

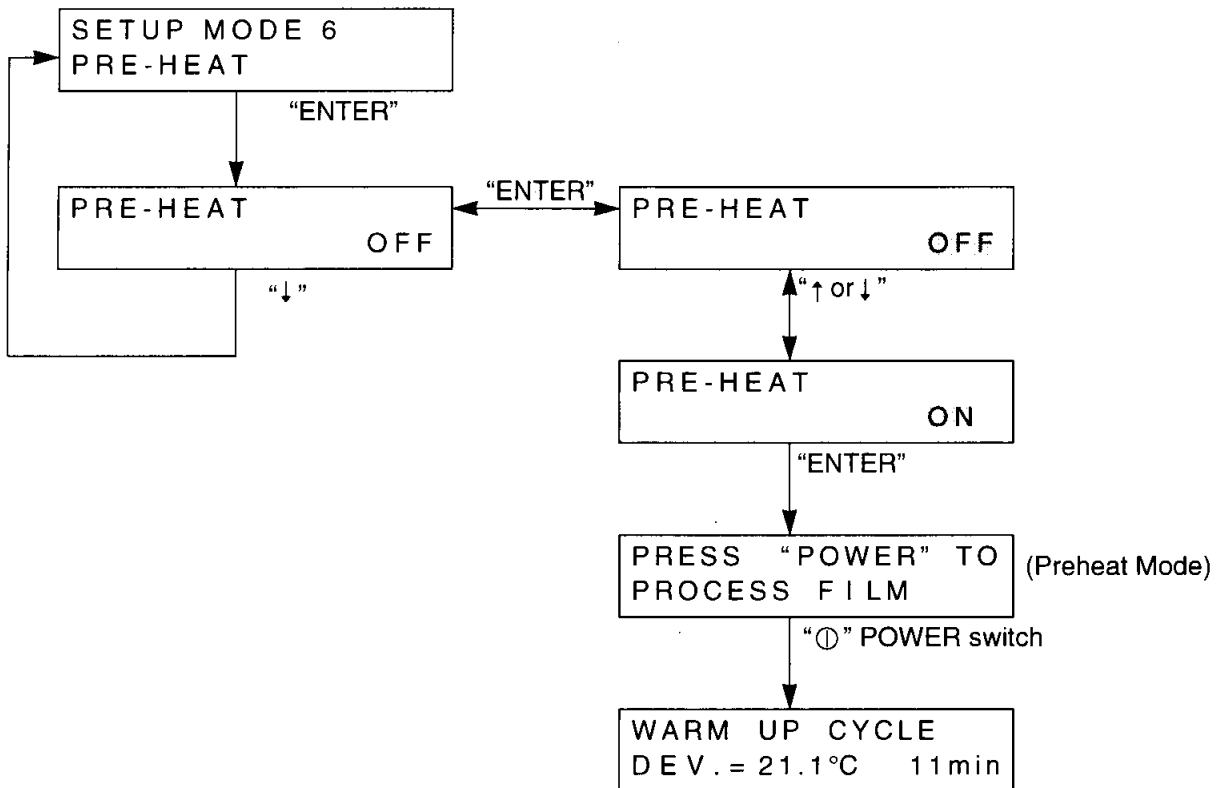

13.6.9 Accounting of Films/Clearing Data

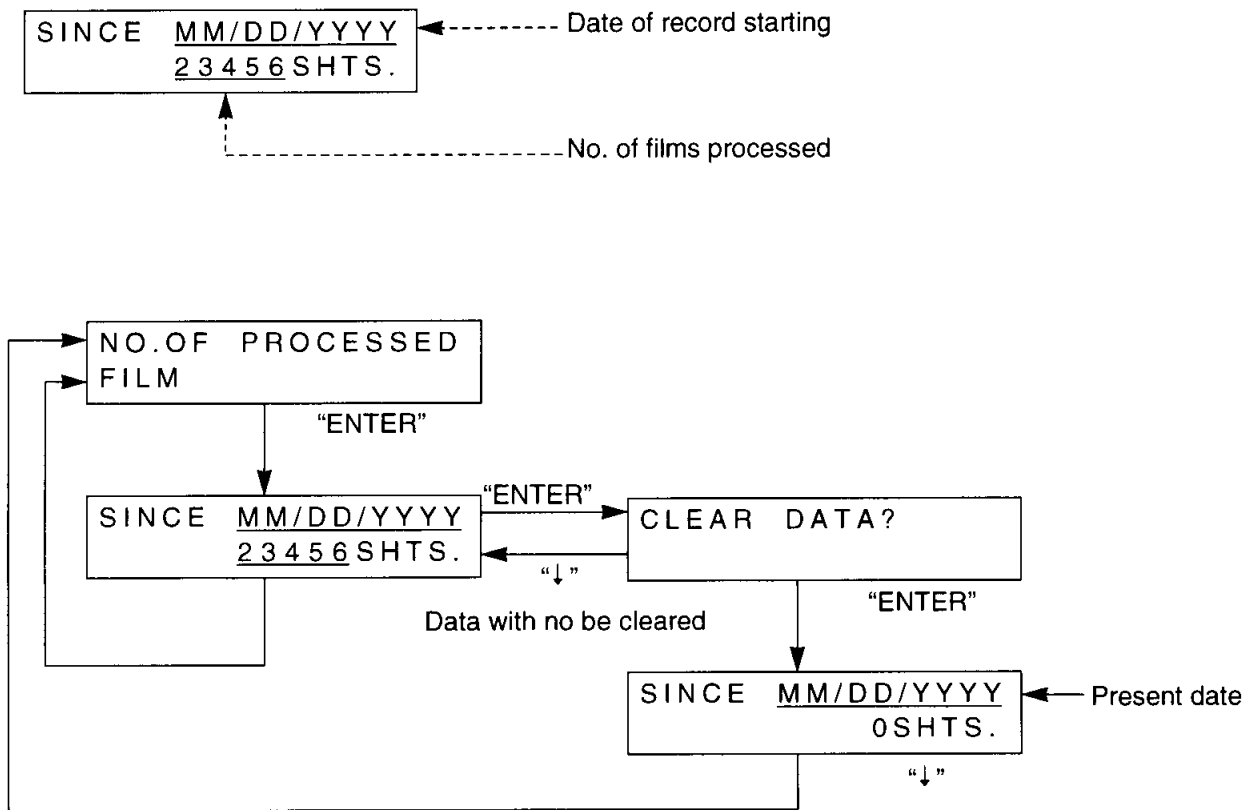

Number of films used can be accounted for and used data can also be cleared.

NOTE 1: Maximum number of films can be accounted up to 99999.

When accounting exceeds 99999, the next count will begin from "0".

NOTE 2: When the display shows "CLEAR DATA" and then "ENTER" key is pressed, the number of films processed so far are cleared and the display shows the present date.

NOTE 3: Data display has two different way, MM/DD/YYYY or DD/MM/YYYY.

13.6.10 Accounting of Replenishment/Clearing Data

Volume of replenishment can be accounted for and used data can also be cleared.

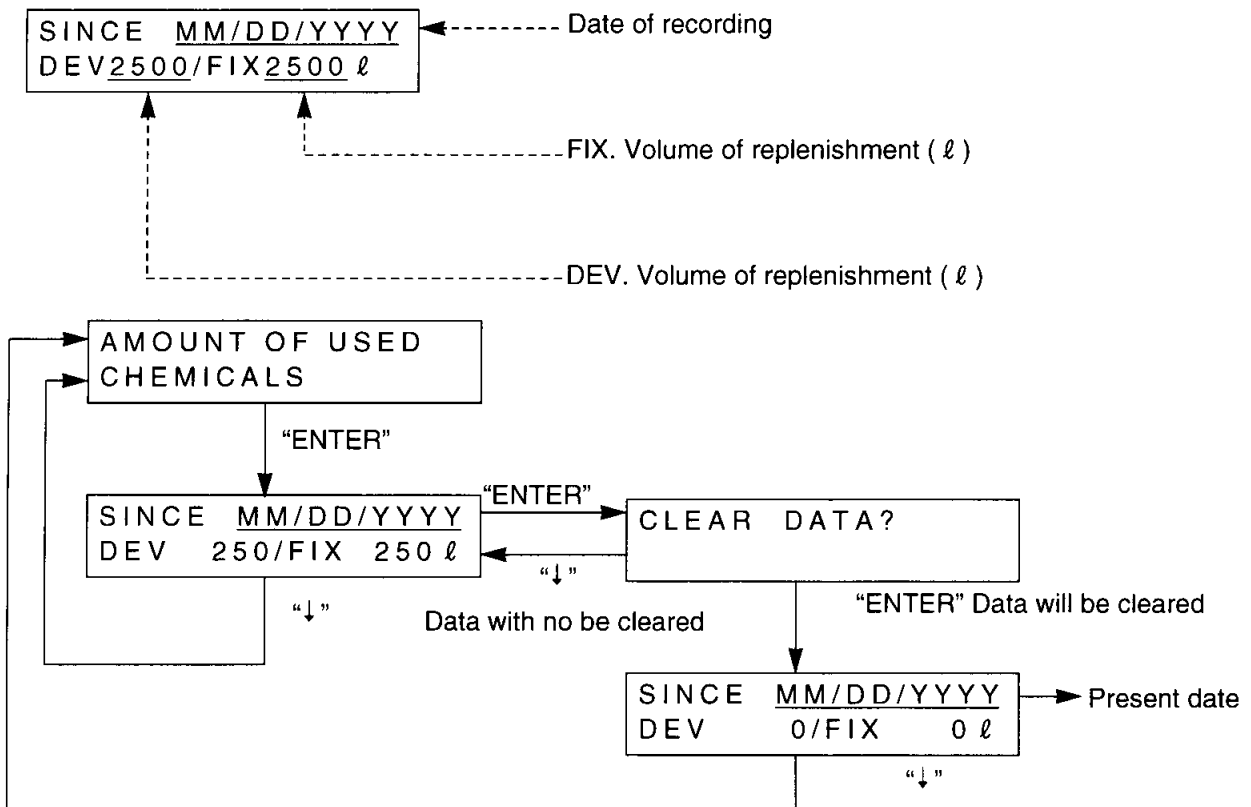

NOTE 1: Maximum accounting of replenishment will be 9999 l . When accounting exceeds 9999, the next count will begin from "0".

NOTE 2: When amount of replenishment is more than 500 l display will register this as 1 liter.
ex. (If replenishment is 500 ml display will register this as 1 l)

NOTE 3: When the display shows "CLEAR DATA" and then "ENTER" key is pressed, the volume of accounted replenishment so far are cleared and the display shows the present date.

13.6.11 Calendar/Clock Setting

The current date and time of day can be set (or modified) by this setting. The CALENDAR display varies depending on the state of DIP SW1-2.

DIP SW1-2 OFF: MM/DD/YYYY

DIP SW1-2 ON: DD/MM/YYYY

The following is an explanation for DIP SW1-2 OFF.

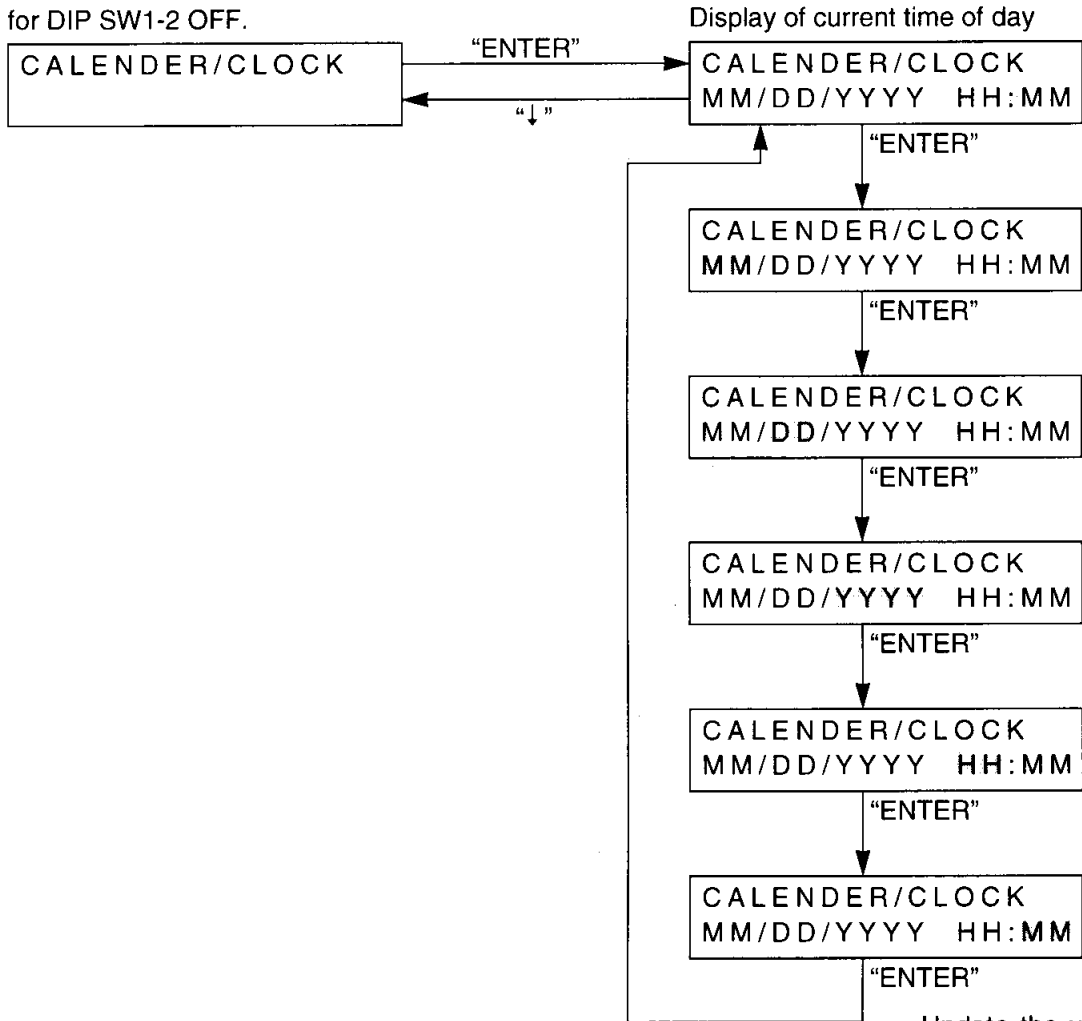

While blinking, the numerical value can be changed by pressing the "↑" / "↓" keys.

Update the year, month, day, hour, minutes, seconds (=0).

* If the day (DD) goes beyond the allowed range at the time the year (YYYY) is confirmed, the maximum day of the month is used.

(Example) 2/31/2001 → 2/28/2001

13.6.12 Ready Status

Checking can be made to see if all conditions of machine are in a ready position.

READY STATUS 1 1 1 1 1

READY STATUS (from the left)

- ① Film interval [When the film is feeding, this is change to 0]
- ② Error [When the error is occurred, this status is changed to 0]
- ③ Temperature of Developer
- ④ Temperature of Fixer
- ⑤ Temperature of Dryer

* Display

1: READY STATUS

0: NOT READY STATUS



13.7 Service Mode

In the service mode, various loads can be operated on an individual basis for film processing cleaning purposes.

Pressing the EXIT key in the service mode causes the system to bring all the currently executed functions to an automatic stop and return to a normal screen.

13.7.1 Service Mode Screen Transition

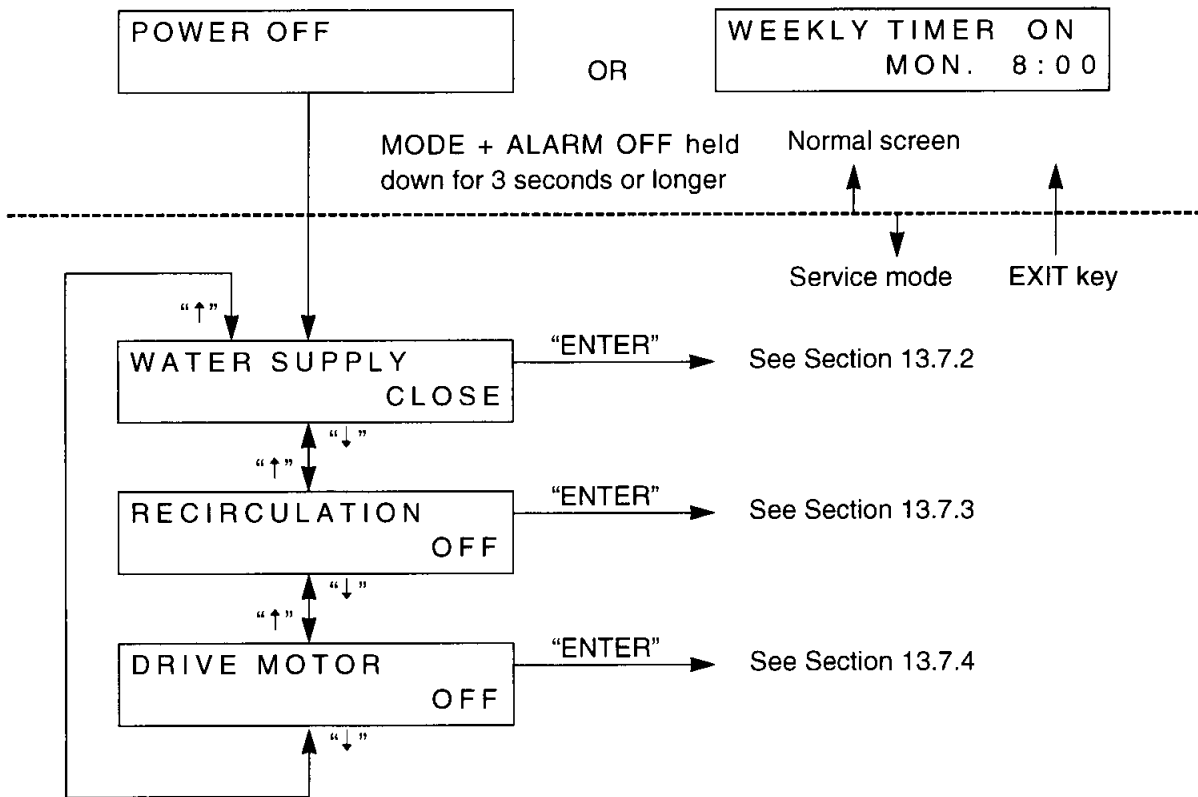

13.7.2 Water Supply

This function is used to turn ON and OFF the water supply solenoid valve.

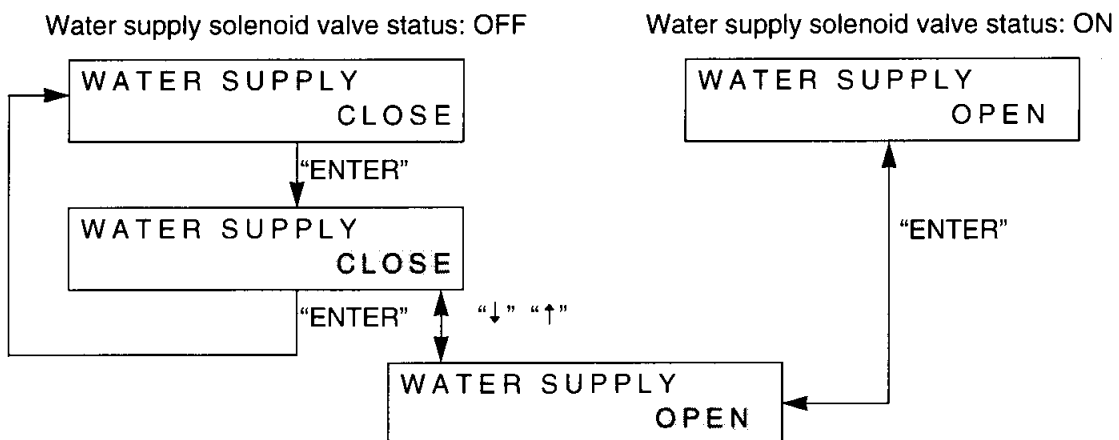

13.7.3 Drive Motor

This function is used to turn ON and OFF the drive motor.

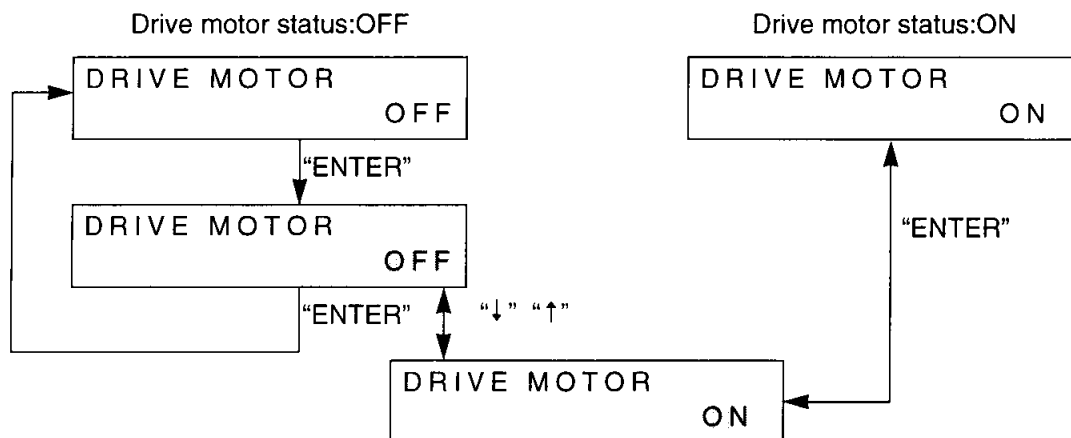

13.8 Maintenance Mode

In the maintenance mode, it is possible to check the setup performed at installation or the internal operating status of the film processor.

When the EXIT key is pressed in the maintenance mode, the system automatically stops the currently executed loads and returns to a Normal Screen.

13.8.1 Setting adjustment Range for Maintenance Mode

		Item	range	Resolution	Intial Value	Unit
Temperature Adjustment	Board	DEV	-4.0~+4.0	0.1	0.0	℃
		FIX				
		DRY				
	Thermistor	DEV	-4.0~+4.0			
		FIX				
		DRY				
Replenishment Adjustment	DEV Repl Pump	60~175	100	ml		
	FIX Repl Pump	180~525	300			

13.8.2 Maintenance Mode Screen Transition

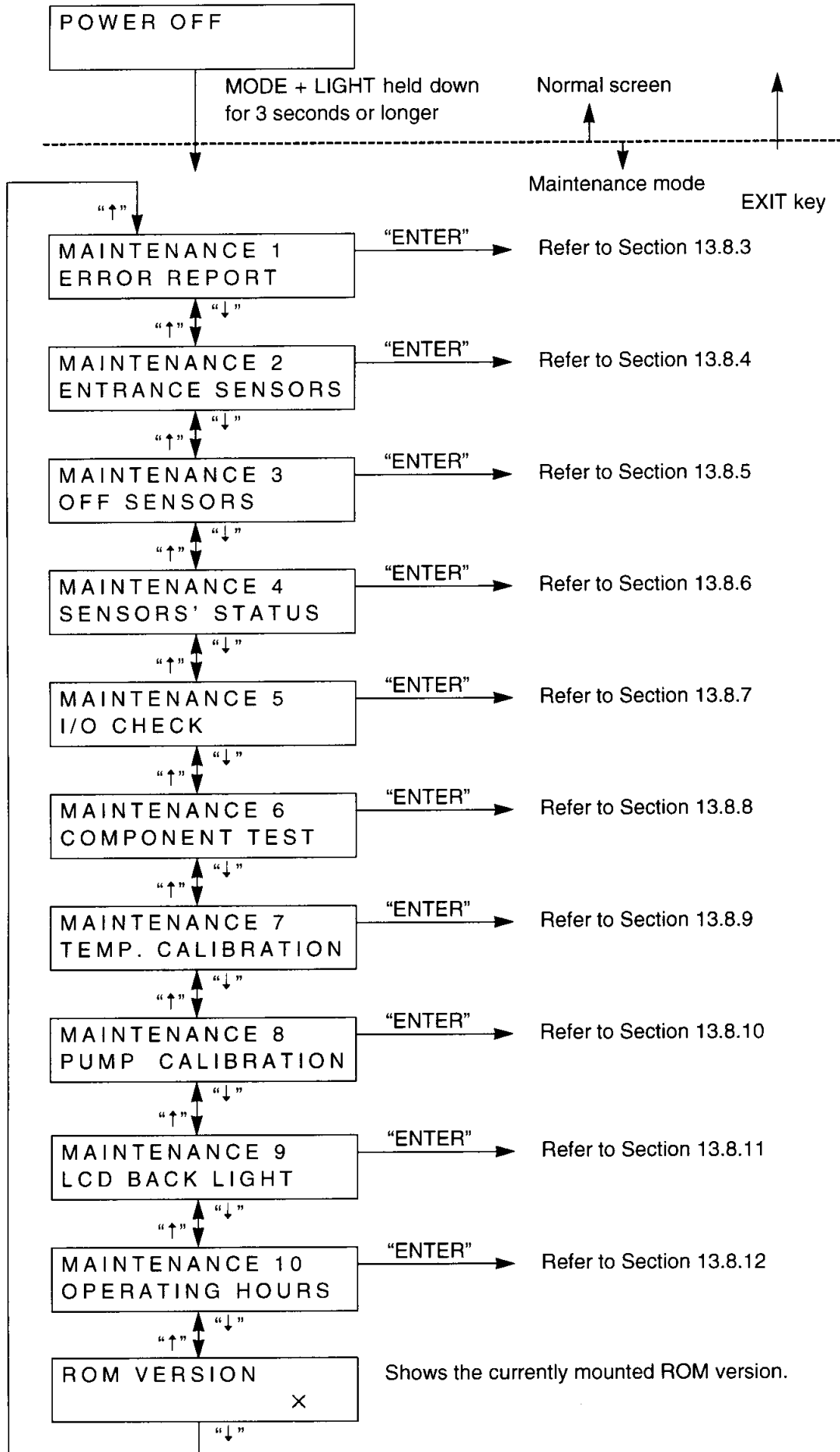

13.8.3 Error Log Display

This function is used to display the 32 latest error event information (error number and occurrence date/time).

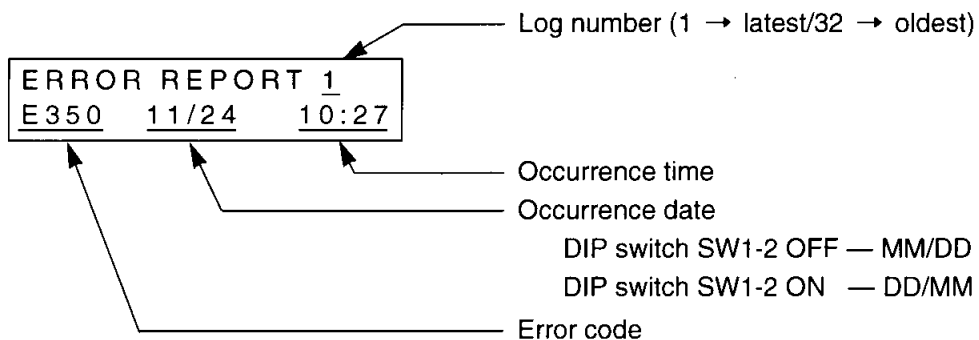

When DIP switch SW1-2 is OFF

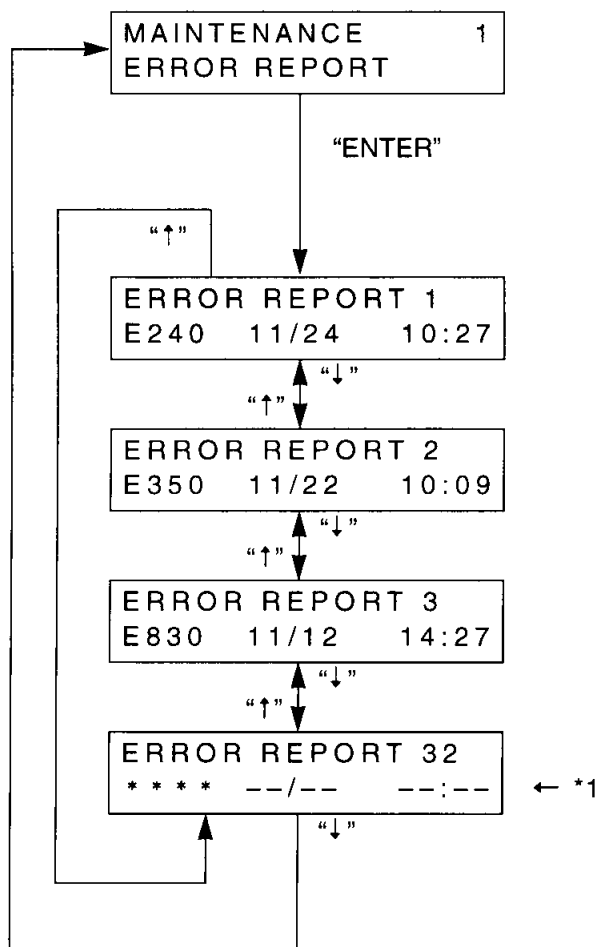

*1 When no data exists, the error number field reads * * * * ,
the date field reads --/--, and the time field reads --:--.

13.8.4 Feed Sensor Voltage Display

This function is used to check the voltage of each feed sensor.

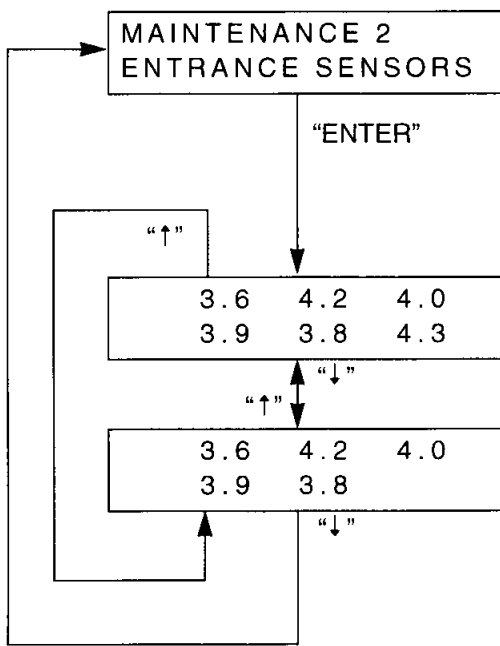
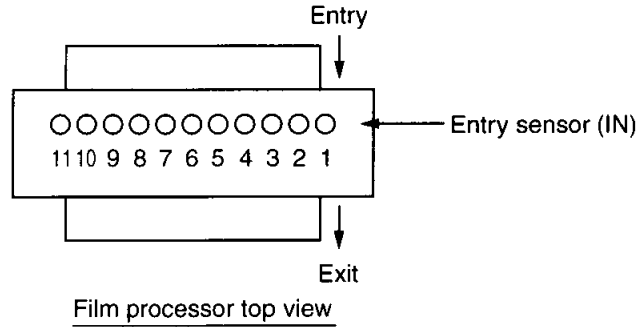

Displays the voltages of feed sensors 1 through 6. (In the upper line from left to right, sensors are designated 1, 2, and 3, and in the lower line, sensors are designated 4, 5, and 6.)

Displays the voltages of feed sensors 7 through 11. (In the upper line from left to right, sensors are designated 7, 8, and 9, and in the lower line, sensors are designated 10 and 11.)

[Determining the voltage]

The feed sensor voltage value is considered to be "V."

Feed sensor AD value: $V = 255:4.64$

Thus

$$V = (4.64/255) \times \text{feed sensor AD value}$$

$$= (\text{feed sensor AD value})/51$$

* The value is updated at 1.2 to 2.0 second intervals.

1 V or higher — Film present.

Lower than 1 V — No film present.

13.8.5 Sensor OFF Setup

This function is used to perform sensor OFF setup for various input sensors.

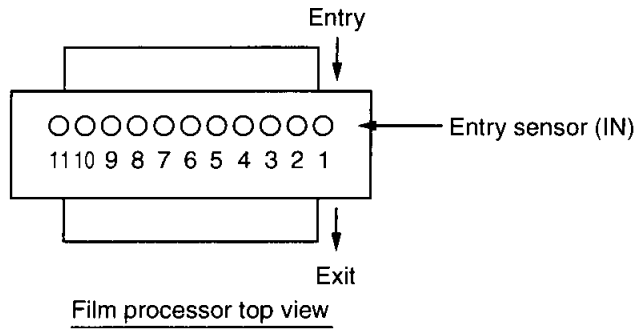

Displayed information

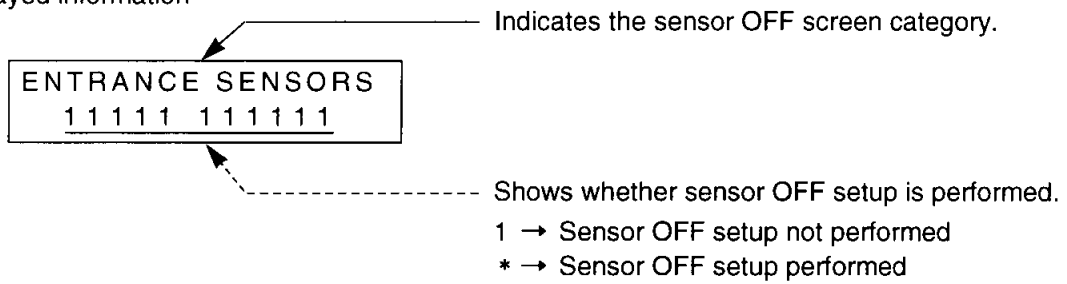

Sensor OFF setup menu

- ① Edit target → Blinking/Other → Steadily glowing

Pressing the ENTER key moves the target one position to the right. Use the “↑” / “↓” key to change the setting.

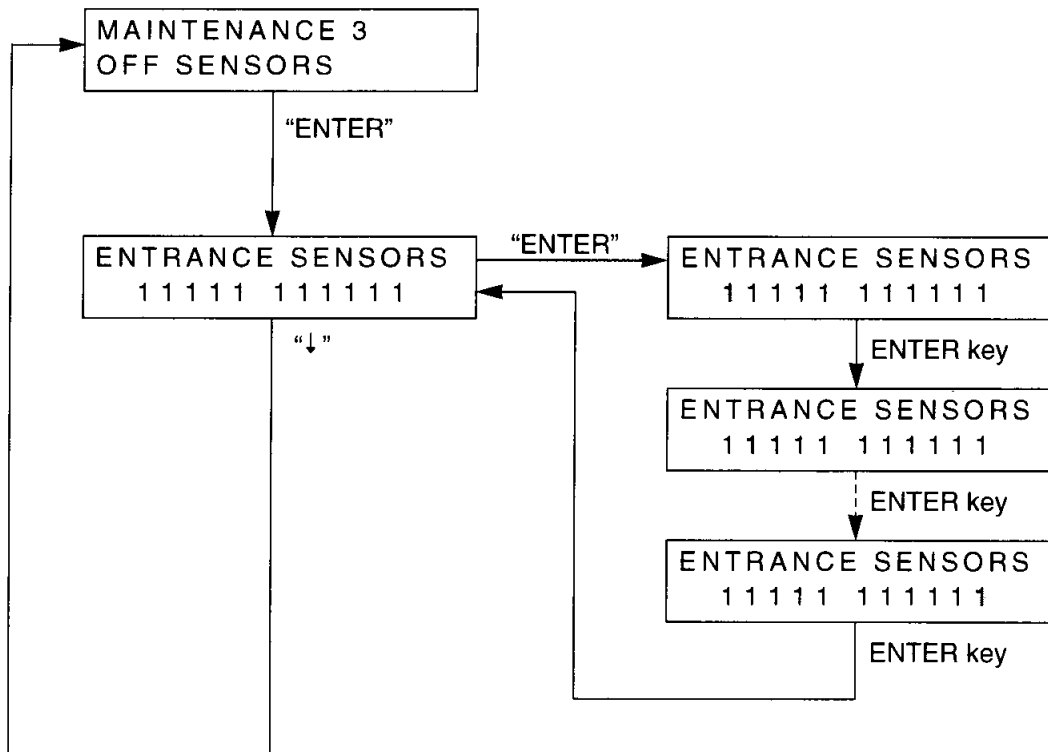

13.8.6 Sensor Status Information

With this function, it is possible to view the feed sensor detection information in real time

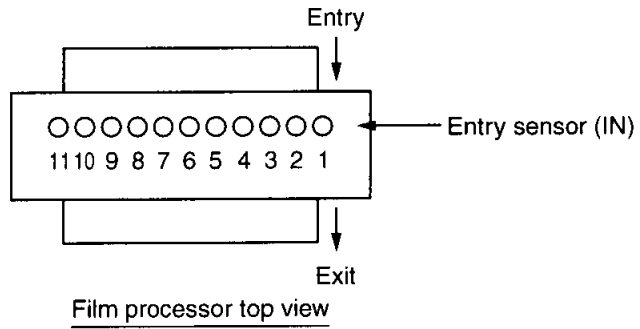

Displayed information

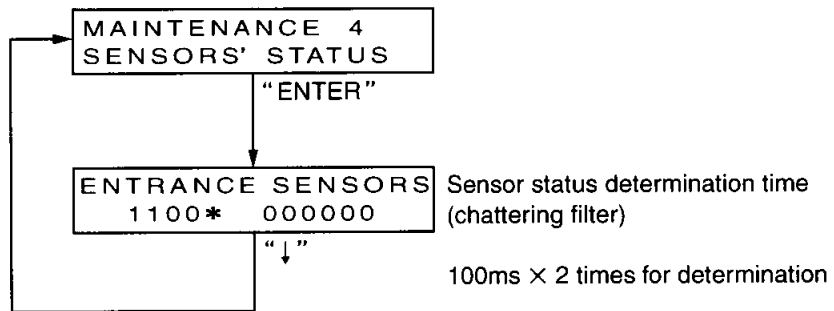
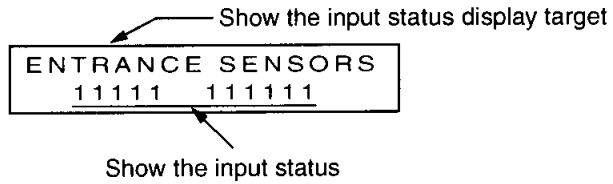

13.8.7 I/O Display

This function is used to view the I/O (PPI input/output) status in real time.

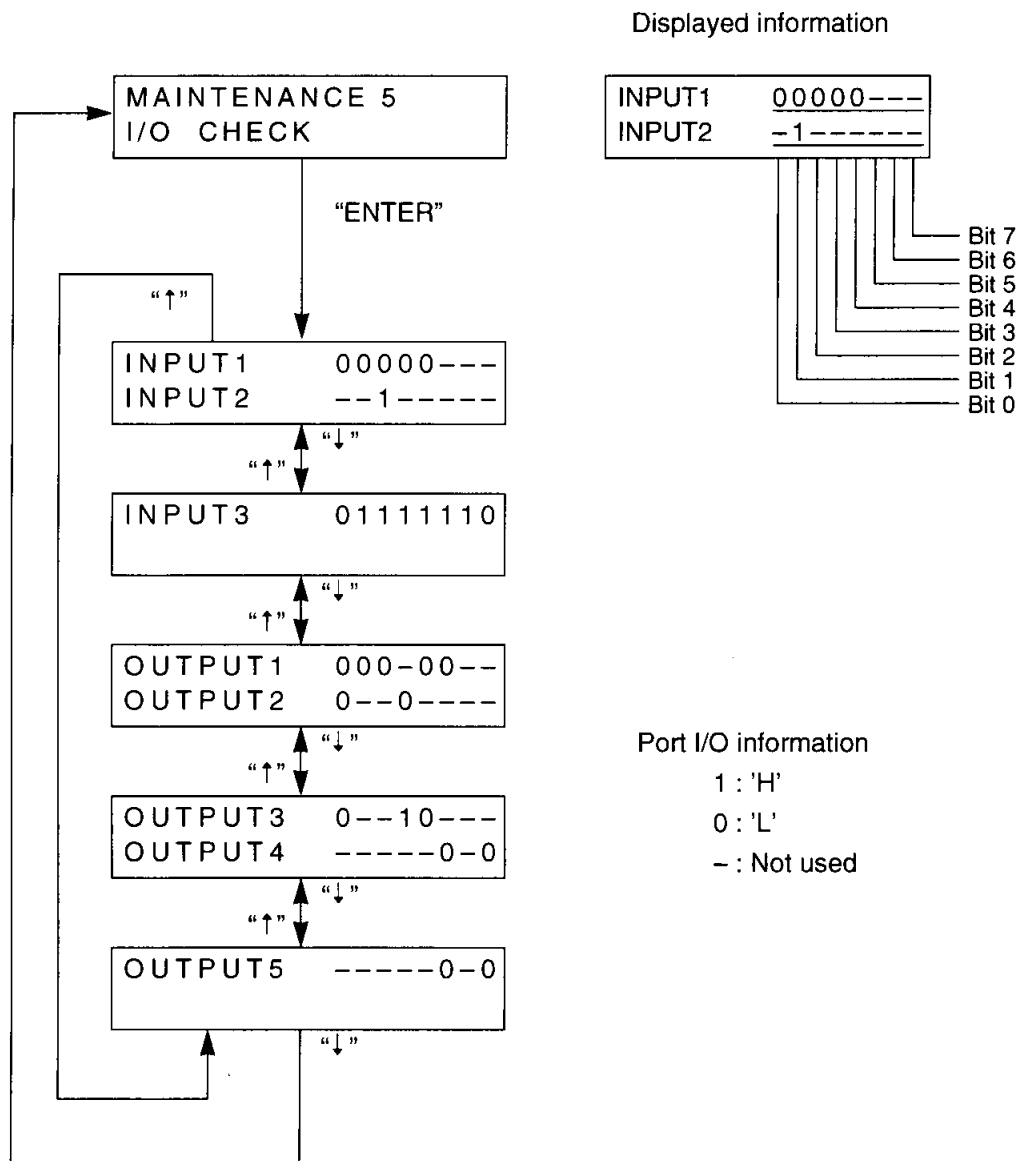

* For the relationship between ports and I/Os, see section 13.8.7.1
The values are updated at about 1-second intervals.

13.8.7.1 Relationship between I/O Display Menus and I/O Devices

Screen	Bit	1	0
INPUT 1	0	The MODE key is pressed.	The MODE key is not pressed.
	1	The REPL. key is pressed.	The REPL. key is not pressed.
	2	The ALARM OFF key is pressed.	The ALARM OFF key is not pressed.
	3	The LIGHT key is pressed.	The LIGHT key is not pressed.
	4	The "Ⓟ" POWER switch is pressed.	The "Ⓟ" POWER switch is not pressed.
	5	—	—
	6	—	—
	7	—	—

Screen	Bit	1	0
INPUT 2	0	—	—
	1	—	—
	2	The top cover is open.	The top cover is closed.
	3	—	—
	4	—	—
	5	—	—
	6	—	—
	7	—	—

Screen	Bit	1	0
INPUT 3	0	DIPSW1-1 OFF	DIPSW1-1 ON
	1	DIPSW1-2 OFF	DIPSW1-2 ON
	2	DIPSW1-3 OFF	DIPSW1-3 ON
	3	DIPSW1-4 OFF	DIPSW1-4 ON
	4	DIPSW1-5 OFF	DIPSW1-5 ON
	5	DIPSW1-6 OFF	DIPSW1-6 ON
	6	DIPSW1-7 OFF	DIPSW1-7 ON
	7	DIPSW1-8 OFF	DIPSW1-8 ON

Screen	Bit	1	0
OUTPUT 1	0	The developer heater is ON.	The developer heater is OFF.
	1	The fixer heater is ON.	The fixer heater is OFF.
	2	Dryer heater 1-3 is ON.	Dryer heater 1-3 is OFF.
	3	—	—
	4	The dryer fan is ON.	The dryer fan is OFF.
	5	The developer pump & The fixer pump is rotating.	The developer pump & The fixer pump is stopped.
	6	—	—
	7	—	—

Screen	Bit	1	0
OUTPUT 2	0	The developer pump is rotating.	The developer pump is stopped.
	1	—	—
	2	—	—
	3	The fixer pump is rotating.	The fixer pump is stopped.
	4	—	—
	5	—	—
	6	—	—
	7	—	—

Screen	Bit	1	0
OUTPUT 3	0	The feed side ALARM buzzer is sounding.	The feed side ALARM buzzer is not sounding.
	1	—	—
	2	—	—
	3	The display panel (LCD) backlight is ON.	The display panel (LCD) backlight is OFF.
	4	The wash water solenoid valve is open.	The wash water solenoid valve is closed.
	5	—	—
	6	—	—
	7	—	—

Screen	Bit	1	0
OUTPUT 4	0	—	—
	1	—	—
	2	—	—
	3	—	—
	4	—	—
	5	The READY LED is illuminated.	The READY LED is extinguished.
	6	—	—
	7	The POWER LED is illuminated.	The POWER LED is extinguished.

Screen	Bit	1	0
OUTPUT 5	0	—	—
	1	—	—
	2	—	—
	3	—	—
	4	—	—
	5	The cooling solenoid valve is open.	The cooling solenoid valve is closed.
	6	—	—
	7	The exhaust fan is rotating.	The exhaust fan is stopped.

13.8.8 Independent Load Drive

This function is used to drive the loads on an individual basis.

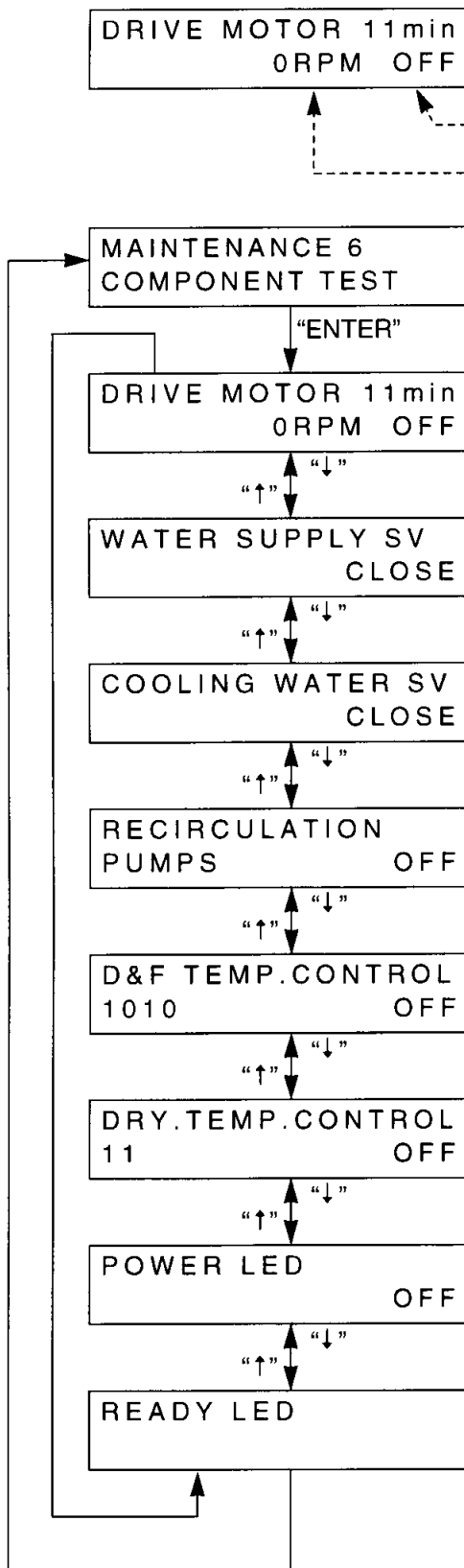

- The processing speed setting is displayed on the right-hand side of the upper line.
- The rotating speed is displayed from middle to right-hand side of lower line of the lower line (average of 10 sampled data).

- The developer heater, fixer heater, circulation pump, and cooling solenoid valve operating status is displayed on the left-hand side of the lower line.
- The dryer 1~3 heater, and dryer fan operating status is displayed on the left-hand side of the lower line.

13.8.9 Temperature Calibration

This function provides developer, fixer and drying zone calibrations.

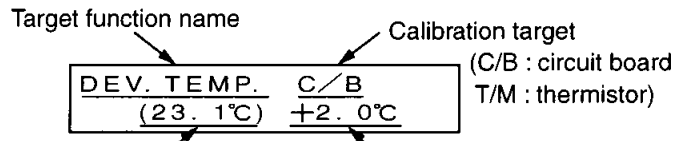

Indicates the sum of measured temperature, circuit board calibration value, and thermistor calibration value
 Measured temperature + circuit board calibration value + thermistor calibration value = control temperature

Shows the calibration Value
 (a blinking Value can be edited with the "↑"/"↓" key)

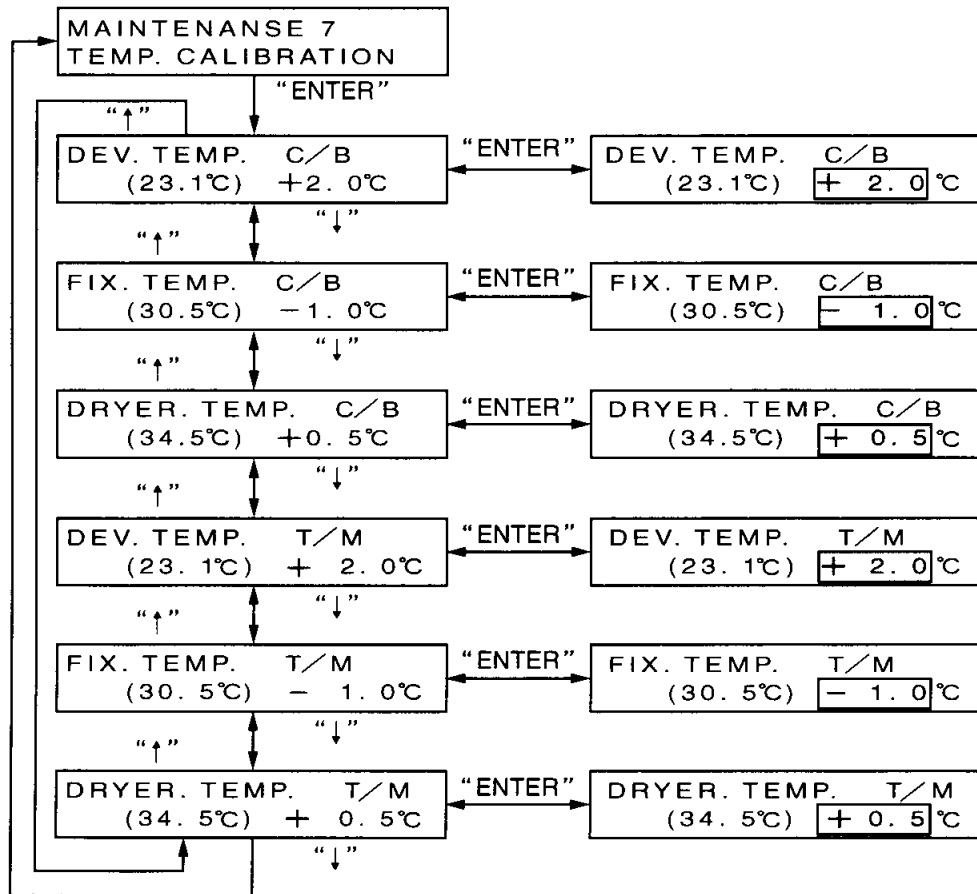

13.8.10 Replenishment Pump Calibration

This function provides replenishment pump calibrations.

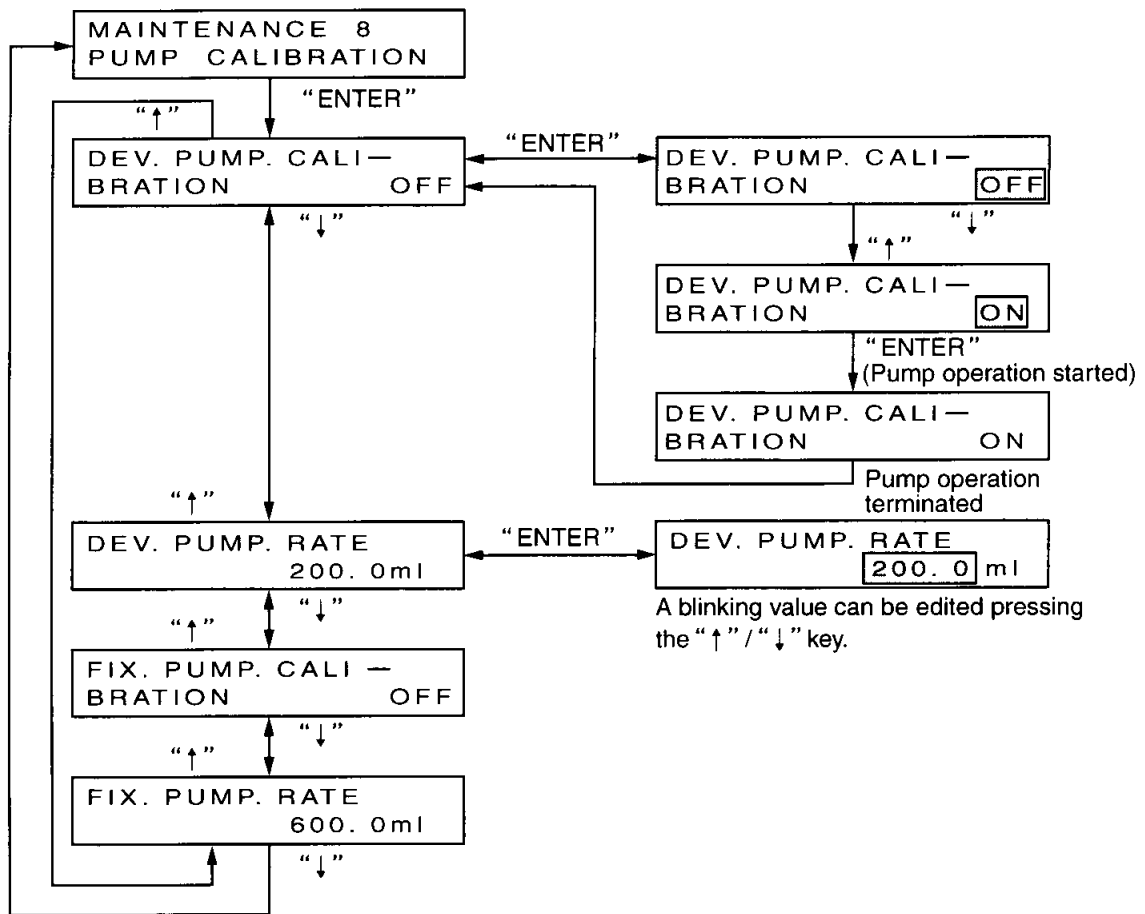

※ The pump operation terminates upon completion of one unit of replenishment.
 (Status switching from ON to OFF cannot be effected)

13.8.10.1 Calibration Procedure

(Although the developer replenishment pump is cited as an example below, the same procedure applies to the developer and fixer replenishment pumps.)

- (1) With a graduated cylinder, measure the amounts of five cycles of replenishment.
(Repeat the following step five times.)

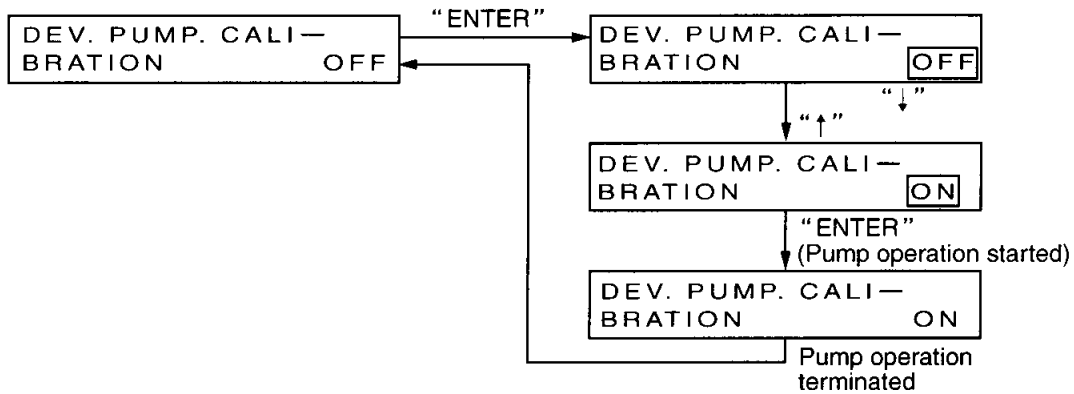

- (2) Average the five replenishment amount measurements made in step (1), enter the obtained average value as the DEV. PUMP RATE.

(Example) When the average of five replenishment cycles is 192.0 ml

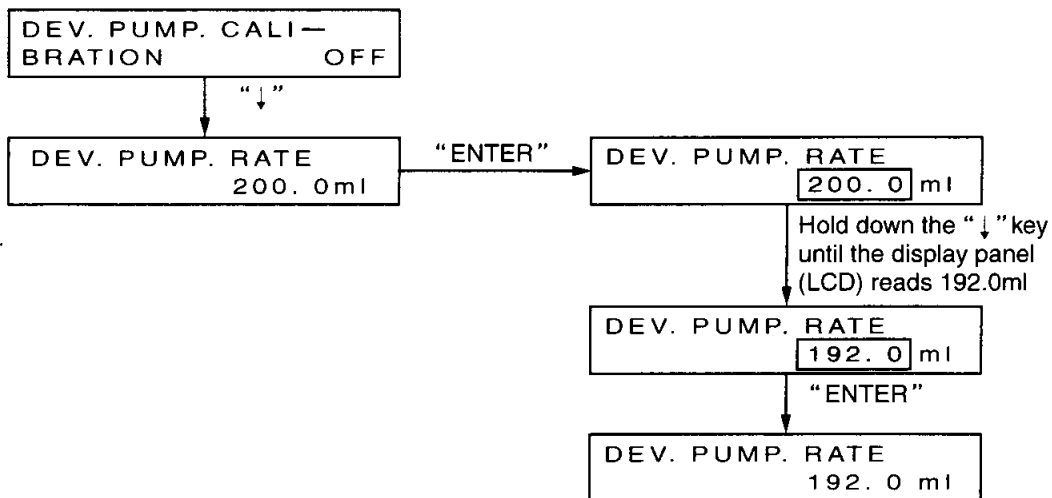

13.8.11 Display Panel (LCD) Backlight Setup

This function is used to change the display panel (LCD) backlight ON/OFF conditions.



display panel (LCD) backlight condition setup

ON : Normal

OFF : The LCD backlight does not turn ON.

(Even when OFF is chosen here, the display panel (LCD) backlight turns ON at the press of the LIGHT key.)

* The display panel (LCD) backlight does not turn ON even at the time of mode switching or error occurrence.

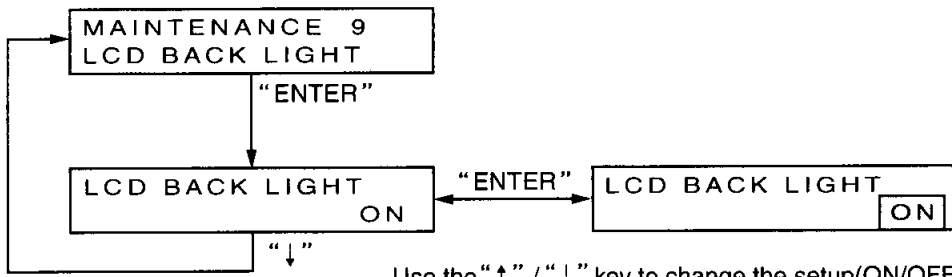

Use the "↑" / "↓" key to change the setup(ON/OFF)

13.8.12 Operating Time Display/Clear

This function is used to display the cumulative operating time or enter relevant data.

Displayed information

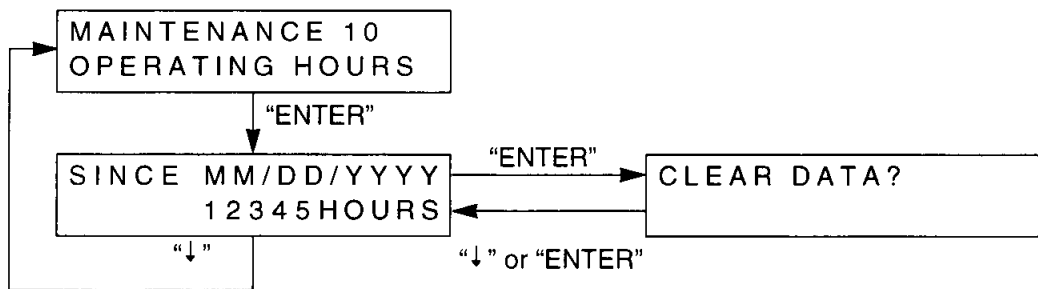
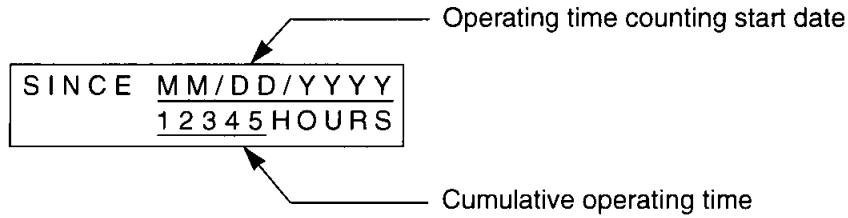

“↓” Does not clear data.
 “ENTER” Clears data (so that the following screen indication results).

Current date

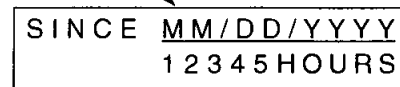

- * When the cumulative operating time exceeds a maximum of 99999 hours, the displayed value resets itself back to 0 (zero).
- * The date displayed upon memory clearing is “- - / - - / - - - - .”
- * Cumulative operating time fractions not smaller than 30 minutes are counted as one hour.
 (Example: If the cumulative operating time is 30 minutes, the display panel (LCD) reads 1 h.)
- * When the ENTER key is pressed from the “CLEAR DATA?” screen, the system clears the cumulative operating time and selects the current date as the operating time counting start date.
- * The cumulative operating time is counted during the following processes.
 1. Standby process
 2. Film processing
 3. Selftest bypass processing
 4. Preheat process

14. Troubleshooting Guide

14.1 Temperature Compensation Values for Circuit Board Replacement

Two temperature compensation values are provided: circuit board compensation value and thermistor compensation value. When the NMC circuit board is replaced, its temperature compensation can be made by entering a compensation value that is indicated in the compensation value table attached to the rear of the dryer cover. You do not have to measure the temperature for this purpose. After the thermistor is replaced, however, measure the temperature and then enter an appropriate compensation value.

14.2 If the Developer Heater Does Not Operate

The NFB3 in the control box is tripped or bi-metal switch FIX is activated.

In either case, check for a risk of smoke generation, combustion, or electric shock, and then reset the tripped NFB or activated bi-metal switch.

14.3 If the Fixer Heater Does Not Operate

The NFB5 in the control box is tripped or bi-metal switch DEV is activated.

In either case, check for a risk of smoke generation, combustion, or electric shock, and then reset the tripped NFB or activated bi-metal switch.

14.4 If the Dryer Heater Does Not Operate

The NFB1, NFB2, or NFB4 in the control box is tripped or bi-metal switch DRY1, DRY2, or DRY3 is activated.

In any case, check for a risk of smoke generation, combustion, or electric shock, and then reset the tripped NFB or activated bi-metal switch.

14.5 If the Lower or Upper Electrical System Section Cooling Fan Does Not Operate

Check whether fuse F12 on the MUD circuit board is blown.

14.6 If the Replenishment Pump, Solenoid Valve, or Exhaust Fan Does Not Operate

Check whether fuse F11 on the MUD circuit board is blown.

14.7 If the Circulation Pump Does Not Operate

The NFB6 is tripped.

14.8 If the Power Does Not Turn On (the Display Panel Remains Inoperative)

If the thermal fuse in the transformer is blown, replace the transformer.

If fuse F1 or F4 is blown, replace it.

If the 5 V power supply is defective, replace it.

If the MUD (CN5)-NMC (CN2) cable is broken, replace it.

If the NMC circuit board is defective, replace it.

If the NMC circuit board is defective, replace it.

If the LCD is defective, replace it.

15. Circuit Diagram-1

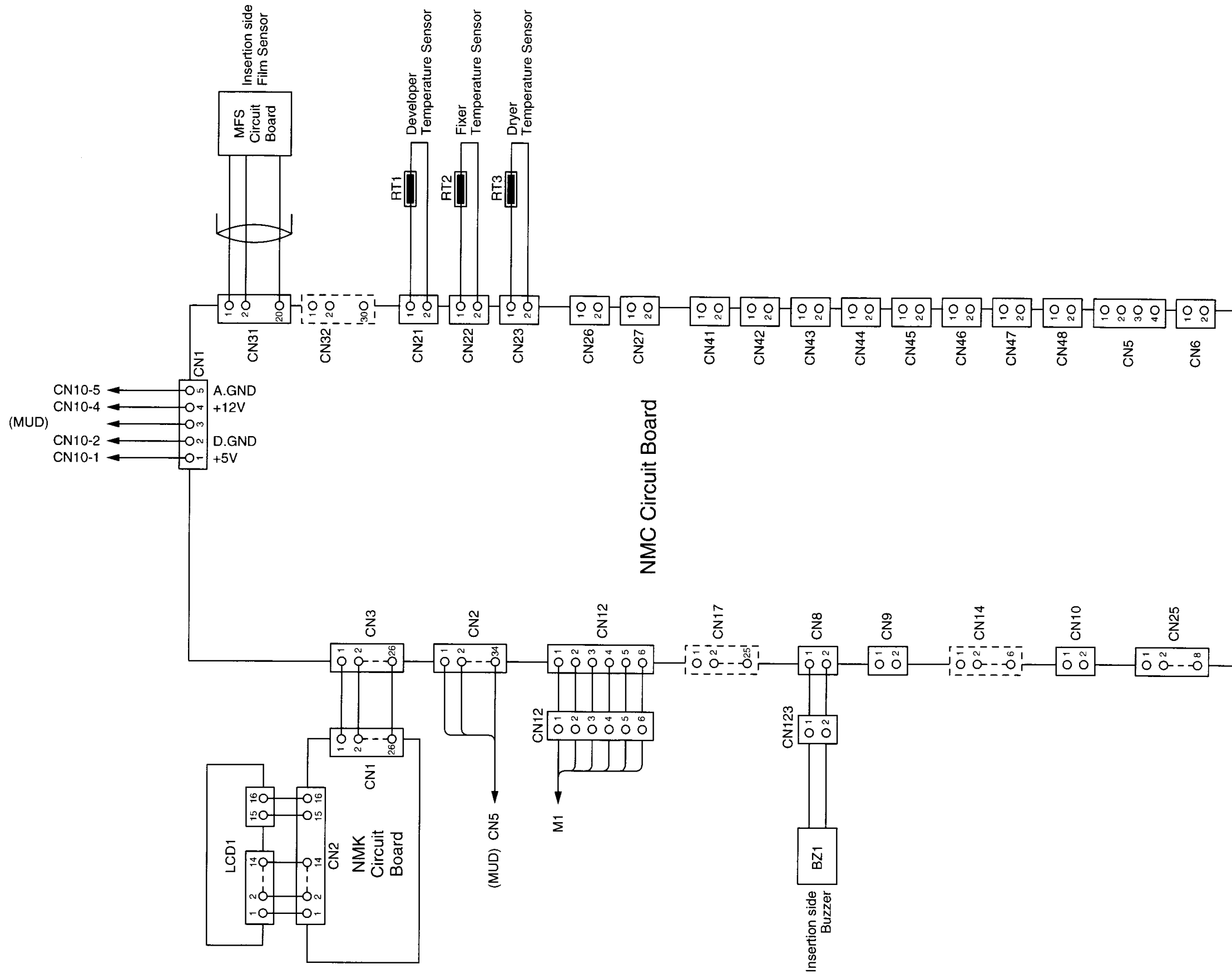

16. Circuit Diagram-2

<FIP7000>

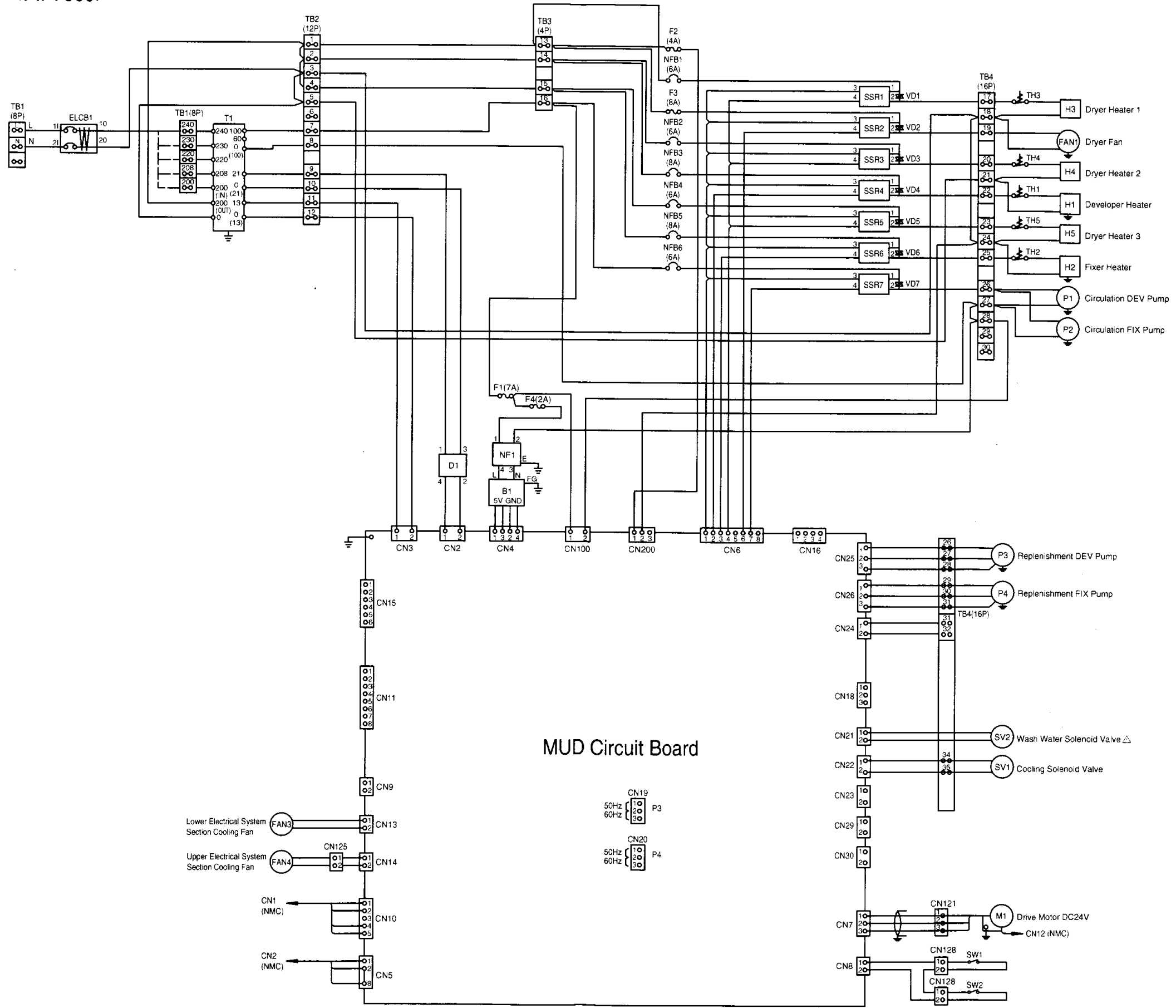

MUD Circuit Board

17. Main Body Parts Arrangement Diagram

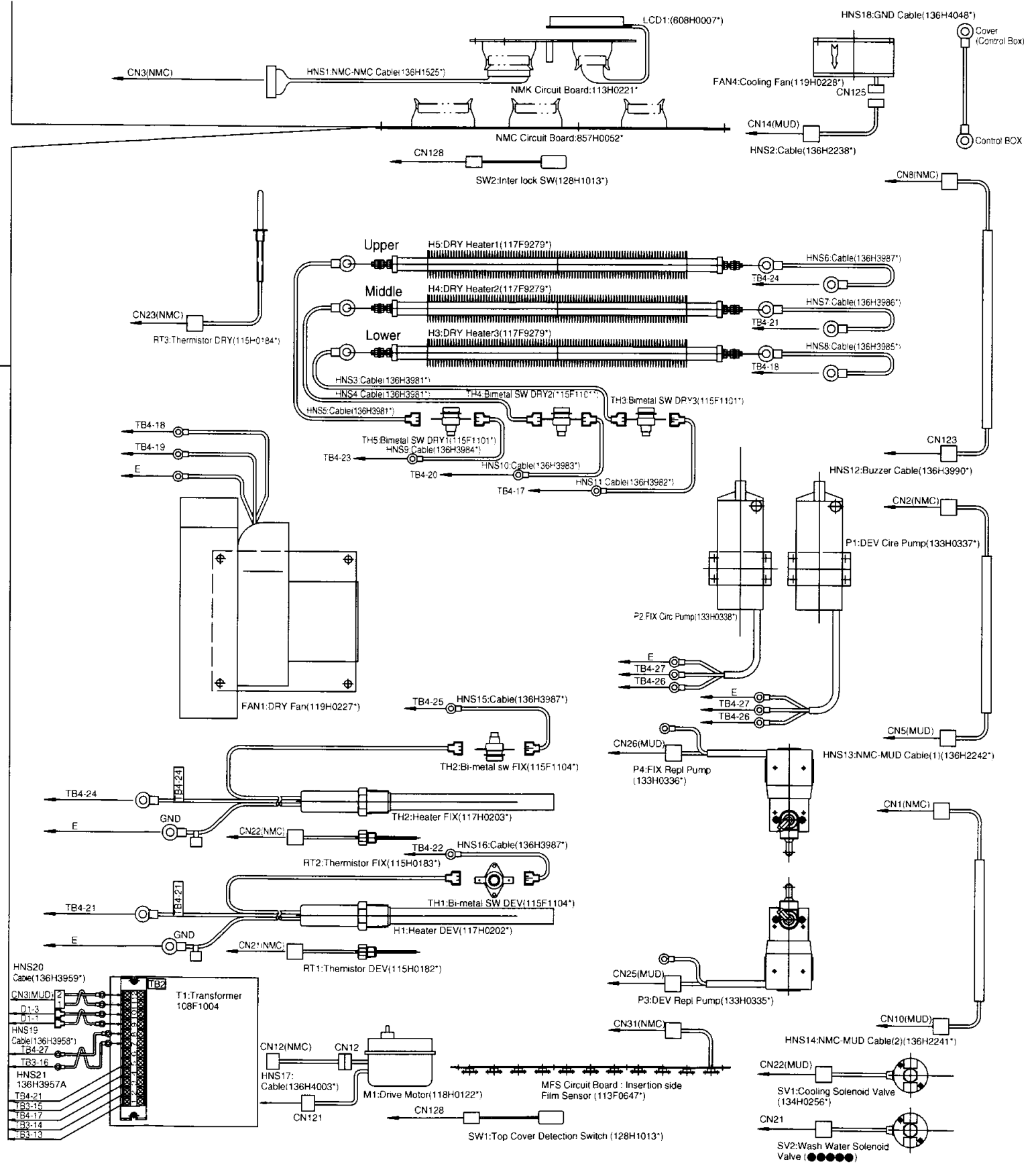
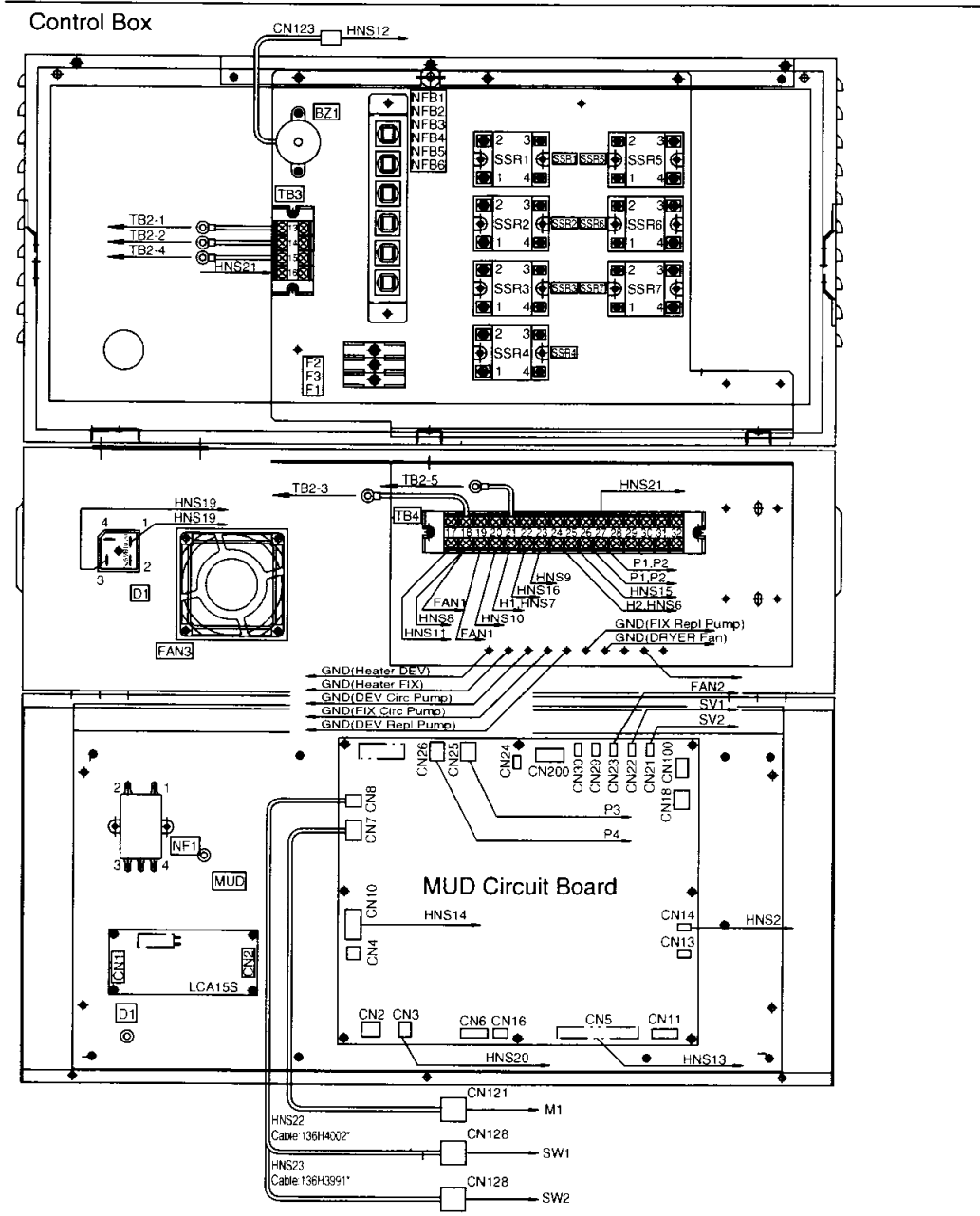
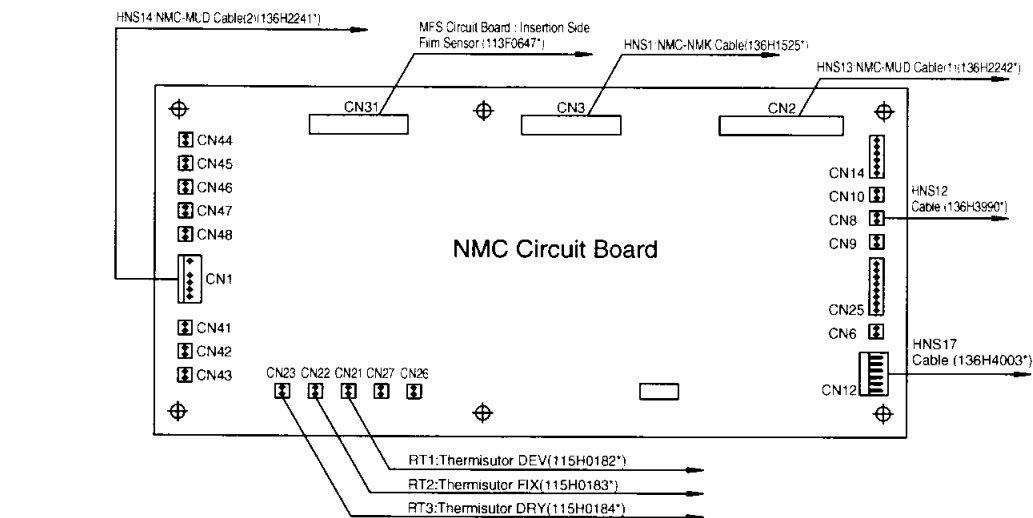



FUJIFILM

FUJI PHOTO FILM CO., LTD.

26-30, Nishiazabu 2-chome, Minato-ku, Tokyo 106-8620, Japan
